

Kirami FinVision® -outdoor shower XL Misty

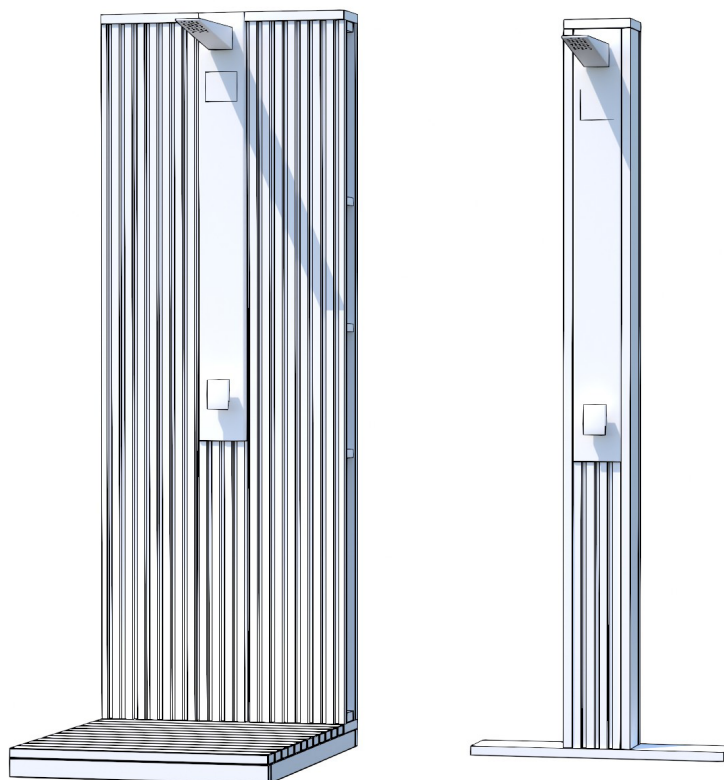

Instructions for installation



FI

SV

EN

DE

FR

NL

IT

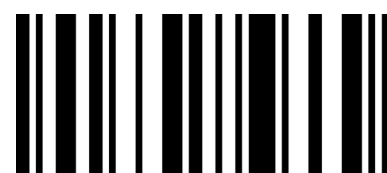

3927

Contents

page 3	FI	KÄYTTÖOHJEET
page 17	SE	BRUKSANVISNING
page 31	EN	INSTRUCTIONS FOR USE
page 45	DE	GEBRAUCHSANWEISUNGEN
page 59	FR	MODE D'EMPLOI
page 73	NL	GEbruIKSAANWIJZINGEN
PAGE 87	IT	MANUALE UTENTE



Like us on Facebook! Tips on using the product, competitions, experiences, images, etc. at

www.facebook.com/kiramioy



Follow us on Instagram

<https://www.instagram.com/kiramioy>



Kirami Oy YouTube channel

<https://www.youtube.com/c/KiramiOy>

Kirami FinVision® -outdoor shower XL Misty



Käyttöohje

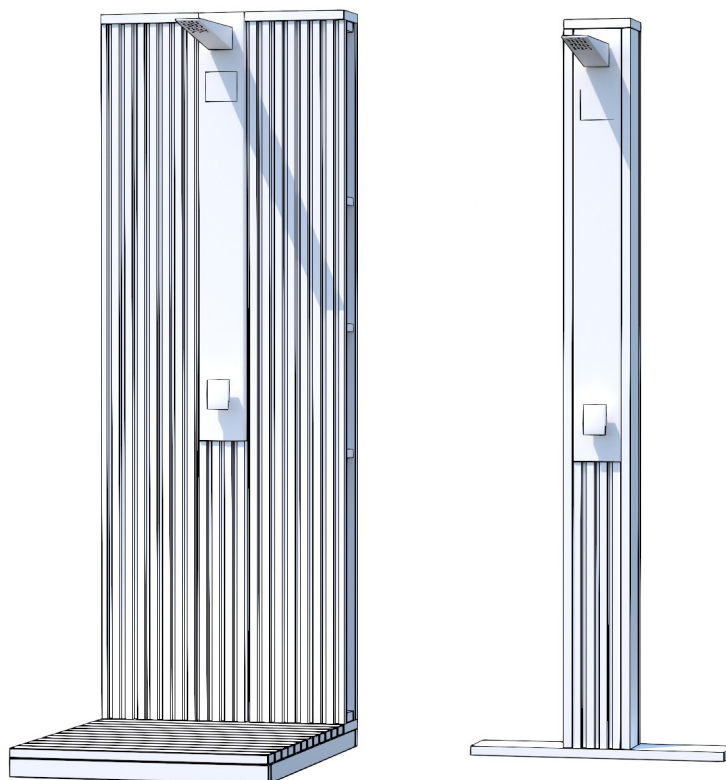

Tarkasta toimituksen sisältö viipymättä!
Tutustu huolella ja säilytä ohjeet tulevaisuutta varten.

YLEISTÄ

Jos tilaat suihkun terassin yhteydessä, on ulkosuihkumoduuli valmiiksi kiinnitettynä terassiin. Suihkuseinän voi asentaa myös jälkikäteen, jolloin se toimitetaan osissa.

Suihkulle on esivedettynä liitännät, jotka voi liittää halutessaan niin kylmän kuin kuuman veden putkistoon tai vaihtoehtoisesti puutarhaletkuun.

Alustalla varustellun suihkun lattiaritilä on irrotettava. Ritilän alla on sinkitystä pellistä valmistettu kaukalo, joka ohjaa pesuveden viemäriputkelle.

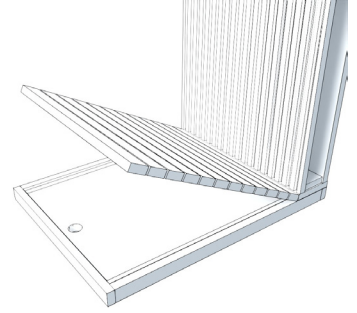

TOIMITUKSEN TARKISTUS

Suosittellemme aina tarkistamaan ennen rahtikirjan kuittaamista, että olet saanut ehjän pakkauksen. Jos huomaat myöhemmin sisällöstä puuttuvan jotain, ota yhteyttä toimitajaan.











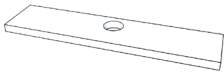

Jos tilasit ulkosuihkun samaan aikaan muiden moduulien kanssa niin voit siirtyä kohtiin ” TULOVEDEN KYTKENTÄ” ja ” VEDENPOISTON LIITÄNTÄ”.

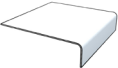
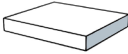

HUOM! Talveksi ulkosuihku on tyhjennettävä vedestä pakkasvaurioiden välttämiseksi.

Avaa hana ja puhalla paineilmaa järjestelmän läpi.

OSALUETTELO

Nro	Kuva	Nimi	Pilari (Ilman alustaa)	Pilari (Alustalla)	Suihkuseinä (Terassimalli)	Suihkuseinä (Ulkomalli)
1.		Alusta			1	1
2.		Pilarin alalauta	1	1		
3.		Suihkuseinä			1	1
4.		Pilari	1	1		
5.		Suihkupää (sis. aluslevy ja mutteri)	1	1	1	1
6.		Vedenpoistoputki		1	1	1
7.		Liitospelti kattoon			1	
8.		Hylly			6	6
9.		Suoja - Pilari	1	1		
10.		Suojapelti				1
11.		Ruuvi 5x35 mm			8	
12.		Ruuvi 4,2 x 19 mm		10	10	10
13.		Ruuvi 4,8x25				4
14.		Ruuvi 4,8 x 75 mm	12	12	4	6

ASETTELU

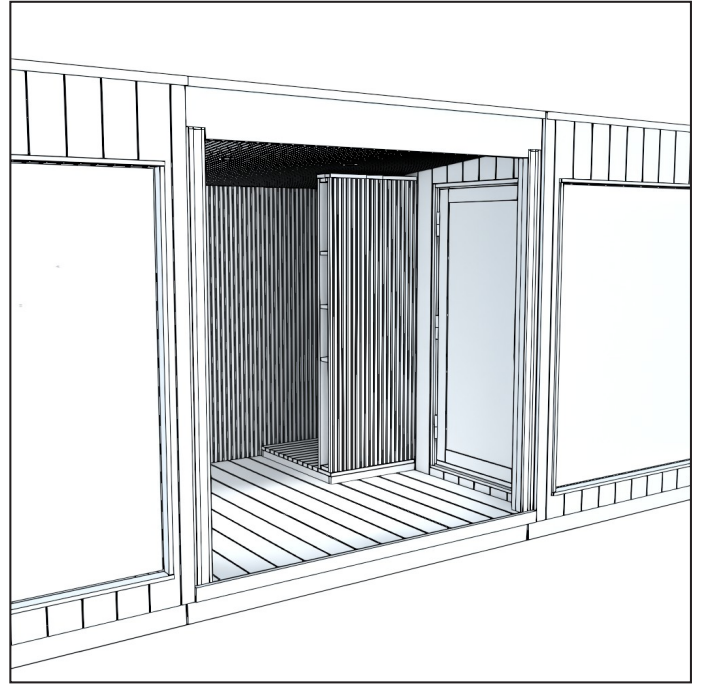
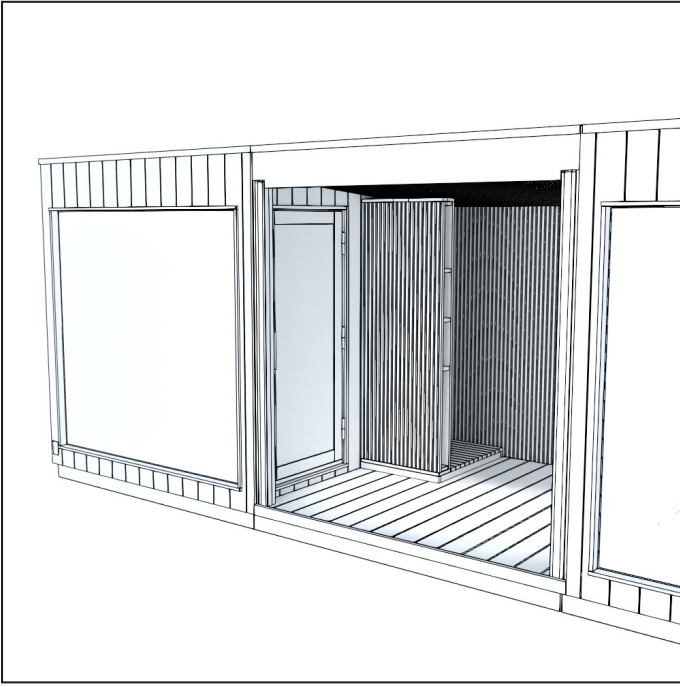

Kirami FinVision® -ulkosuihku Misty (terassimalli) asennetaan aina Kirami FinVision® -terassin sisään aina joko vasempaan tai oikeaan reunaan siten että ulkosuihkun toinen kylki on toista moduulia vasten.

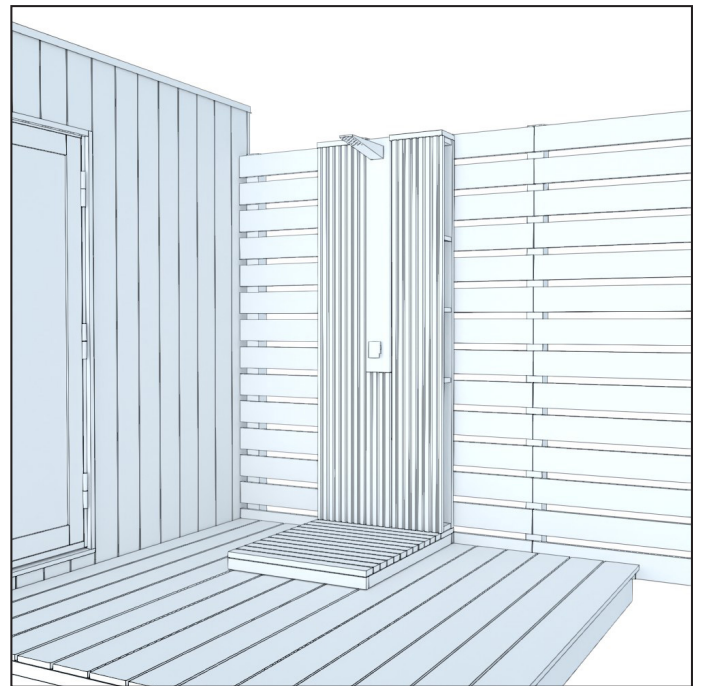
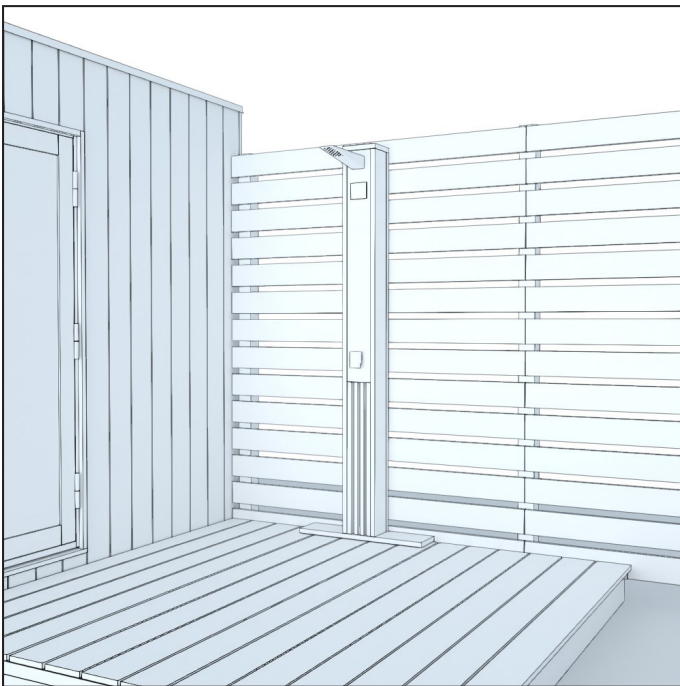

Kirami FinVision® -ulkosuihku (ulkomalli) ja Pilari-mallit voi asentaa mihin vain tasaiselle alustalle, esimerkiksi ulko- tai kattoterassille, paljun, uima-altaan tai saunan yhteyteen.

Ulkosuihkut on aina suositeltavaa asentaa seinää tai muuta tukevaa rakennetta vasten.

ALUSTAN KIINNTYS

Pilari

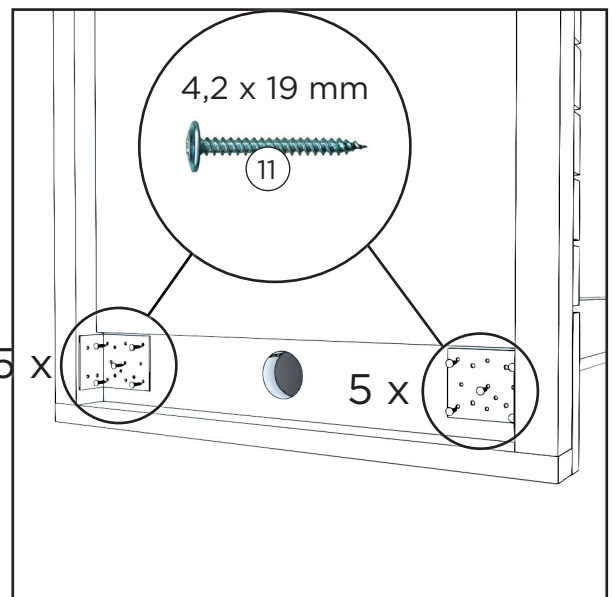
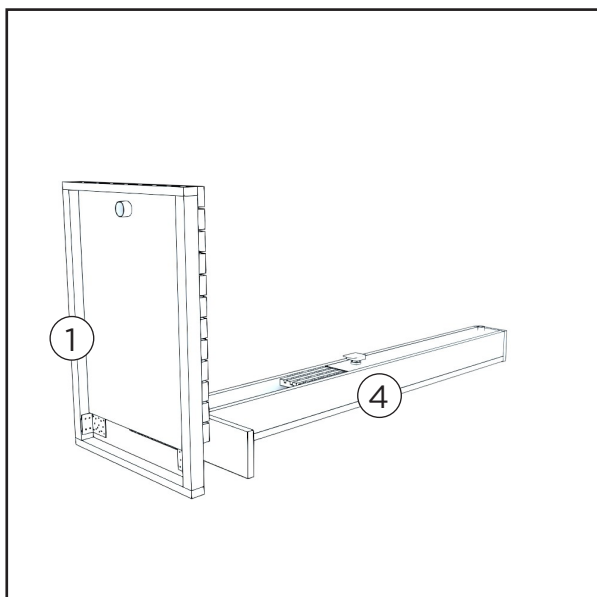
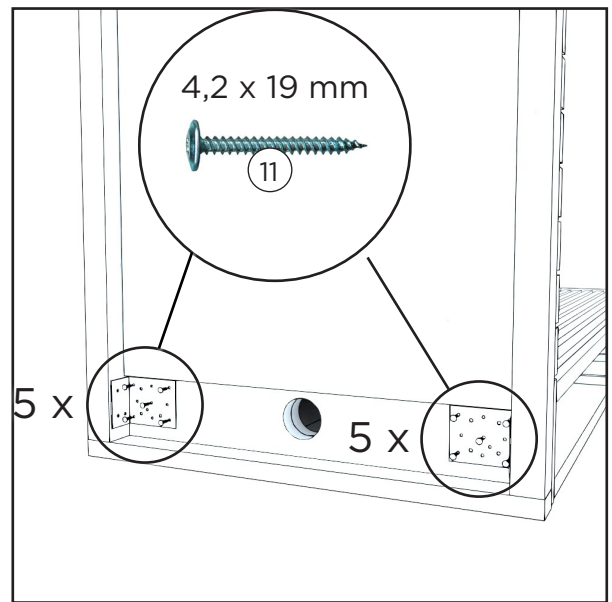
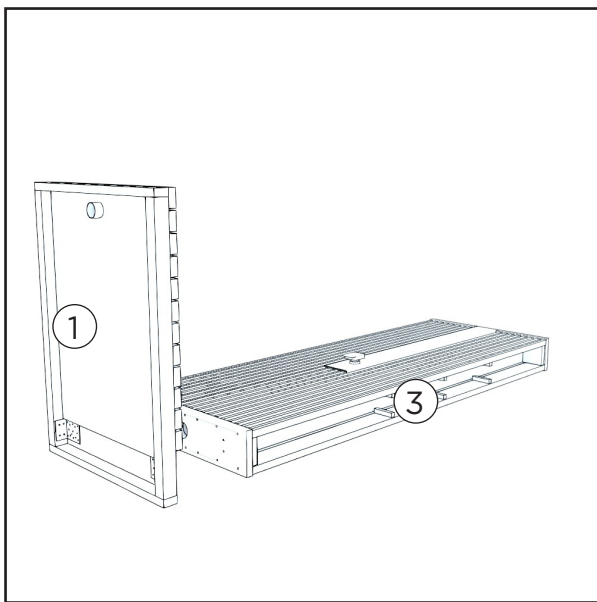
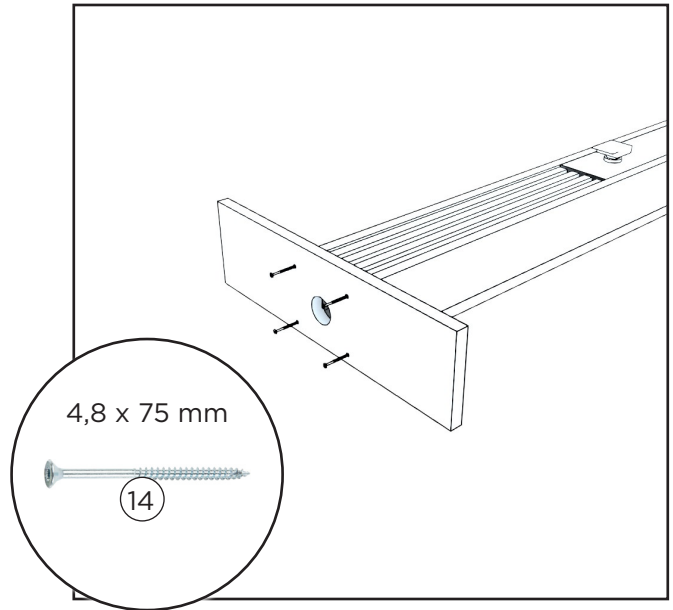
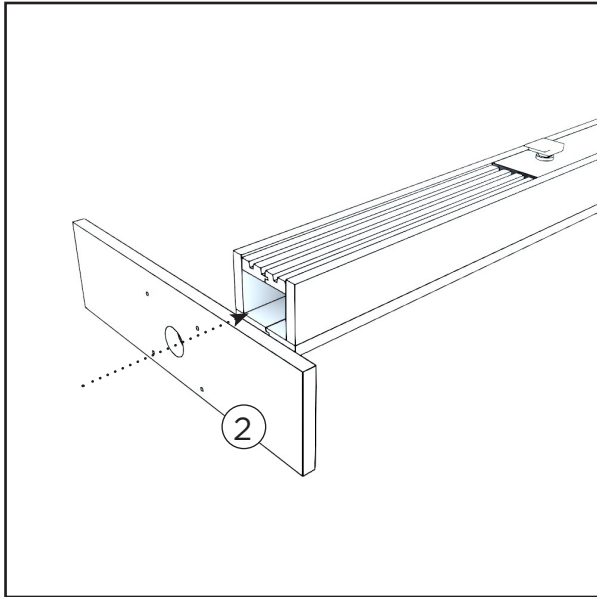

SUIHKUPÄÄN KIINNITTÄMINEN

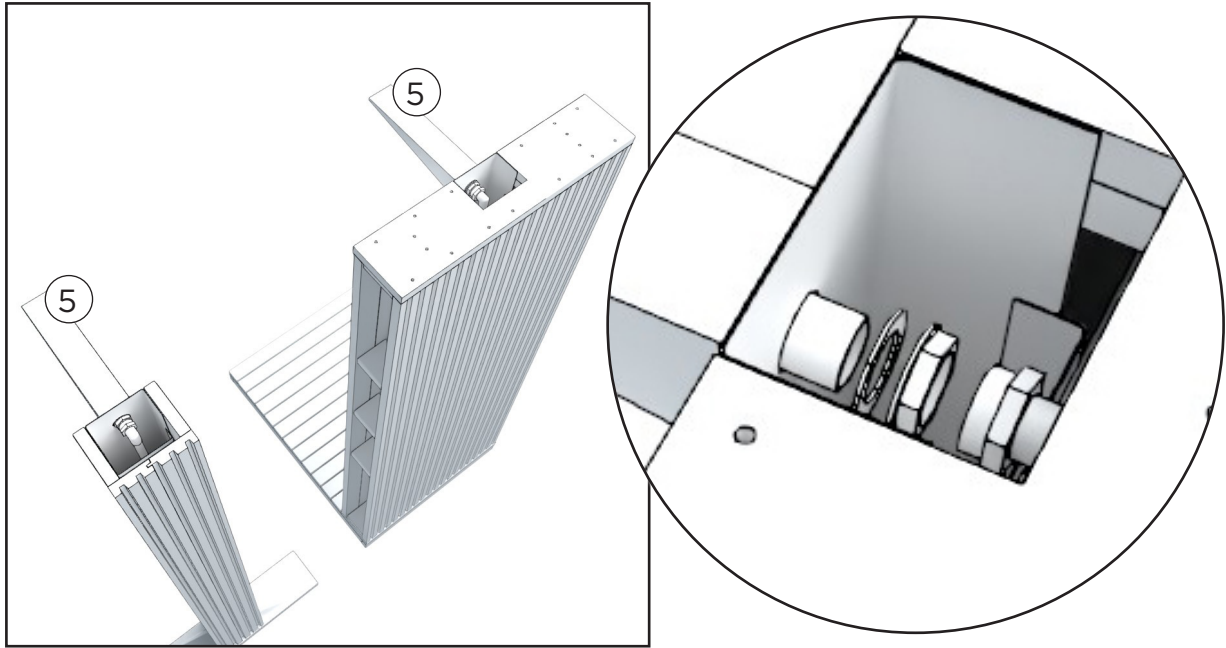

Liitä suihkupää ensin ruostumattomasta teräksestä valmistettuun levyyn messinkimutterilla, huomaa että ruostumattoman levyn ja messinkimutterin väliin tulee aluslevy. Poista teippi suihkun sisällä olevan kulmasta ja liitä se suihkupäähän.

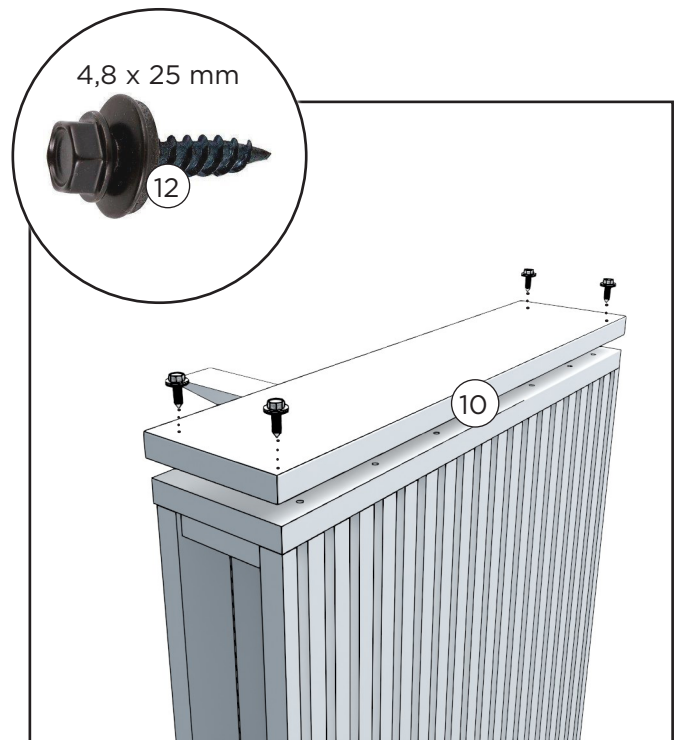

Pilarimalli: Liitä pääty ulkosuihkuun neljällä ruuvilla.

Ulkosuihku (ulkomalli): Liitä suojaipelti ulkosuihkuun päätyyn neljällä ruuvilla.

Huom. Terrassimallin suihkuun ei liitetä suojaa.

TERASSIMALLIN KIINNITTÄMINEN

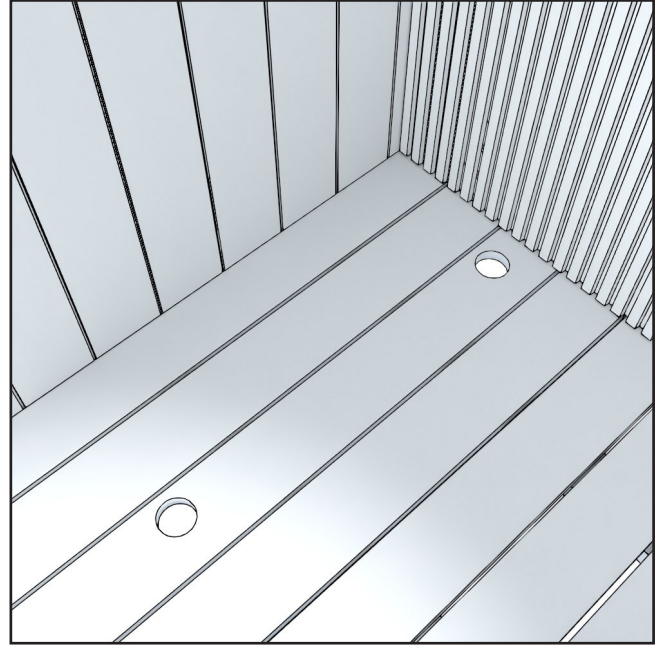
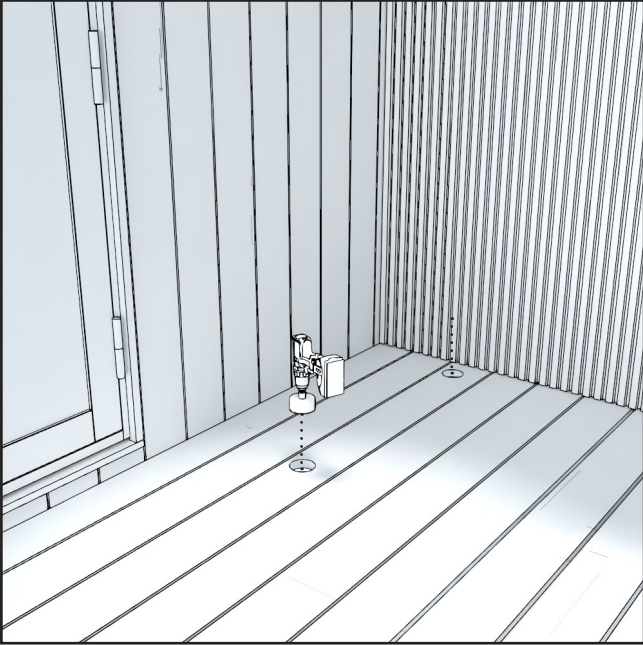

Kun Kirami FinVision® -ulkosuihku Misty tilataan jälkikäteen, täytyy terassimoduuliin porata reiät veden tulo- ja poistovedelle. Terassiin porattavan reiän halkaisija on vähintään 73 mm.

Mitat oikealle puolelle asennettaessa:

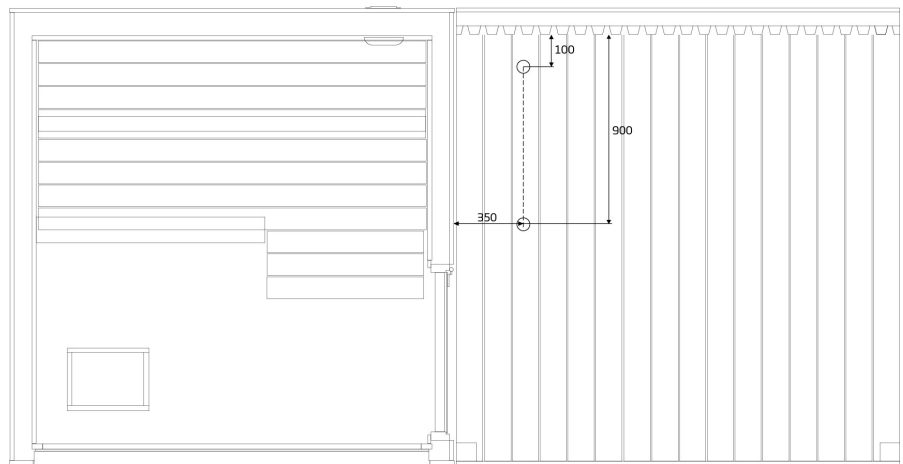

Mitat vasemmalle puolelle asennettaessa:

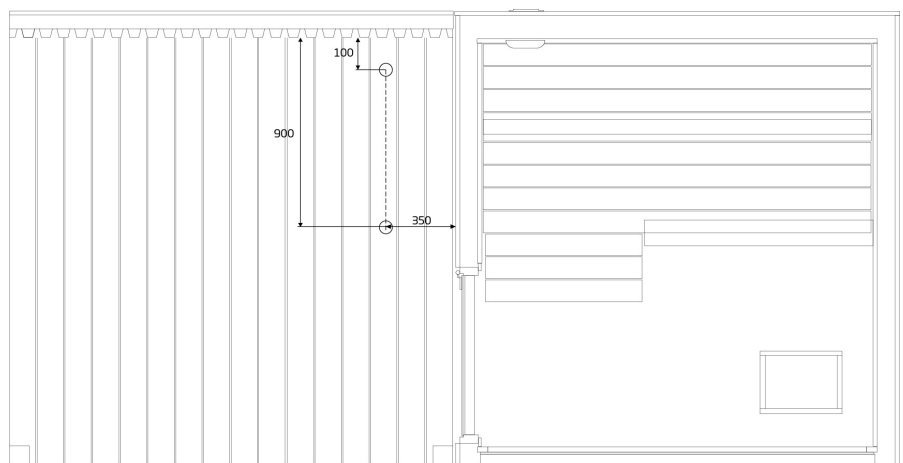

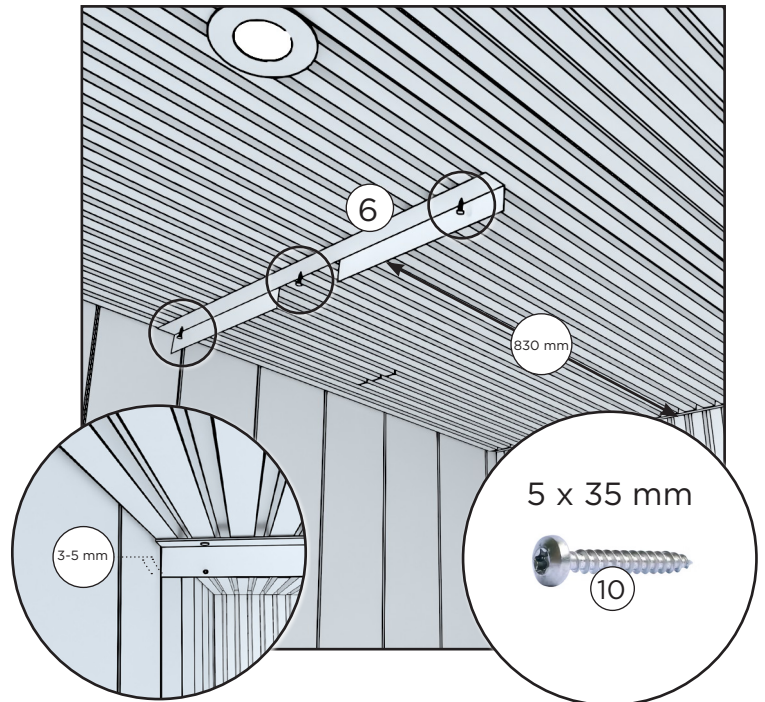
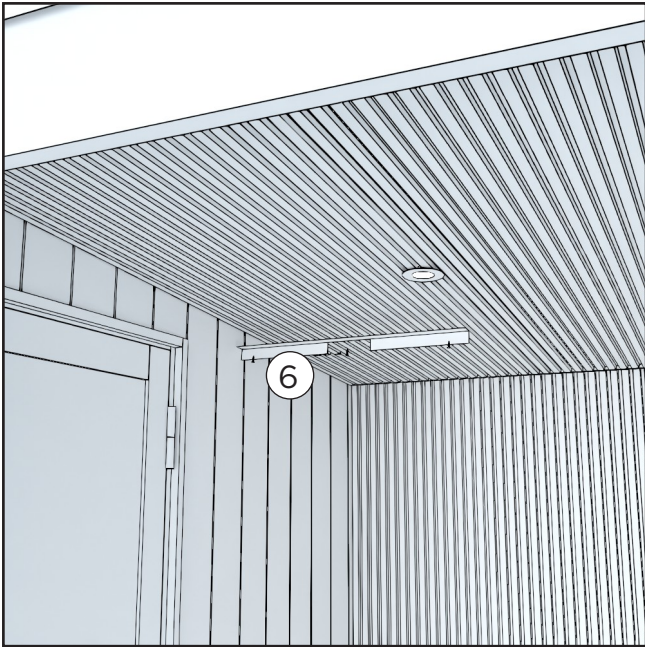

Kiinnitä ulkosuihkun ja katon liitospelti terassin sisäkattoon 830 mm päähän takaseinästä ja 3-5 mm päähän sivuseinästä

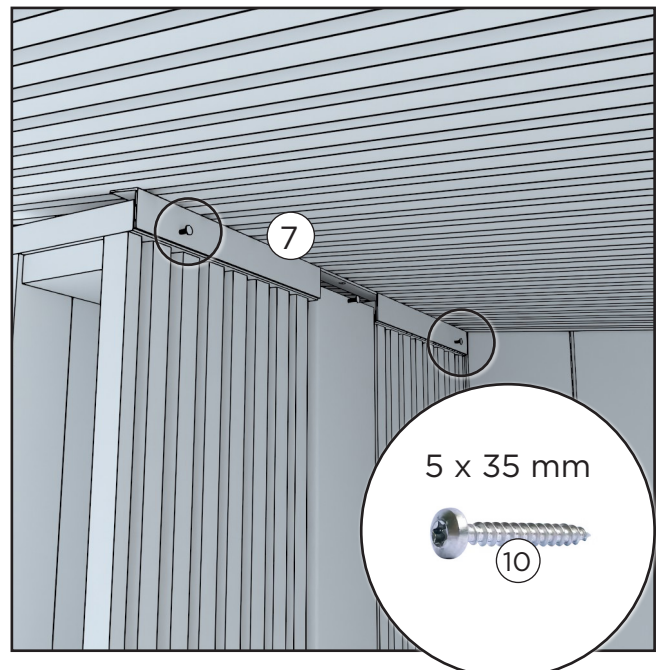
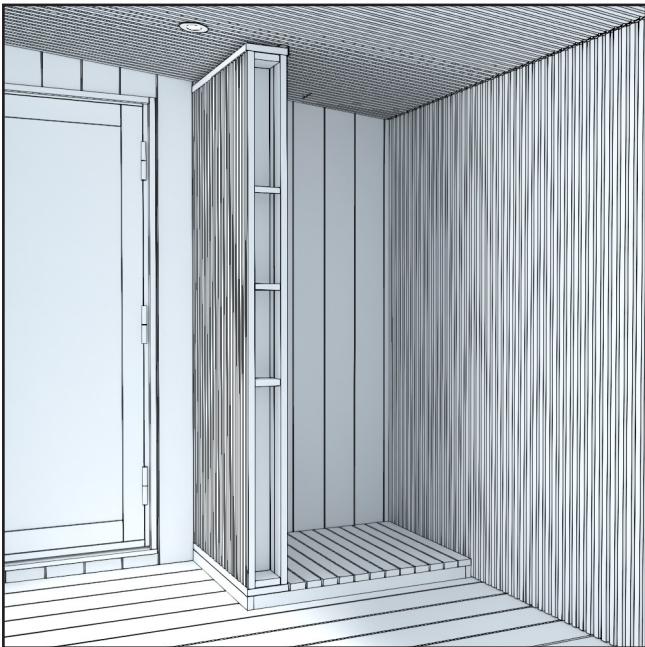

Asettele ulkosuihku päin liitospeltiä ja terassin takaseinää. Kiinnitä liitospelti ulkosuihkuun ruuveilla.

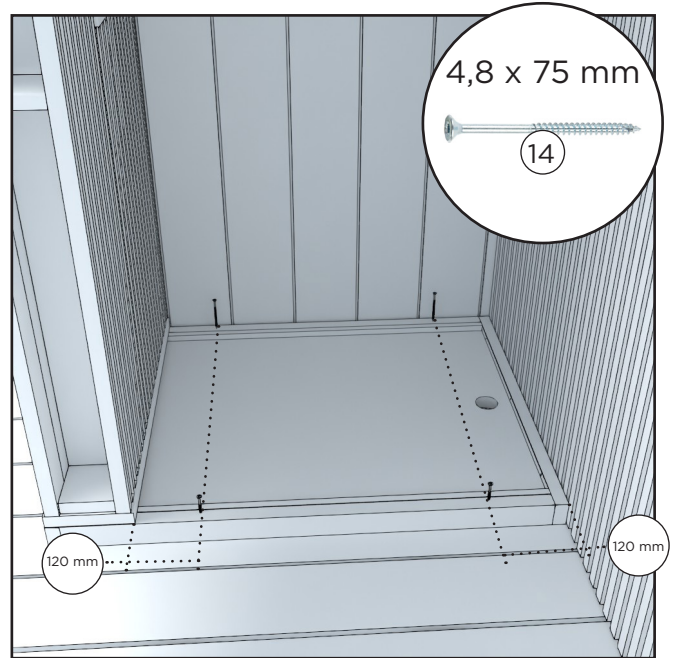
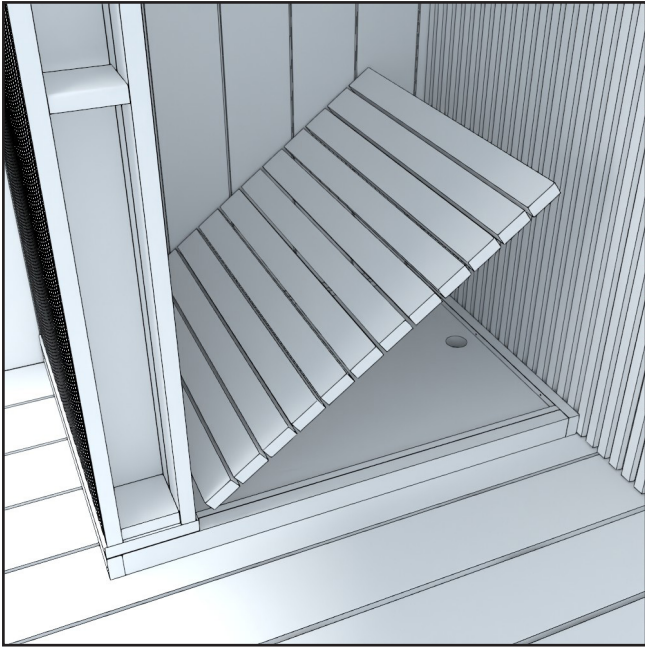

Nosta alustan ritilä pois ja kiinnitä ruuveilla alusta terassin kanteen. Lopuksi laita alustan ritilä takaisin paikoilleen.

MUIDEN MALLIEN KIINNITTÄMINEN

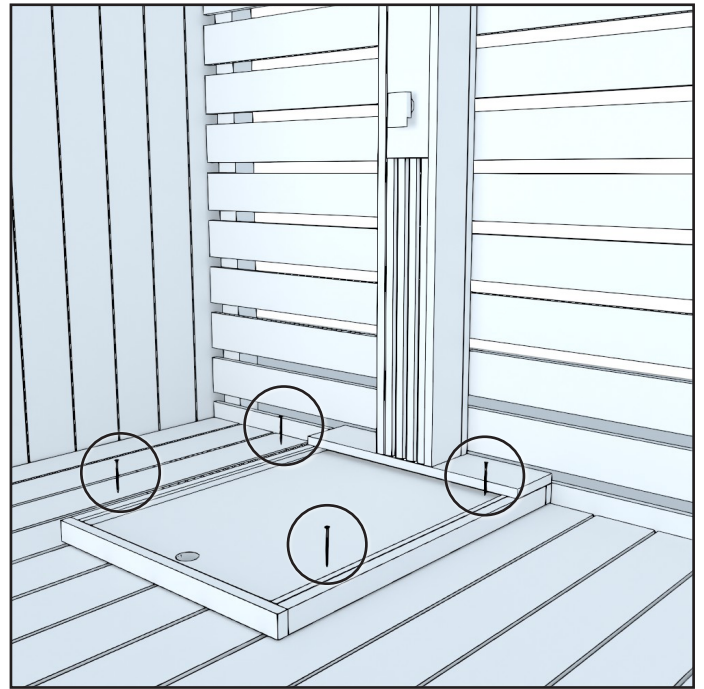
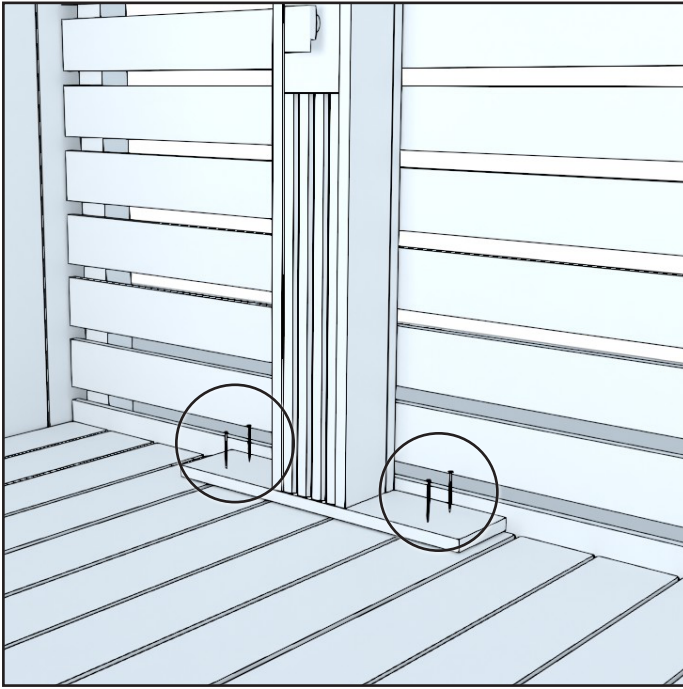

Pilarimallin ulkosuihkuissa, kiinnitä ulkosuihku alustasta alla olevaan materiaaliin neljällä ruuvilla.

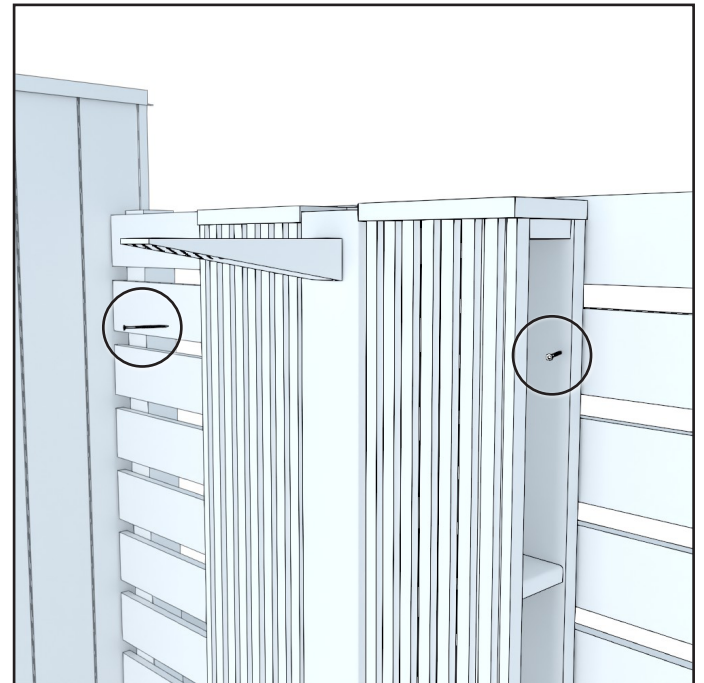
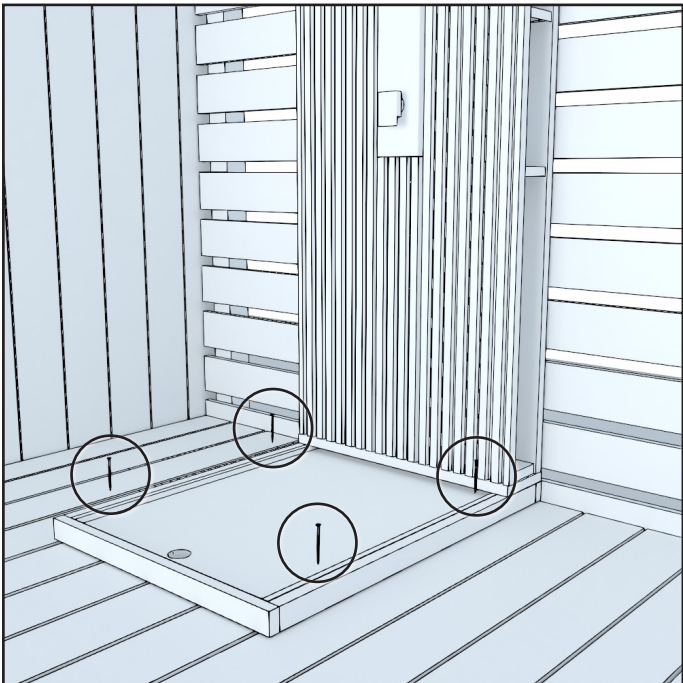

Seinällä varustellussa ulkosuihkussa, kiinnitä ensin alustasta alla olevaan materiaaliin neljällä ruuvilla. Kiinnitä seinän yläosasta vastakkaiseen materiaaliin molemmilta sivuilta kahdella ruuvilla.

TULOVEDEN KYTKENTÄ

Suihkulle on esivedettynä liitännät, jotka voi liittää halutessaan niin kylmän kuin kuuman veden putkistoon tai vaihtoehtoisesti puutarhaletkuun.

LIITÄNTÄ PUUTARHALETKULLA

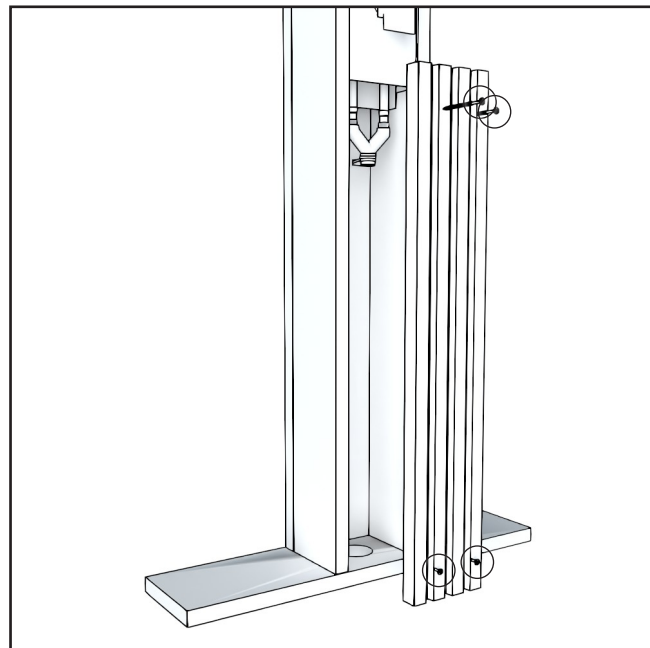
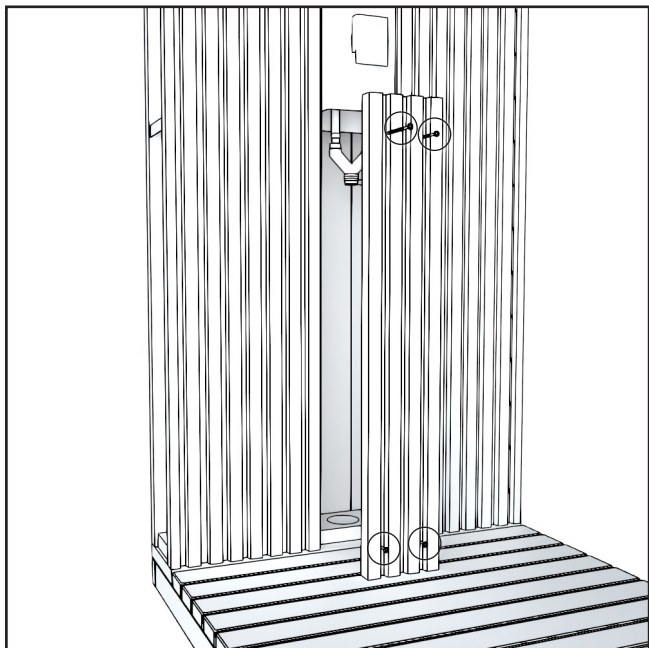

1. Tuloveden liittimet löytyvät etummaisten paneelien alta. Irroita paneelit.

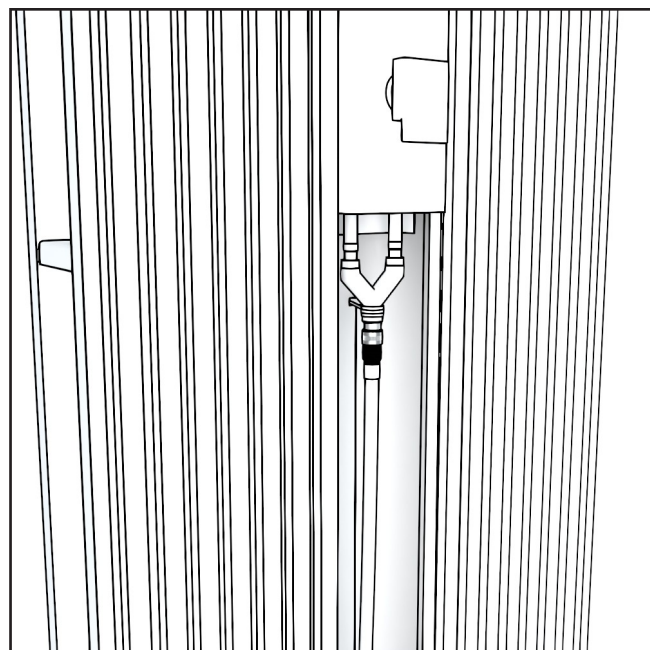

2. Pujota puutarhaletku ulkosuihkun alhaalla olevan reiän kautta seinän sisälle ja kytke suihkuun.

Kun letku on kytketty niin kiinnitä kaksi paneelia takaisin.

KUUMAN JA KYLMÄN VEDEN KYTKENTÄ

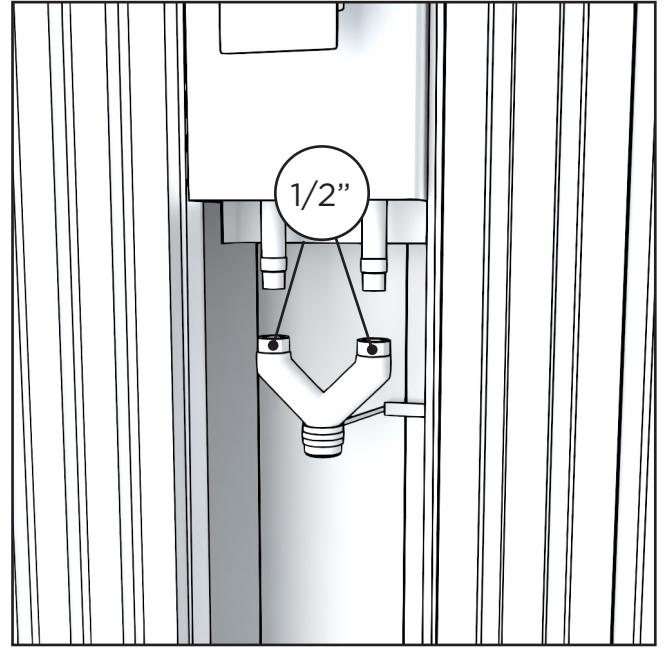
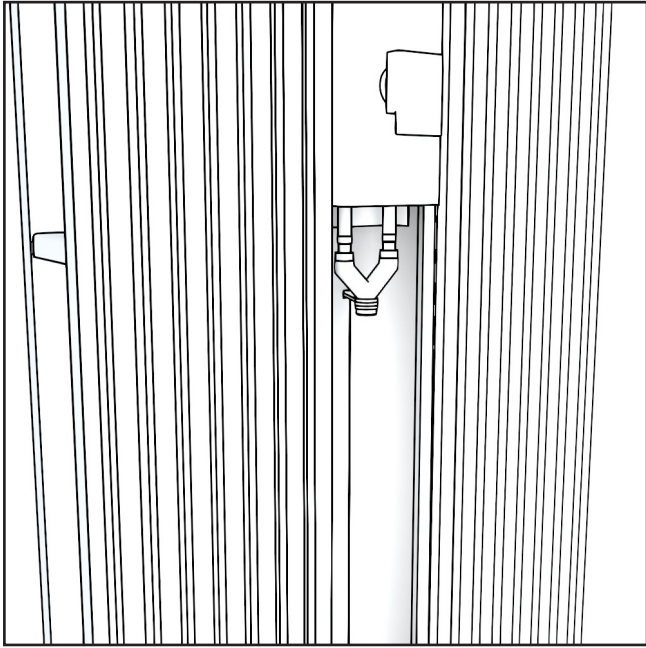

1. Irrota messinkinen haaroitin kiertämällä muttereita vastapäivään ja irrottamalla kiinnike suihkuseinästä.

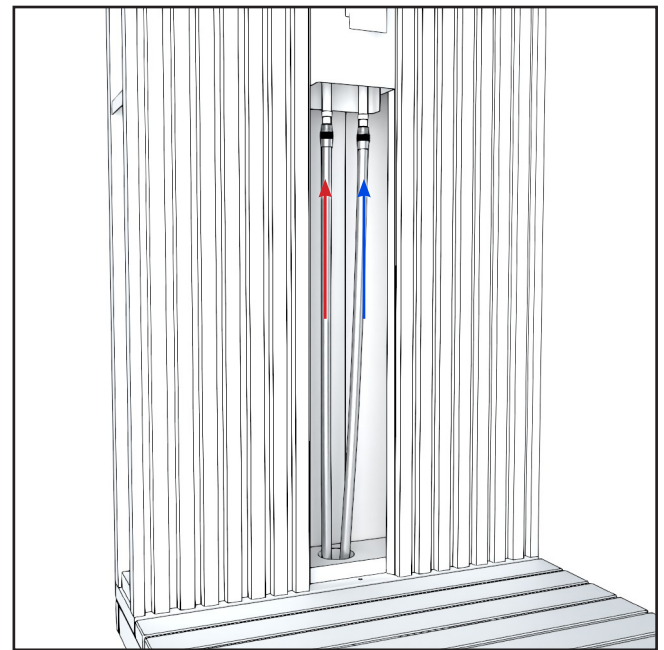
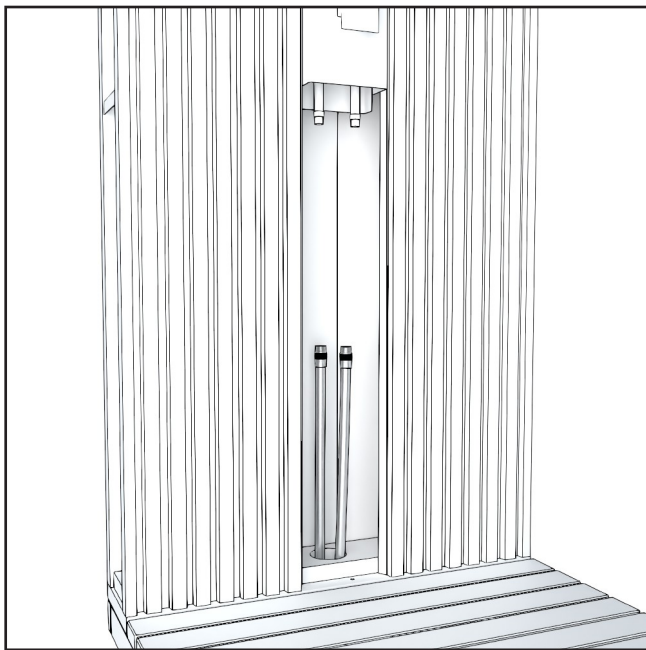

2. Pujota letkut/putket terassiin poraamasi reiän ja ulkosuihkun alhaalla olevan reiän kautta suihkuseinälle. Kytke lämmin vesi vasemmalle ja kylmä oikealle.

Kun letkut/putket on kytehty niin kiinnitä kaksi paneelia takaisin.

VEDENPOISTON LIITÄNTÄ

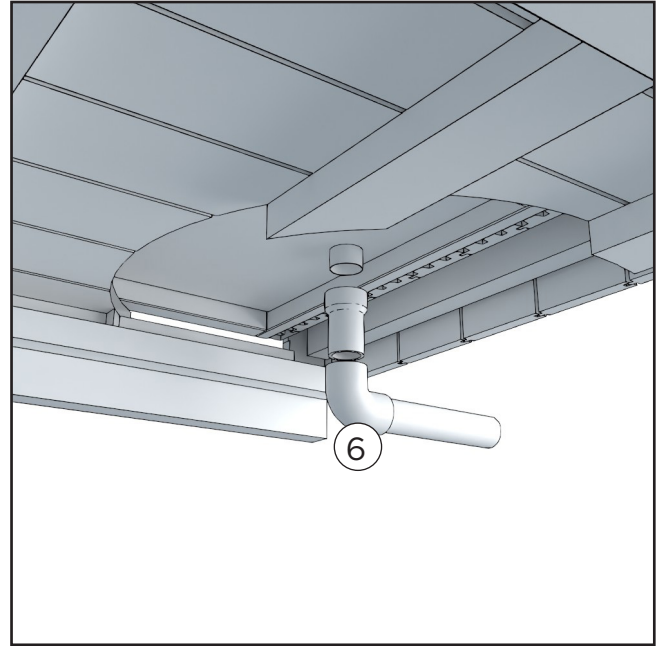
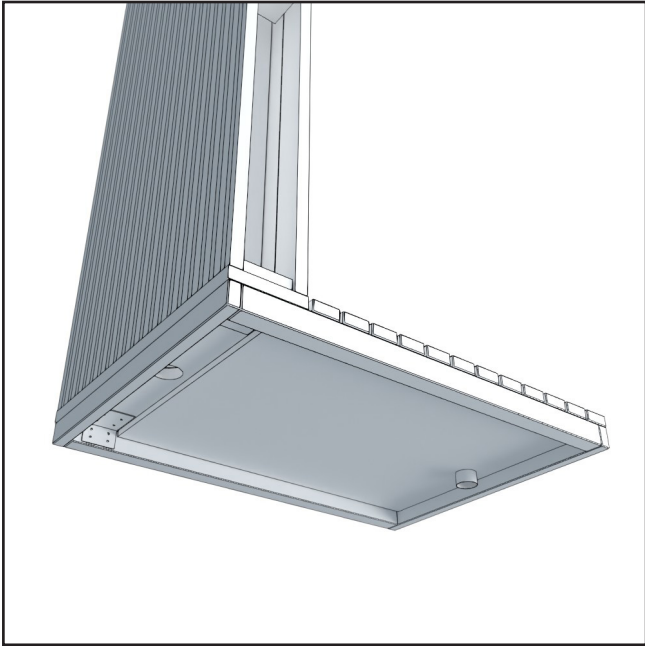

Alustassa on valmis 50 mm viemärilähtö pesuvesille. Kirami FinVision® -terassiin asennettaessa liitä putkiosat kuvan mukaisessa järjestyksessä jolloin saat ulkosuihkun vedenpoiston moduulin taakse.

HYLLYJEN ASETTELEMINEN

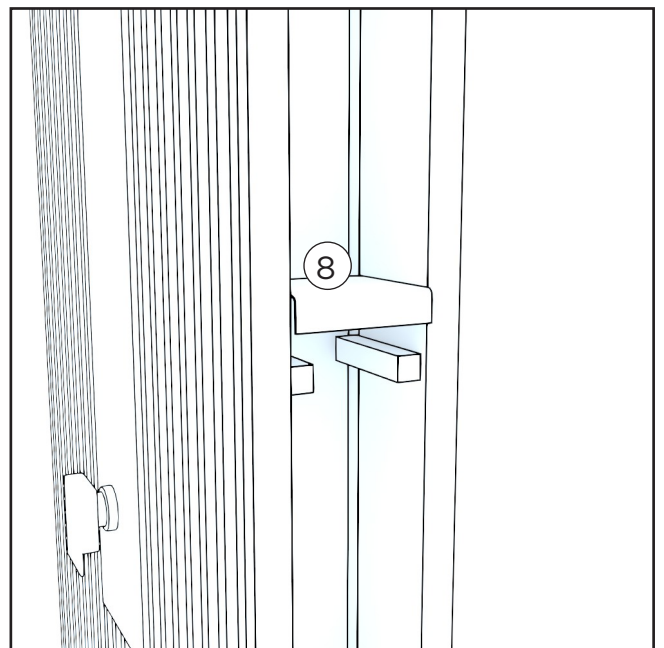
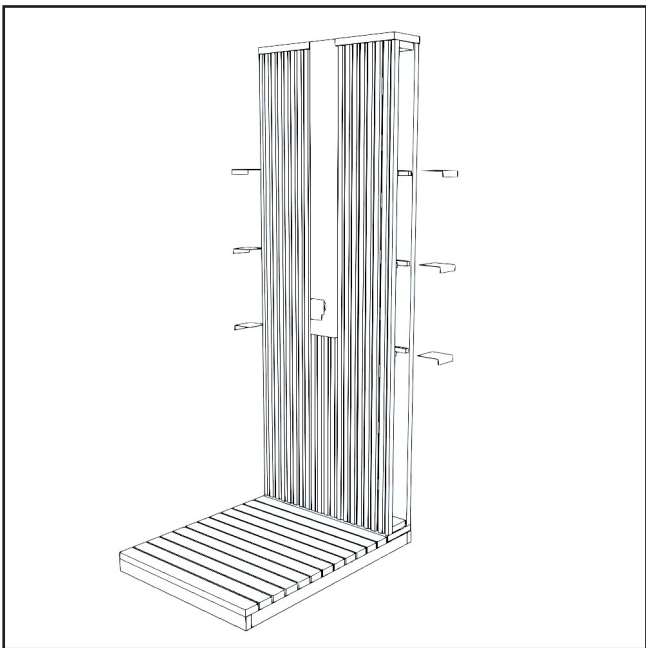

Suihkuseinällä olevissa ulkosuihkuissa on sivuilla hyllynkannattimet, asettele hyllyt kannattimiin.

TAKUU

Myönnämme saunallemme 24 kuukauden takuun materiaali- ja valmistusvirheille. Takuu on voimassa kun käyttäjä on tutustunut tuotteen käyttöohjeisiin ja noudattaa niitä.

HUOM! Yllämainitusta poikkeaa kaupallisiin tarkoituksiin käytettäville tuotteille myönnetty 6 kuukauden takuu-aika.

- Takuu ei koske sellaisia mahdollisesti ilmeneviä virheitä, jotka ovat tyypillisiä puumateriaaleille. Esim. värimuutokset, kosteusvaihtelut, halkeamien muodostuminen ja vastaavat.
- Takuu ei koske normaalia käytöstä aiheutunutta kulumista.
- Takuu ei myöskään korvaa käyttövirheistä aiheutuneita vaurioita.
- Takuu ei korvaa mitään pakkasen aiheuttamia vaurioita, koska ne voidaan välttää oikealla käytöllä.
- Takuu ei koske virheellisestä pesuaineiden käytöstä aiheutuvasta mahdollista syöpmistä.
- Takuu ei kata mitään välillisiä kuluja, esim. terassin rakentamisia tai purkuja.

Ota takuuasioissa heti yhteyttä tuotteen myyjään. Itsenäiset tuotteen korjausyritykset johtavat takuun raukeamiseen.

TUOTTEEN HÄVITTÄMINEN

Tuotteen metalliset osat tulee viedä metallinkierrätykseen, puuosat voidaan hävittää polttamalla, lasi viedään lasinkeräykseen. Muut osat kuuluvat sekajätteeseen. Käytetyt Led-valot voi Suomessa palauttaa maksutta ja ilman uuden tuotteen ostovelvoitetta myymälöihin, joiden valikoimiin lamput sisältyvät tai vaihtoehtoisesti viedä kierrätyspisteeseen.

Kirami FinVision® -outdoor shower XL Misty



Bruksanvisning

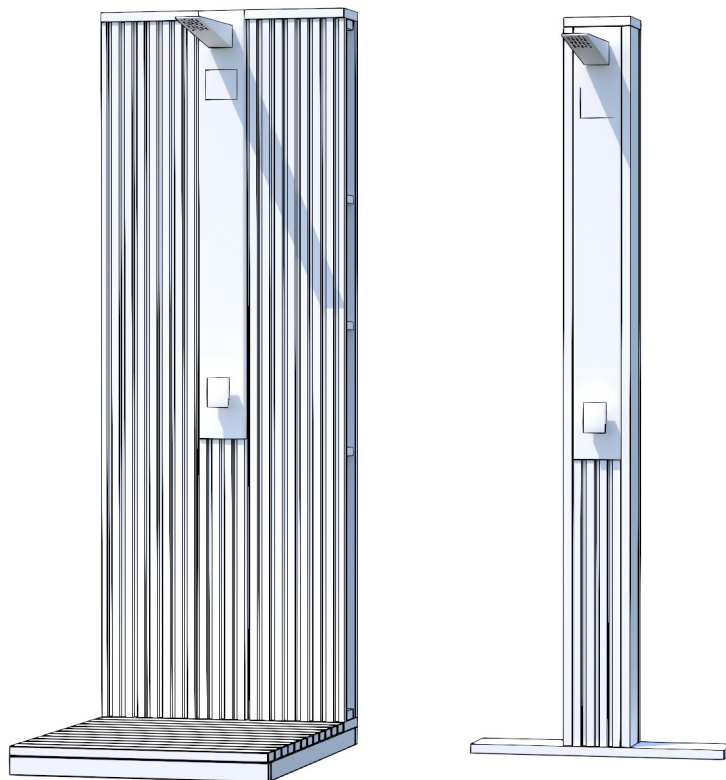

Kontrollera leveransinnehållet omedelbart!
Läs noggrant igenom och spara anvisningarna för
framtida behov.

ALLMÄNT

Om du beställer duschen i samband med terrassen, är uteduschmodulen färdigmonterad på terrassen. Duschväggen kan också monteras i efterhand, varvid den levereras i delar.

Duschen har färdigdragna kopplingar, som du om du vill kan ansluta till rör för både kallt och varmt vatten eller till trädgårds-slangen.

Golvtrallen i duschar utrustade med underlag kan tas loss. Under trallen finns ett tråg av galvaniserad plåt, som leder tvättvattnet till avloppsröret.

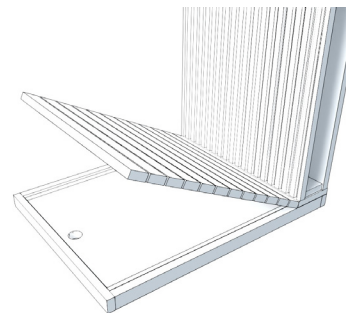

LEVERANSKONTROLL

Vi rekommenderar alltid att du innan du skriver på fraktsedeln kontrollerar att du har emottagit en oskadad förpackning. Om du vid ett senare tillfälle upptäcker att det saknas någonting i uteduschens innehåll, ska du kontakta leverantören.



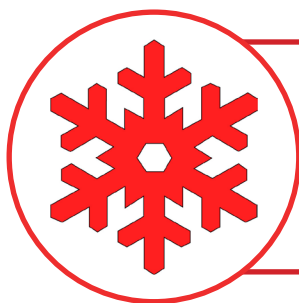







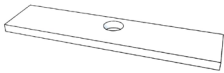

Om du beställde uteduschen samtidigt som de andra modulerna kan du gå till avsnitten "ANSLUTNING FÖR VATTENINTAG" och "ANSLUTNING FÖR VATTENAVLOPP".

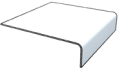
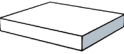

OBS! Vintertid ska utomhusduschen tömmas på vatten för att undvika frostsador.

Öppna kranen och blås luft genom systemet.

STYCKELISTA

Nro	Kuva	Nimi	Pilari (Ilman alustaa)	Pilari (Alustalla)	Suihkuseinä (Terassimalli)	Suihkuseinä (Ulkomalli)
1.		Duschgolv			1	1
2.		Bottenplanka för pelare	1	1		
3.		Duschvägg			1	1
4.		Pelare	1	1		
5.		Duschhuvud (inkl. bricka och mutter)	1	1	1	1
6.		Vattenavledningsrör		1	1	1
7.		Skarvplåt till tak			1	
8.		Hylla			6	6
9.		Skydd - Pelare	1	1		
10.		Skyddsplåt				1
11.		Skruv 5x35 mm			8	
12.		Skruv 4,2 x 19 mm		10	10	10
13.		Skruv 4,8x25				4
14.		Skruv 4,8 x 75 mm	12	12	4	6

PLACERING

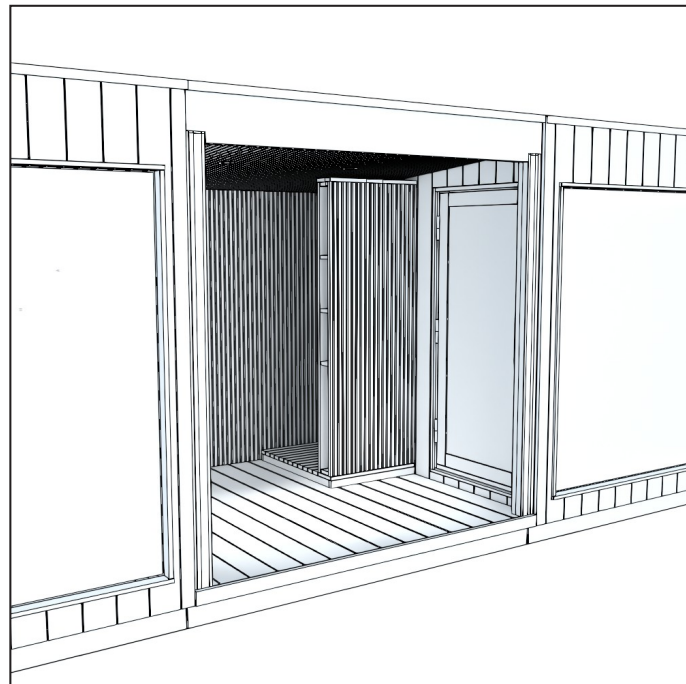
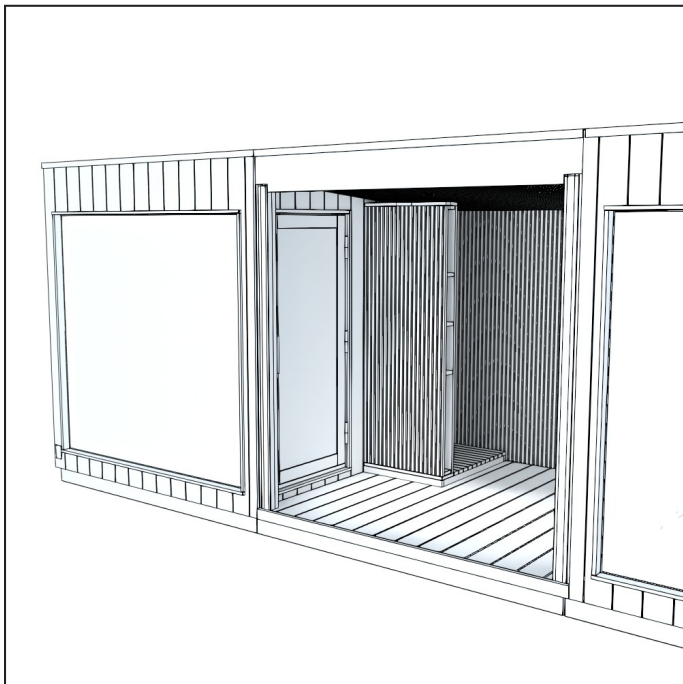

Kirami FinVision® -utedusch Misty (terrassmodell) monteras alltid innanför Kirami FinVision® -terrassen och alltid antingen i den vänstra eller högra kanten, med ena sidan mot en annan modul.

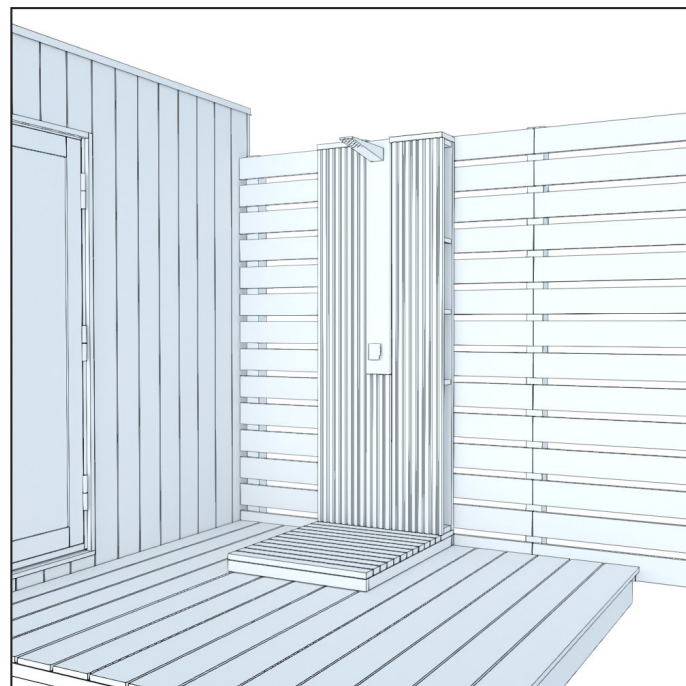
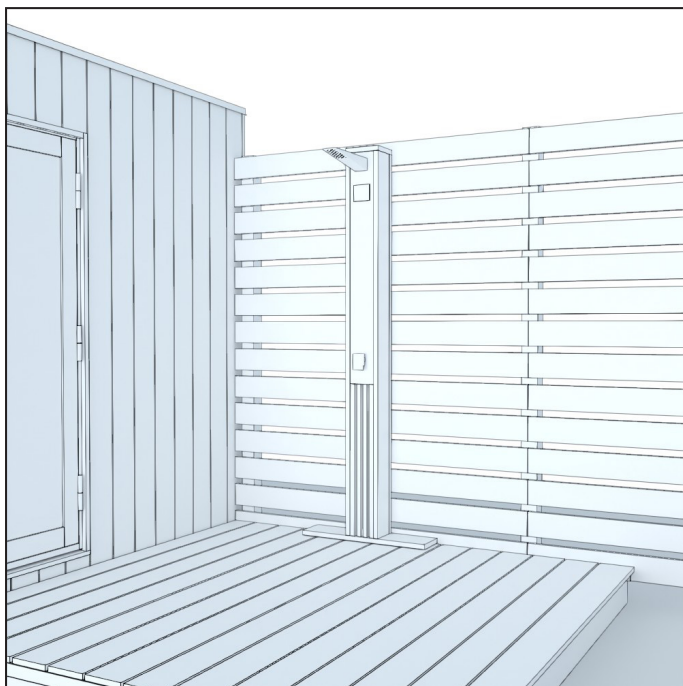

Kirami FinVision® -uteduschen (utomhusmodell) och Pilari-modellerna kan monteras på vilket jämnt underlag som helst, till exempel på en utomhus- eller takterrass, i anslutning till en badtunna, en pool eller en bastu.

Det rekommenderas alltid att uteduschar monteras i väggen eller mot någon annan stabil struktur.

MONTERING

Pelare

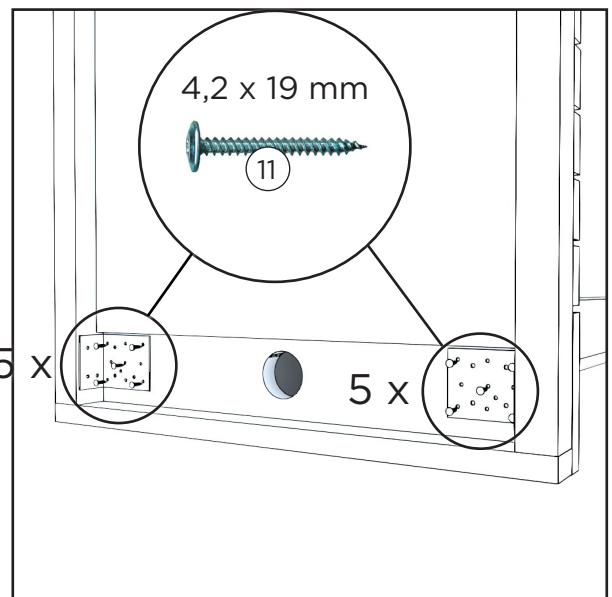
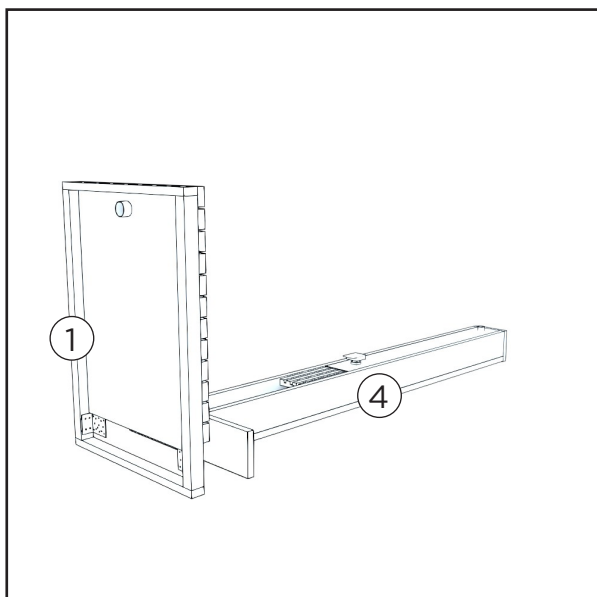
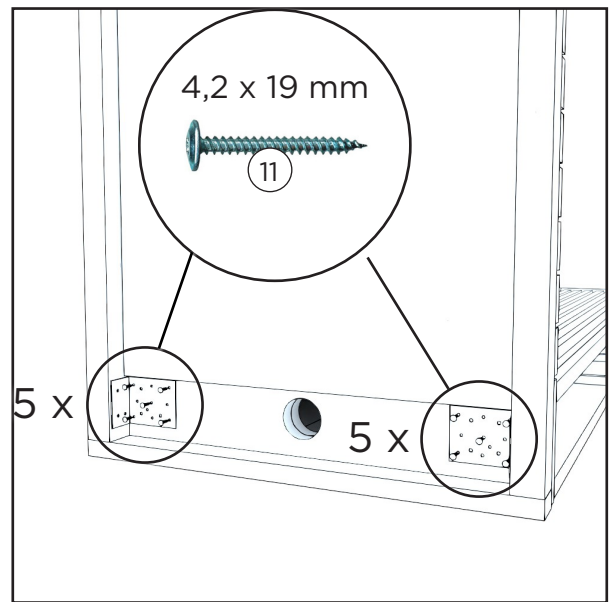
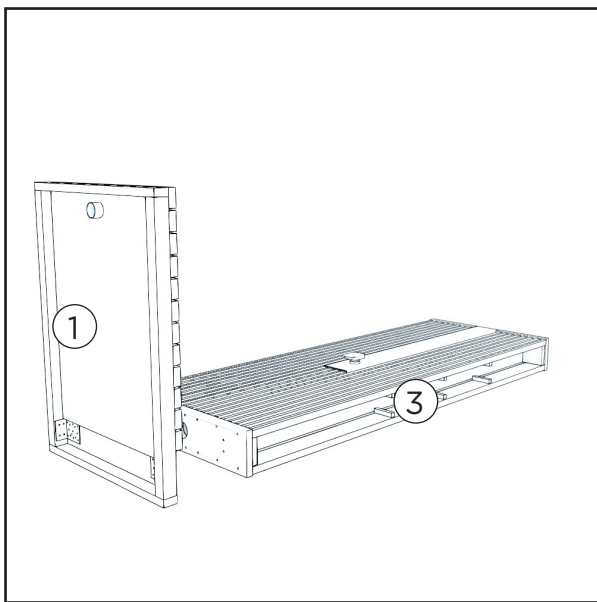
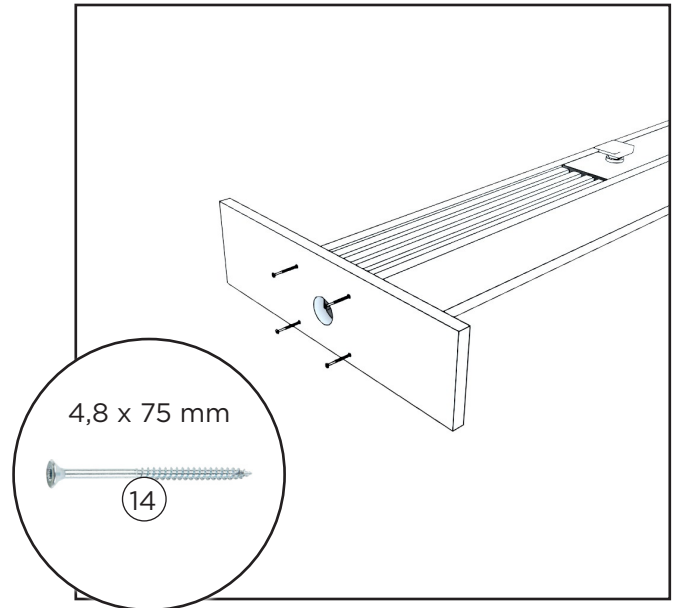
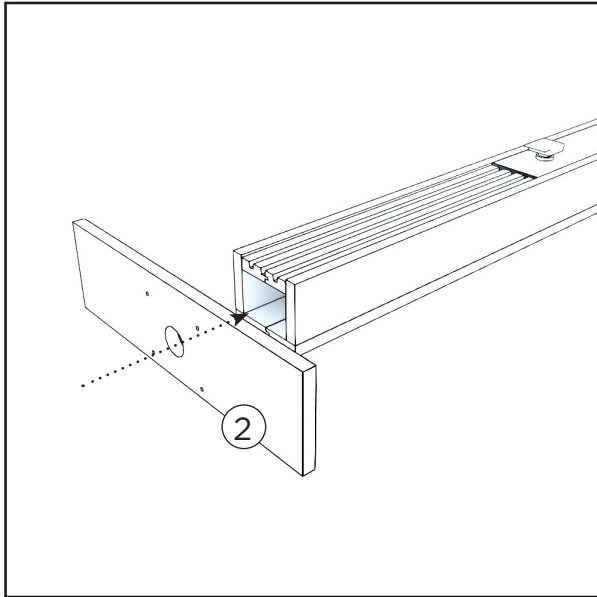

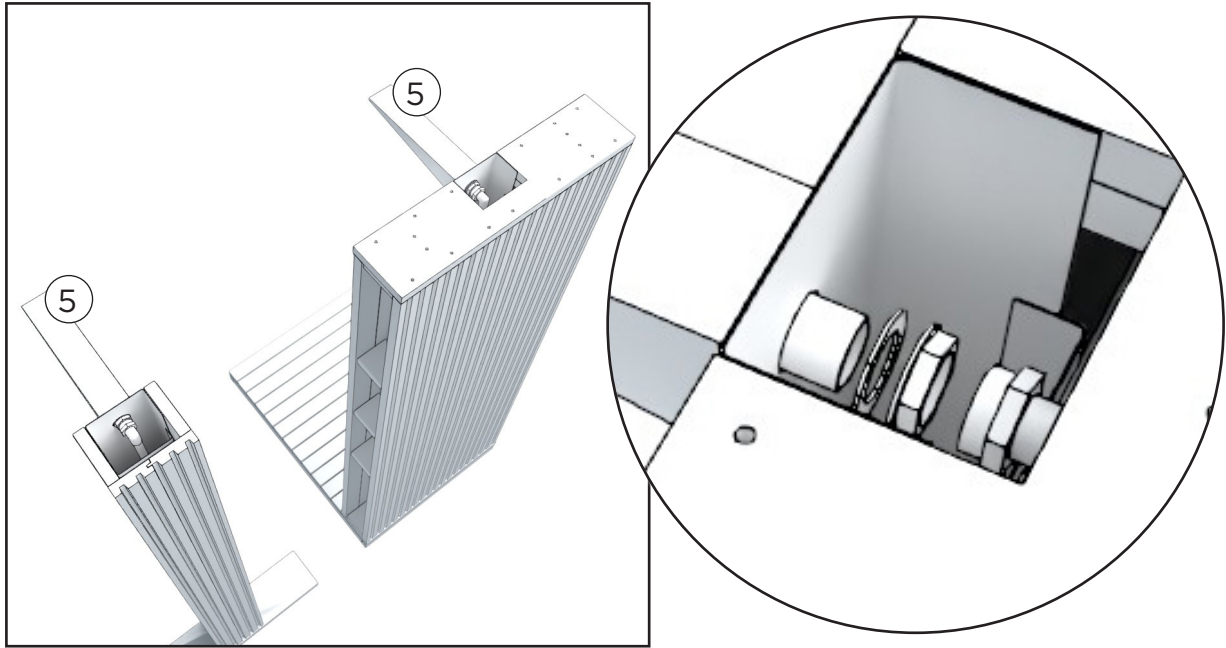

Anslut duschhuvudet först till skivan av rostfritt stål med en mässingmutter, observera att en bricka ska läggas mellan den rostfria skivan och mässingmuttern. Ta bort tejpén från hörnet i duschen och fäst den på duschhuvudet.

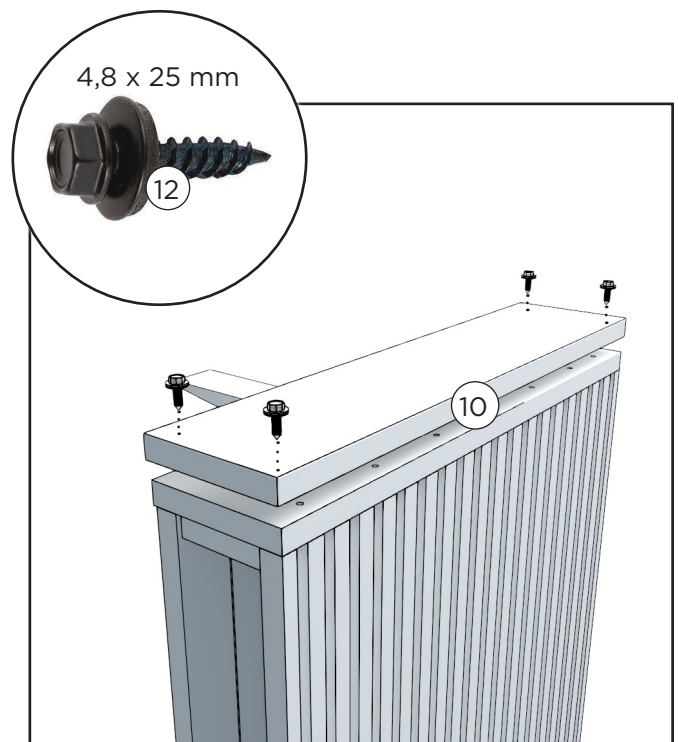
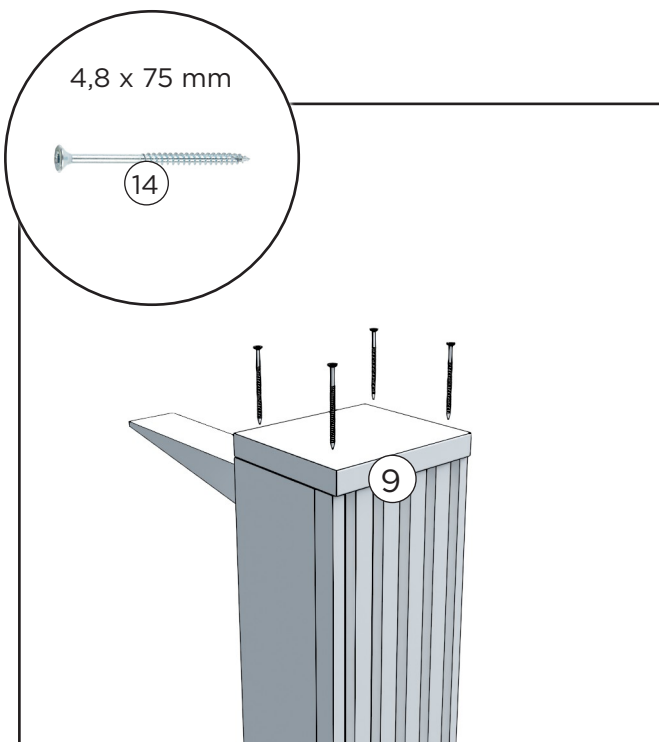

Pelarmodell: Anslut ändan till uteduschen med fyra skruvar.

Utedusch (utomhusmodell): Anslut skyddsplåten till ändan av uteduschen med fyra skruvar.

Obs! Inget skydd monteras på duschen i terrassmodellen.

MONTERING AV UTEDUSCHEN PÅ EN TERRASS

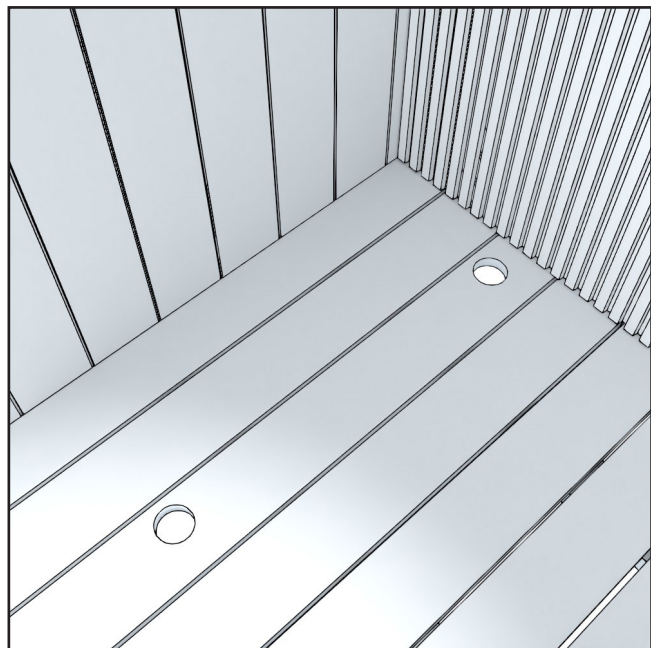
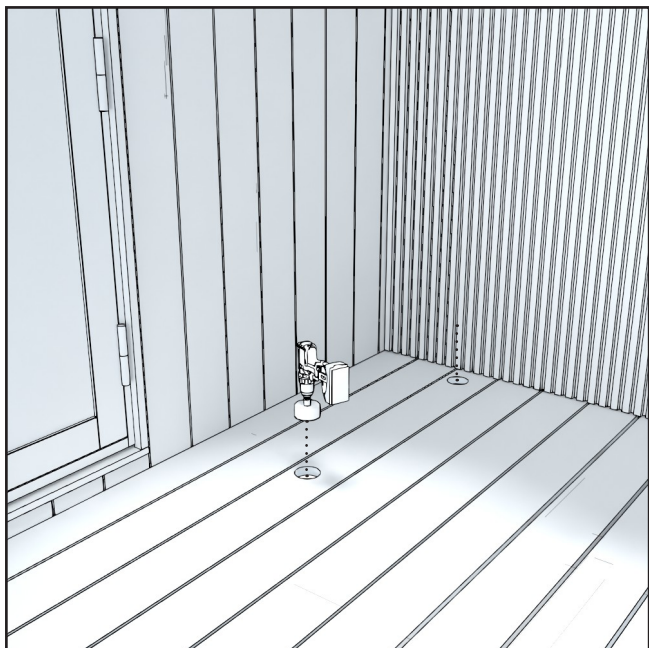

När Kirami FinVision® -utedusch Misty beställs i efterhand ska hålen för vattenintag och -avlopp borras i terrassmodulen. Diametern på hålet som ska borras i terrassen är minst 73 mm.

Mått för montering på vänster sida:

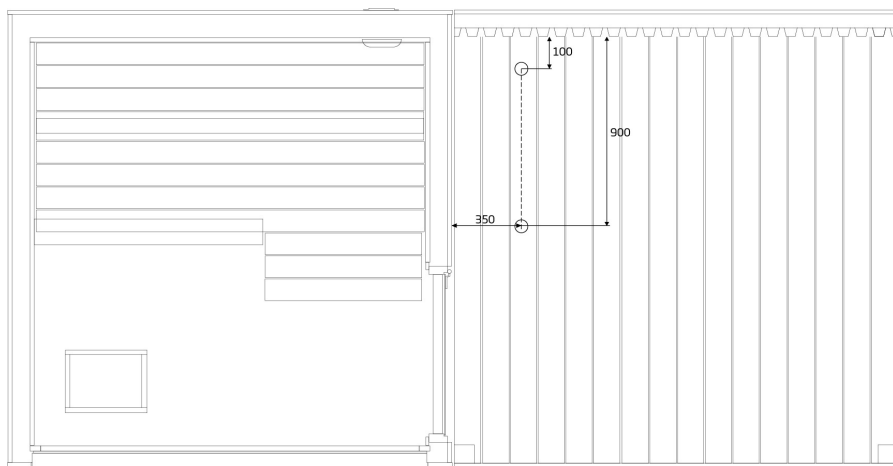

Mått för montering på höger sida:

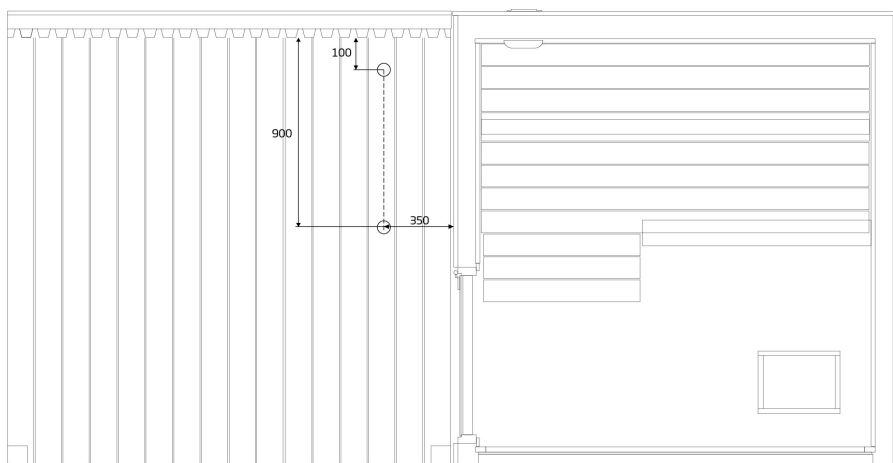

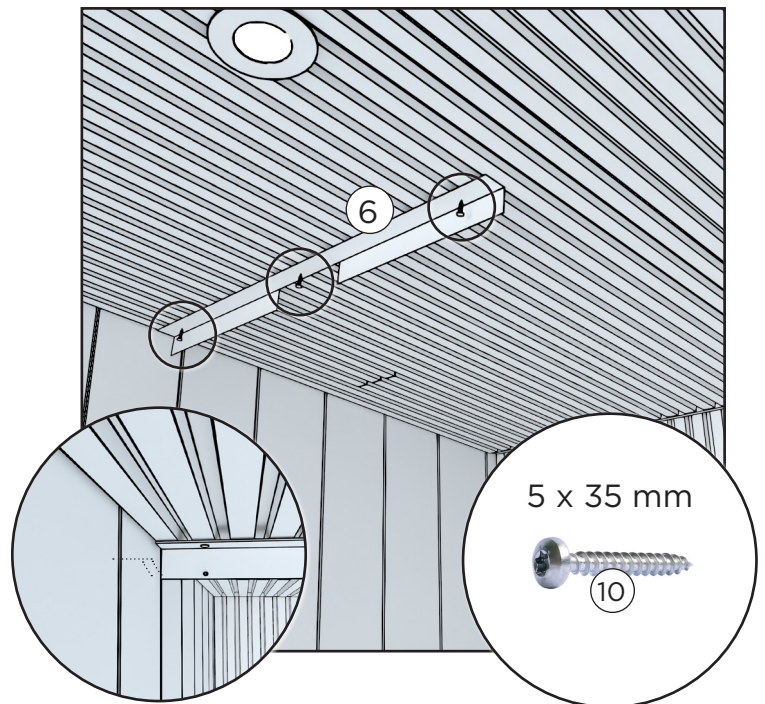
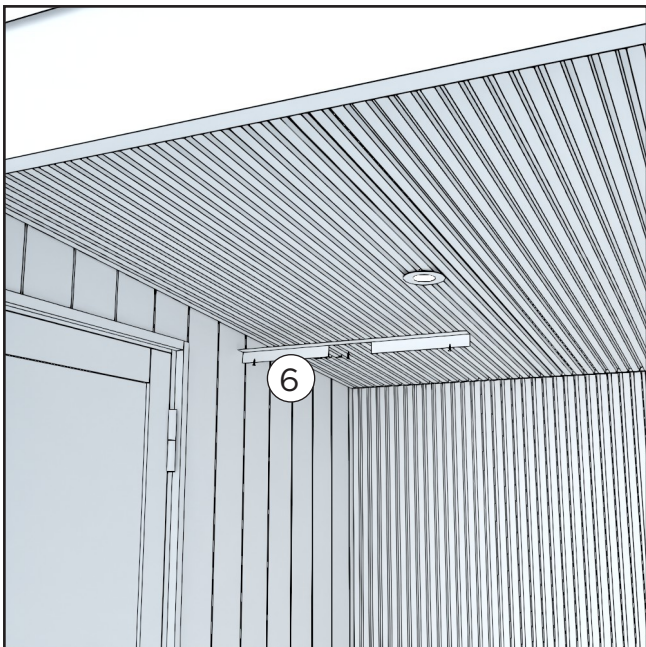

Montera uteduschens och takets skarvplåt i terrassens innertak, 830 mm från bakväggen och 3-5 mm från sidoväggen.

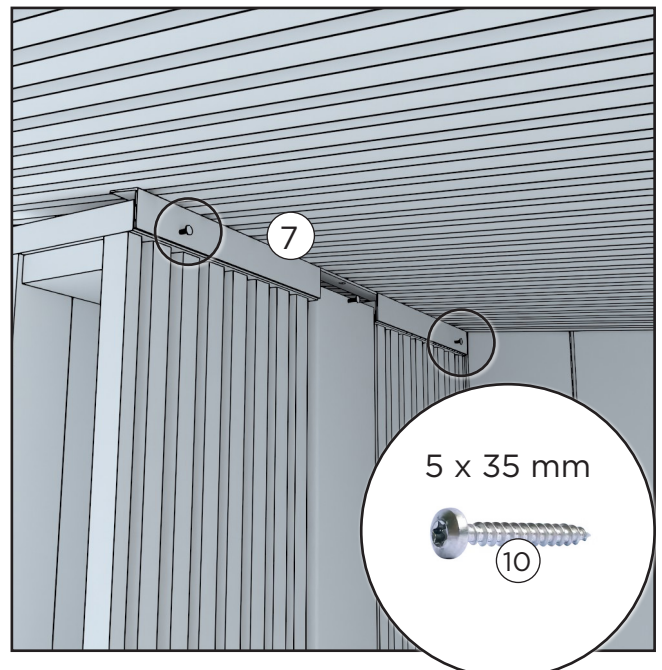
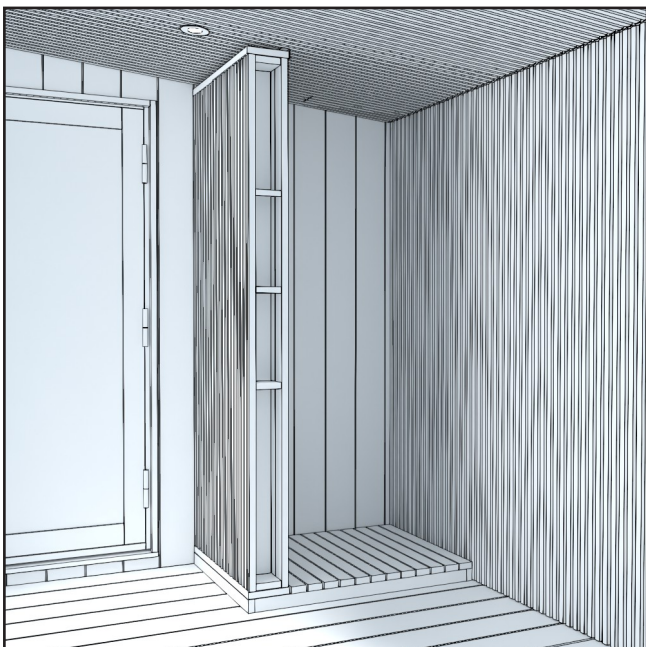

Placera uteduschen mot skarvplåten och terrassens bakvägg. Montera skarvplåten i uteduschen med skruvar.

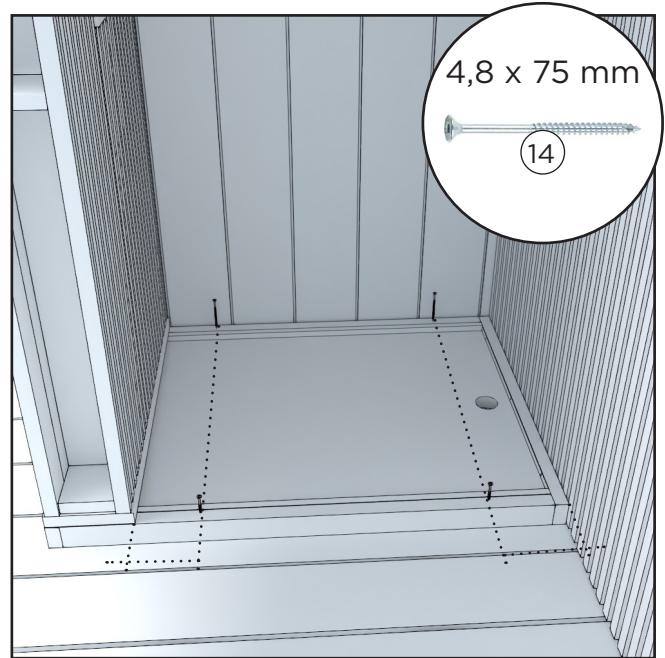
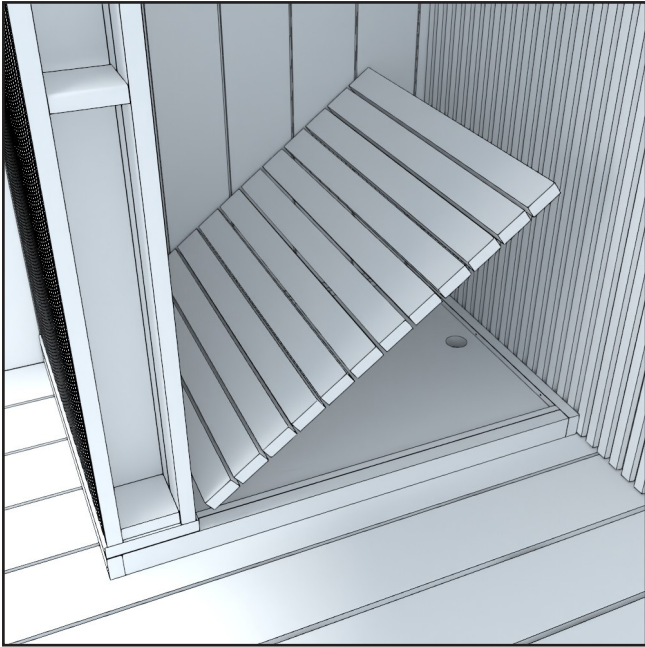

Lyft bort underlagets galler och montera fast underlaget i terrasdäcket med skruvar.
Avsluta med att lägga tillbaka underlagets galler.

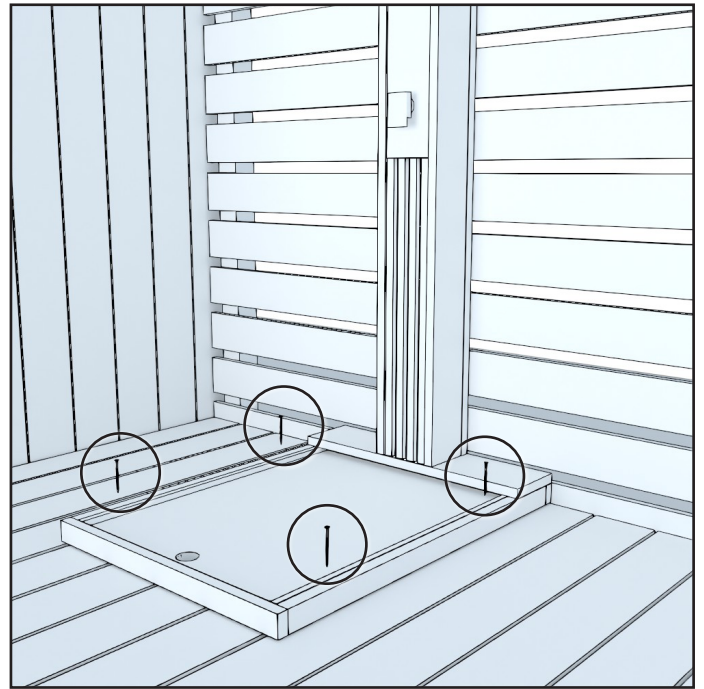
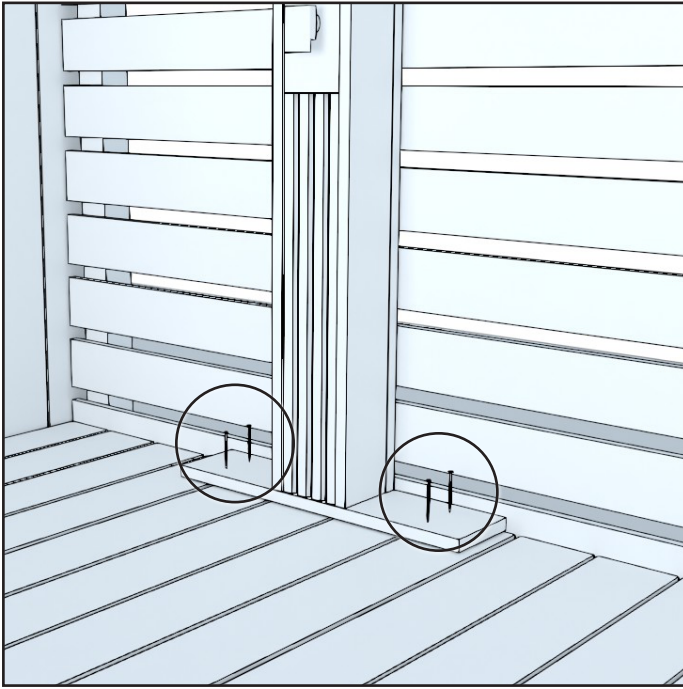
MONTERING AV ANDRA MO-
DELLER

I pelarmodellens utedusch ska du montera uteduschens underlag i materialet under med fyra skruvar.

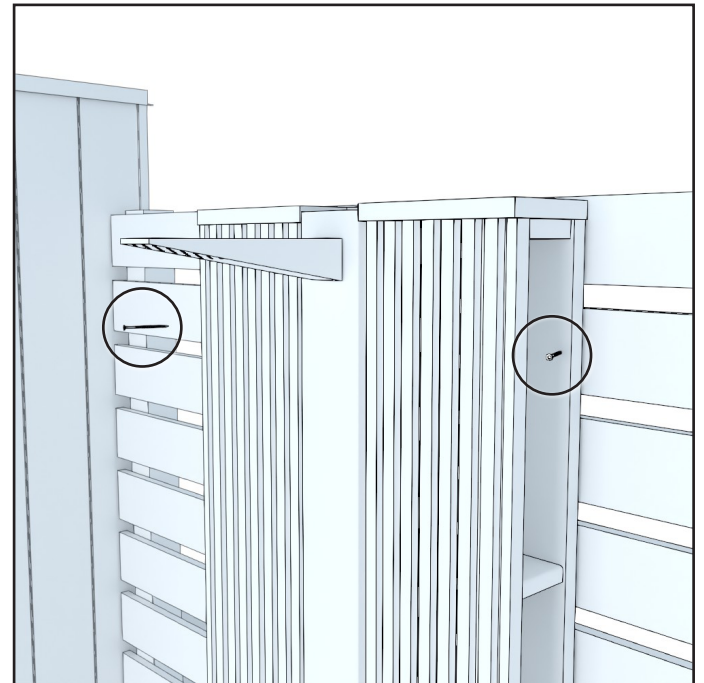
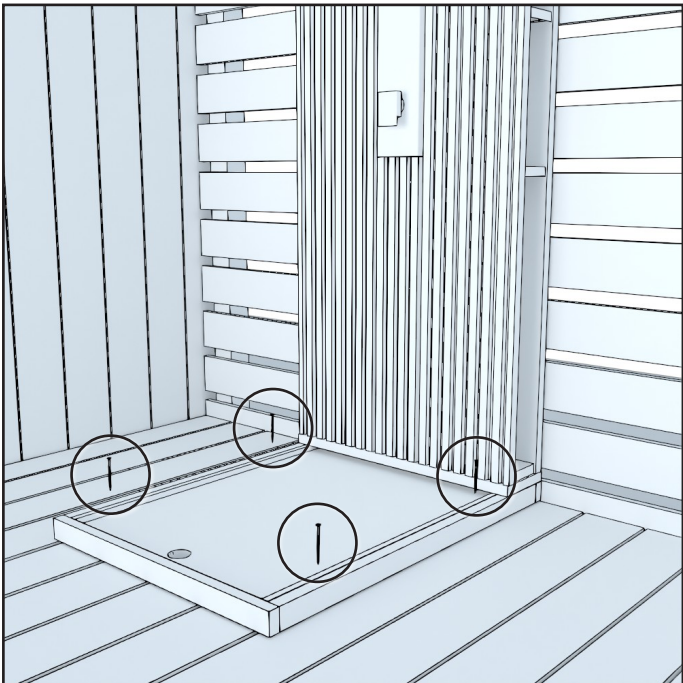

I den väggmonterade uteduschen ska du först montera underlaget i materialet under med fyra skruvar. Fäst väggens överdel i det motstående materialet på båda sidorna med två skruvar.

ANSLUTNING FÖR VATTENINTAG

Duschen har färdigdragna kopplingar, som du om du vill kan ansluta till rör för både kallt och varmt vatten eller till trädgårdsslangen.

ANSLUTNING TILL EN TRÄDGÅRDSSLANG

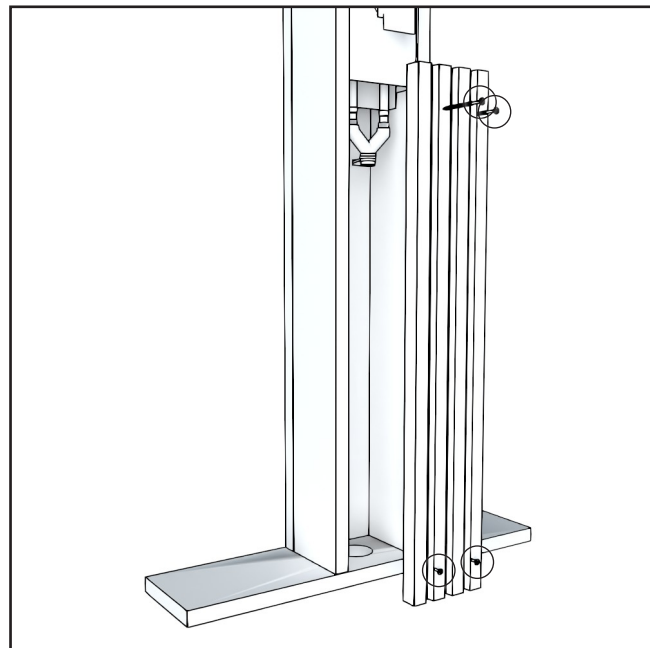
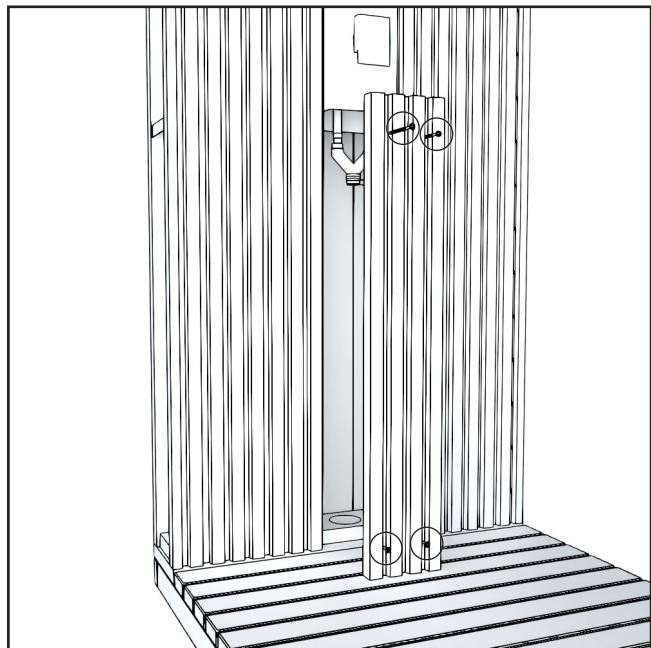

1. Kopplingarna för tillvatten finns under de främre panelerna. Ta loss panelerna.

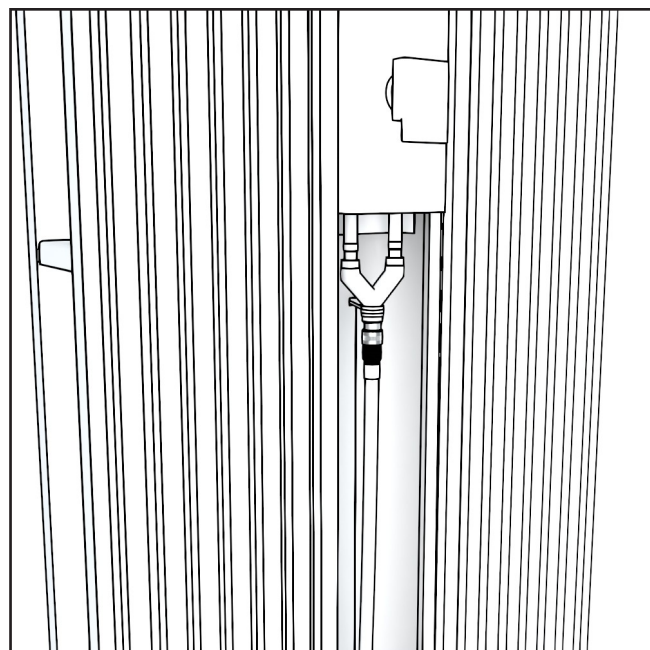

2. För trädgårdsslangen genom hålet under uteduschen in i väggen och anslut den till duschen.

När slangens är ansluten, ska du fästa de två panelerna tillbaka.

ANSLUTNING TILL VARMT OCH KALLT VATTEN

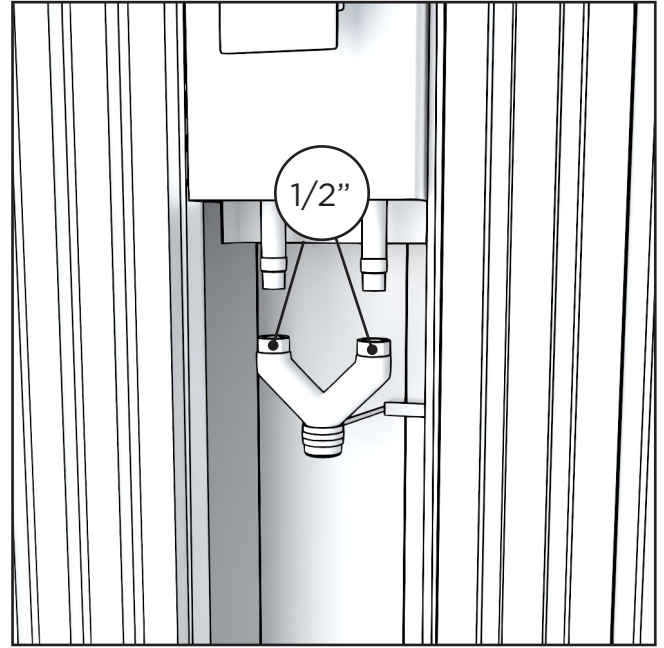
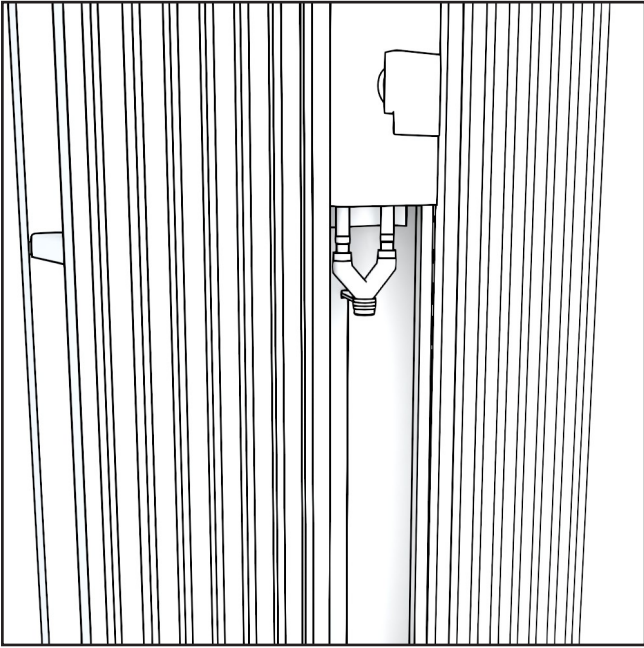

1. Ta bort mässingsrördelaren genom att vrida muttrarna moturs och ta bort fästet från väggen.

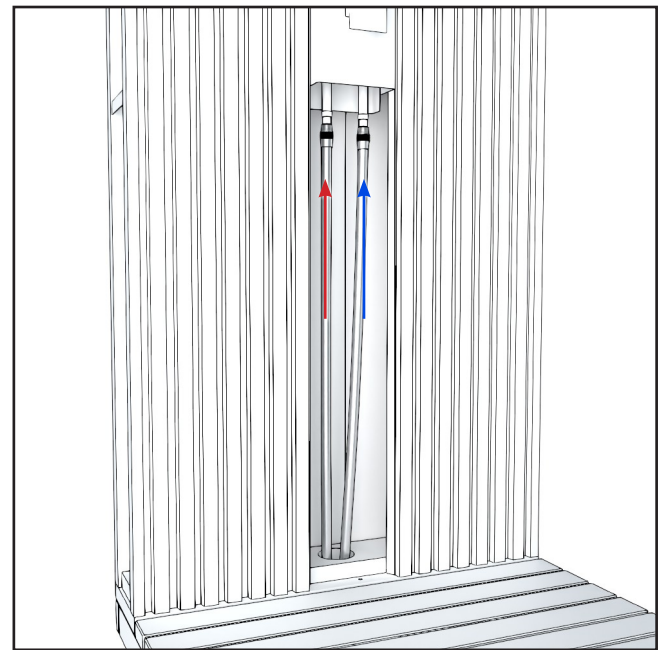
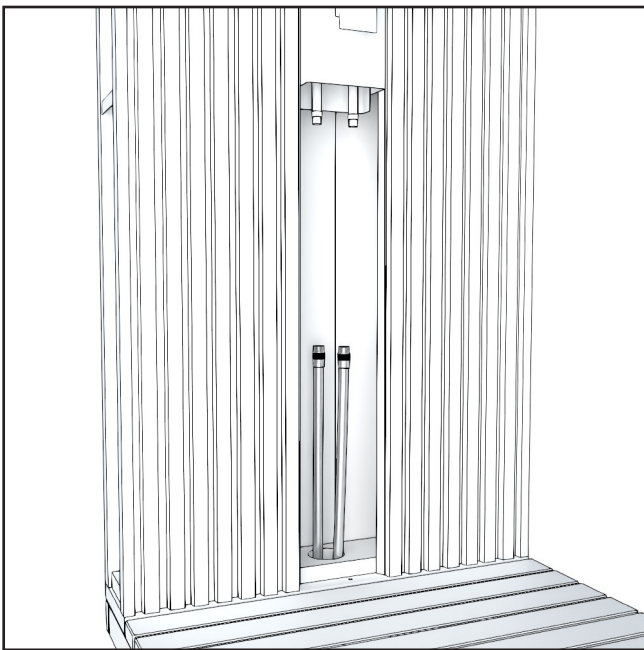

2. Trä trädgårdsslangen/rören genom väggens hål som du borrar i terrassen, och hålet under uteduschen. Fäst varmt vatten på vänster sida och kallt på höger sida.

När slangarna/rören är kopplade skruvar du tillbaka de två panelerna.

ANSLUTNING AV VATTENAVLOPP

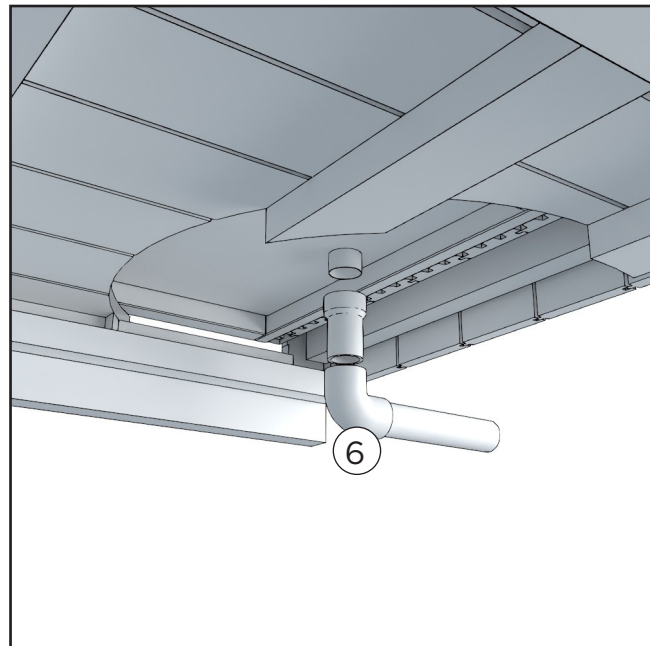
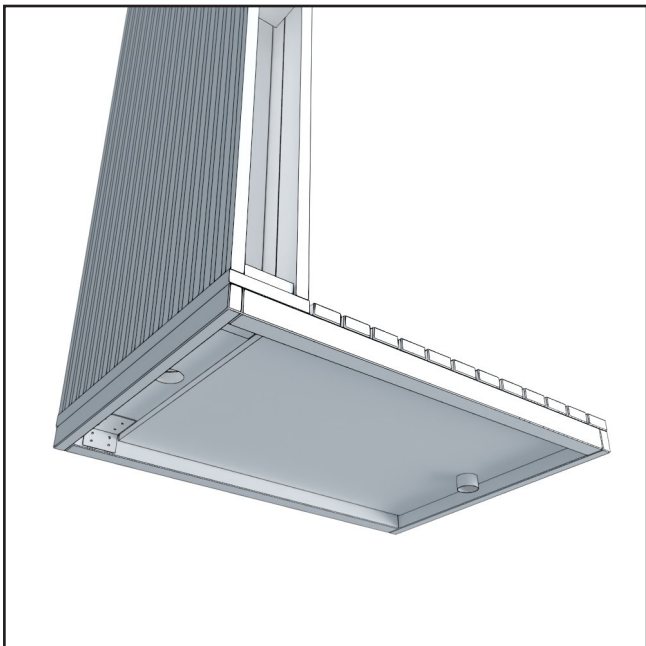

Underlaget har ett färdigt 50 mm stort avloppsutlopp för tvättvattnet. Vid montering av Kirami FinVision® -terrassen, ska du ansluta rördelarna i den ordning som anges på bilden, varvid uteduschens vattenavledning hamnar bakom modulen.

PLACERING AV HYLLORNA

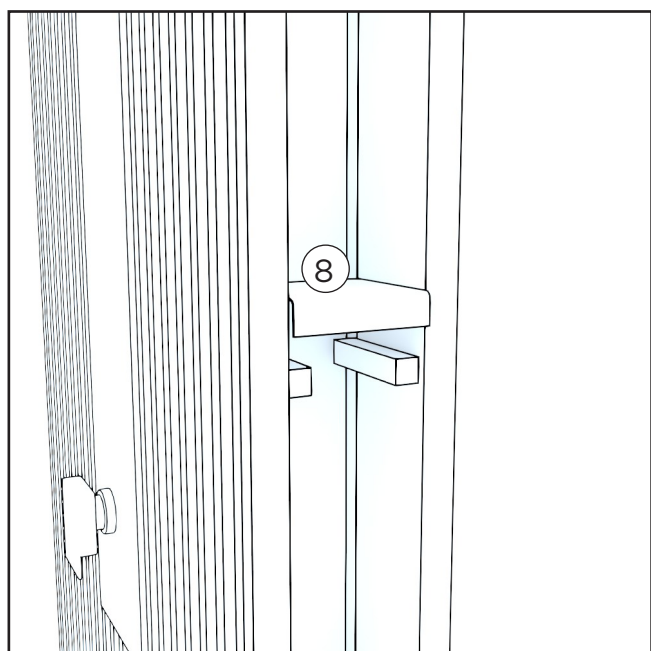
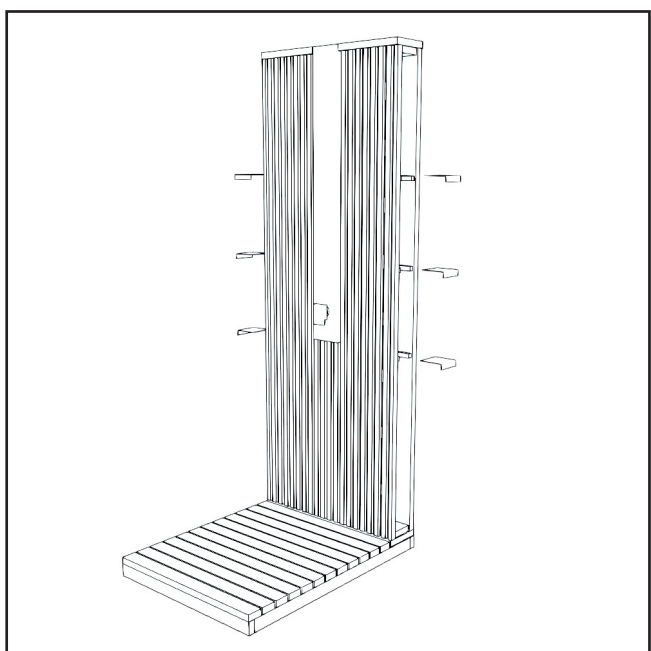

I uteduscharna med duschvägg finns hyllfästen på sidorna. Placera hyllorna på dessa fästen.

GARANTI

Vi lämnar 24 månaders garanti för vår bastu för material- och tillverkningsfel. Garantin gäller om användaren har läst produktens bruksanvisning och följer den.

OBS! Från ovanstående avviker den sex månader långa garantin som lämnas för produkter i kommersiellt bruk.

- Garantin gäller inte sådana eventuella fel, som är typiska för trämaterial. Exempel på dessa är färgförändringar, fuktighetsväxlingar, förekomst av sprickor och motsvarande.
- Garantin gäller inte normalt slitage på grund av användning.
- Garantin ersätter inte heller skador som har orsakats av felaktig användning.
- Garantin ersätter inga skador som orsakats av köld, eftersom dessa kan undvikas genom korrekt användning.
- Garantin gäller inte eventuella frätskador, som beror på användning av felaktiga rengöringsmedel.
- Garantin täcker inga indirekta kostnader, till exempel bygge eller rivning av terrass.

Kontakta försäljaren av produkten omedelbart i garantiärenden. Om du på egen hand försöker reparera produkten upphör garantin att gälla.

ÅTERVINNING AV PRODUKTEN

Produktens metalldelar ska lämnas till metallåtervinningen, trädelarna kan brännas upp och glaset lämnas till glasåtervinningen. Övriga delar tillhör blandavfall. I Finland får förbrukade LED-lampor återlämnas kostnadsfritt och utan tvång att köpa en ny produkt till alla butiker vars sortiment omfattar lamporna. Alternativt kan lamporna lämnas till en återvinningsstation.

Kirami FinVision® -outdoor shower XL Misty



Instructions for installation

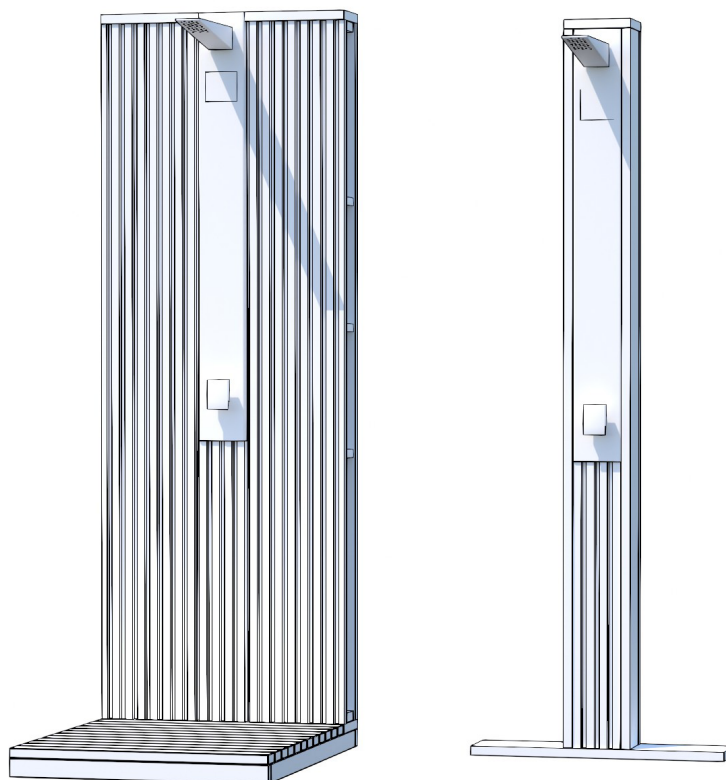

Check the contents of the delivery without delay!
Study the instructions carefully and keep them for future reference.

GENERAL

If you order the shower with the terrace, the outdoor shower module is pre-fitted to the terrace. The shower wall can also be installed afterwards, in which case it is supplied in parts.

The shower is equipped with pre-assembled connections, which can be connected to both hot and cold water pipes or, alternatively, to a garden hose.

The floor grating of the platform-equipped shower is removable. Beneath the grating, there is a trough made of galvanized sheet metal, which directs the wash water to the drainage pipe.

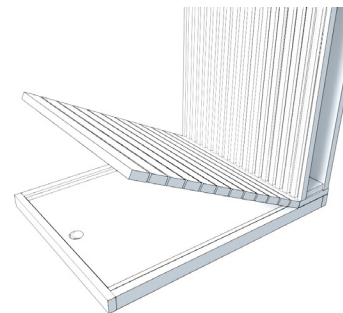

CHECKING THE DELIVERY

We recommend that you always check that you have received intact pallet before signing the waybill. If you notice later that there is something missing from the contents, please contact the party that delivered the product.



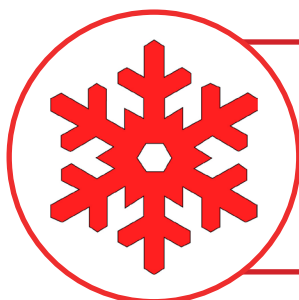







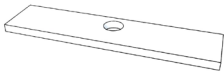

If you ordered the outdoor shower at the same time as the other modules, you can go to the sections "INLET WATER CONNECTION" and "WATER DRAINAGE CONNECTION".

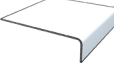
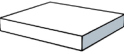

NOTE! For winter, the outdoor shower must be drained of water to prevent frost damage.

Open the tap and blow compressed air through the system.

PART LIST

Nro	Kuva	Nimi	Pilari (Ilman alustaa)	Pilari (Alustalla)	Suihkuseinä (Terassimalli)	Suihkuseinä (Ulkomalli)
1.		Base			1	1
2.		Bottom plank for pillar	1	1		
3.		Wall			1	1
4.		Pillar	1	1		
5.		Showerhead (includes washer and nut)	1	1	1	1
6.		Drainage pipe		1	1	1
7.		Connecting plate to the ceiling			1	
8.		Shelf			6	6
9.		Protector - Pillar	1	1		
10.		Protector plate				1
11.		Screw 5x35 mm			8	
12.		Screw 4,2 x 19 mm		10	10	10
13.		Screw 4,8x25				4
14.		Screw 4,8 x 75 mm	12	12	4	6

PLACEMENT

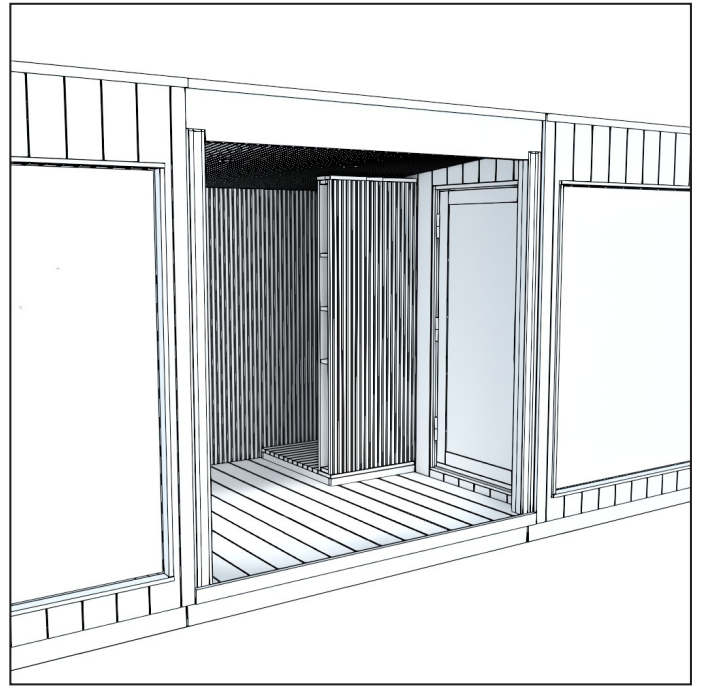
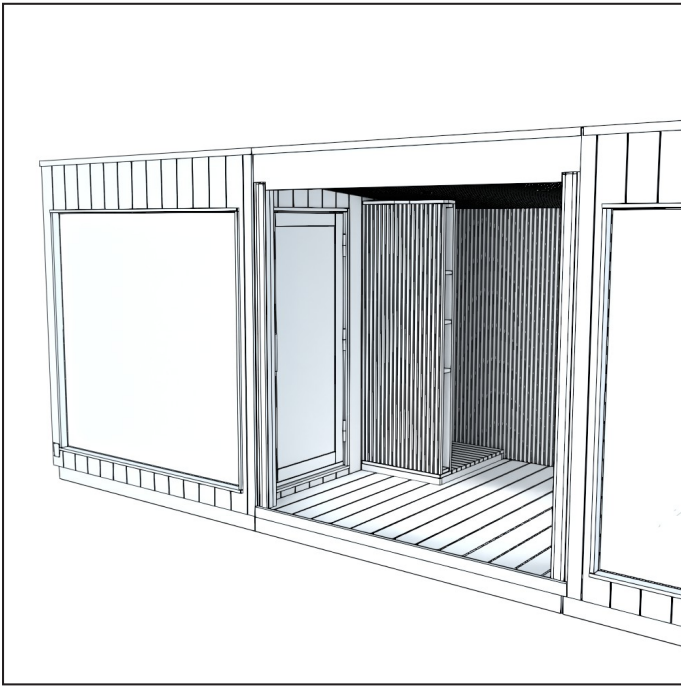

The Kirami FinVision® Misty outdoor shower (terrace model) is always installed inside the Kirami FinVision® terrace, either on the left or right edge, so that one side of the outdoor shower is against another module.

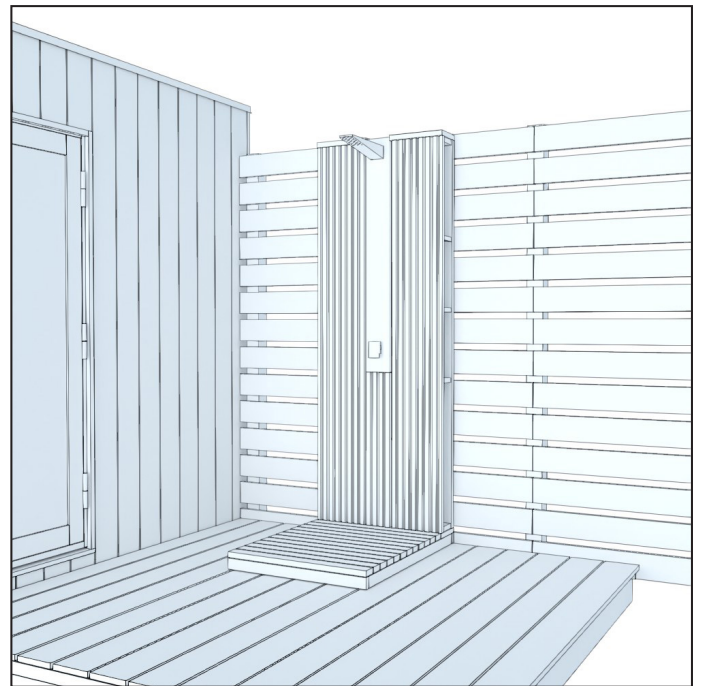
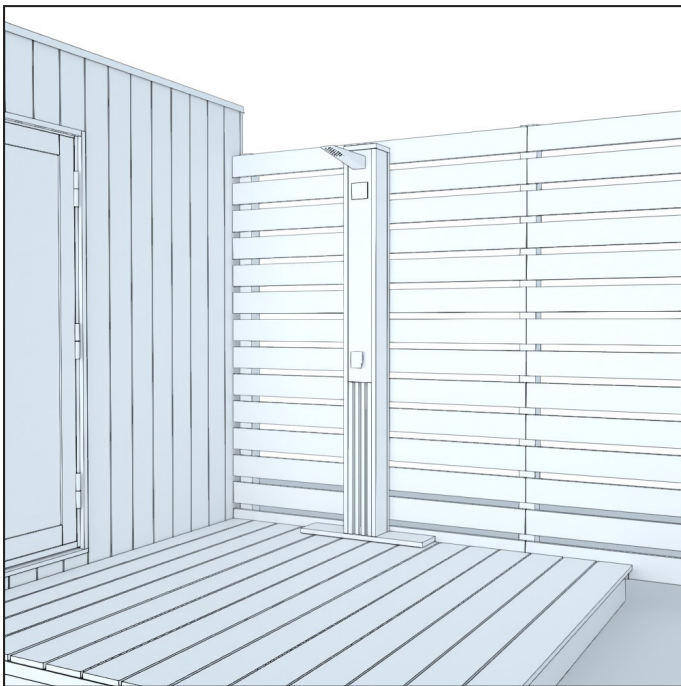

The Kirami FinVision® -outdoor shower (off terrace model) and Pillar models can be installed on any flat surface, such as an outdoor or rooftop terrace, near a hot tub, swimming pool, or sauna.

It is always recommended to install outdoor showers against a wall or other stable structure.

ASSEMBLY

Pillar

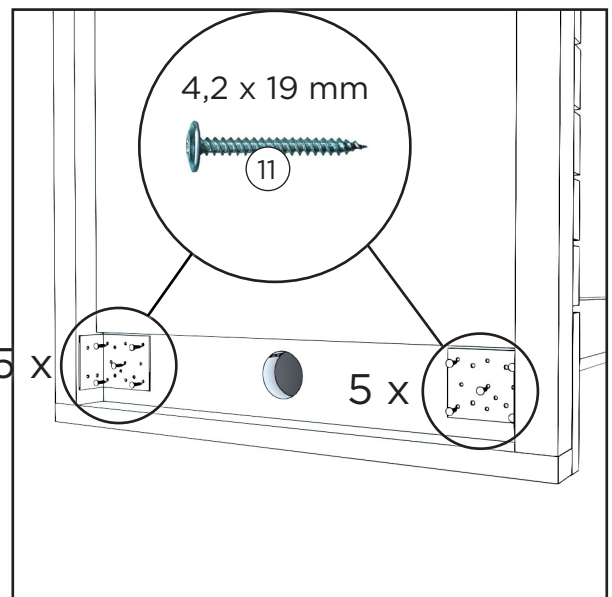
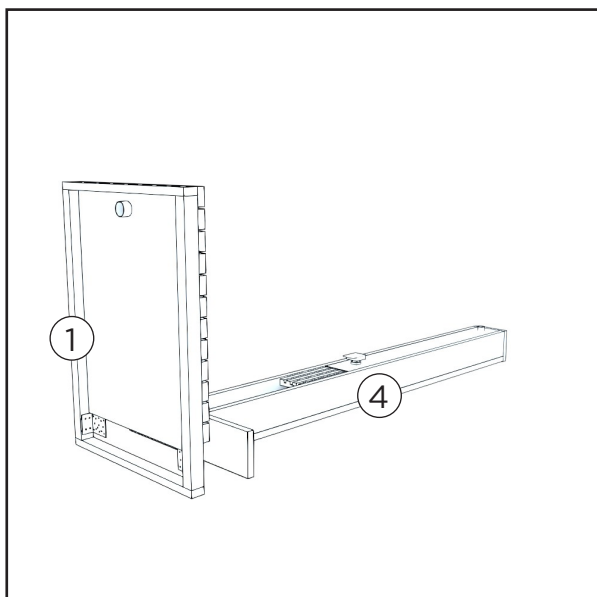
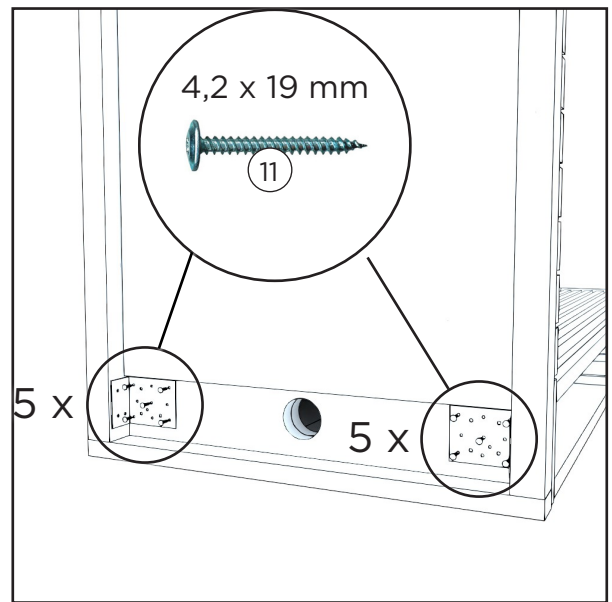
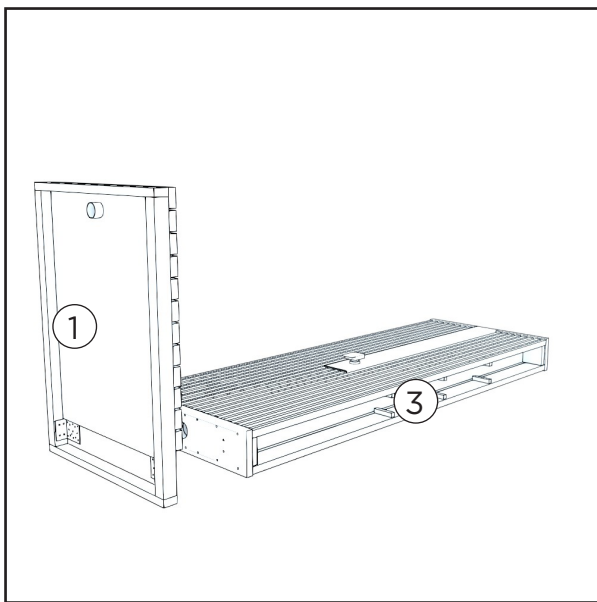
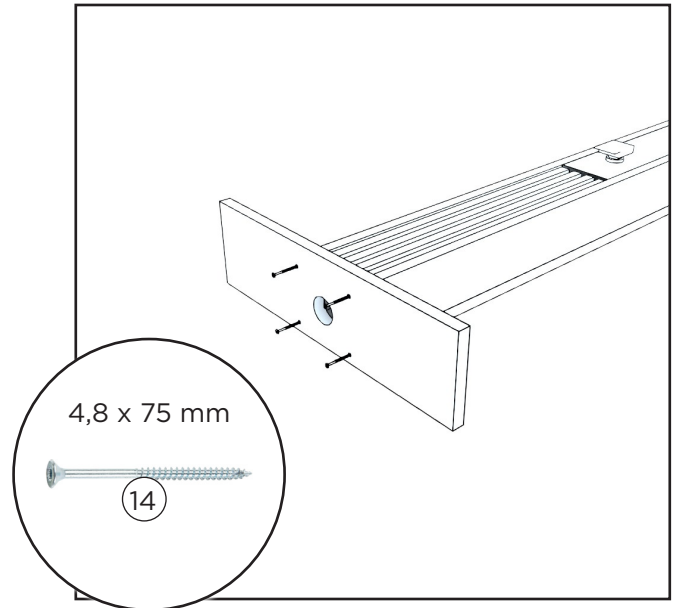
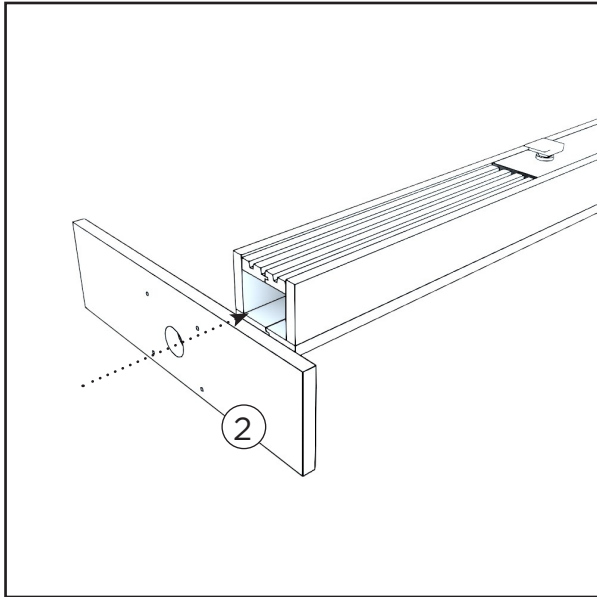

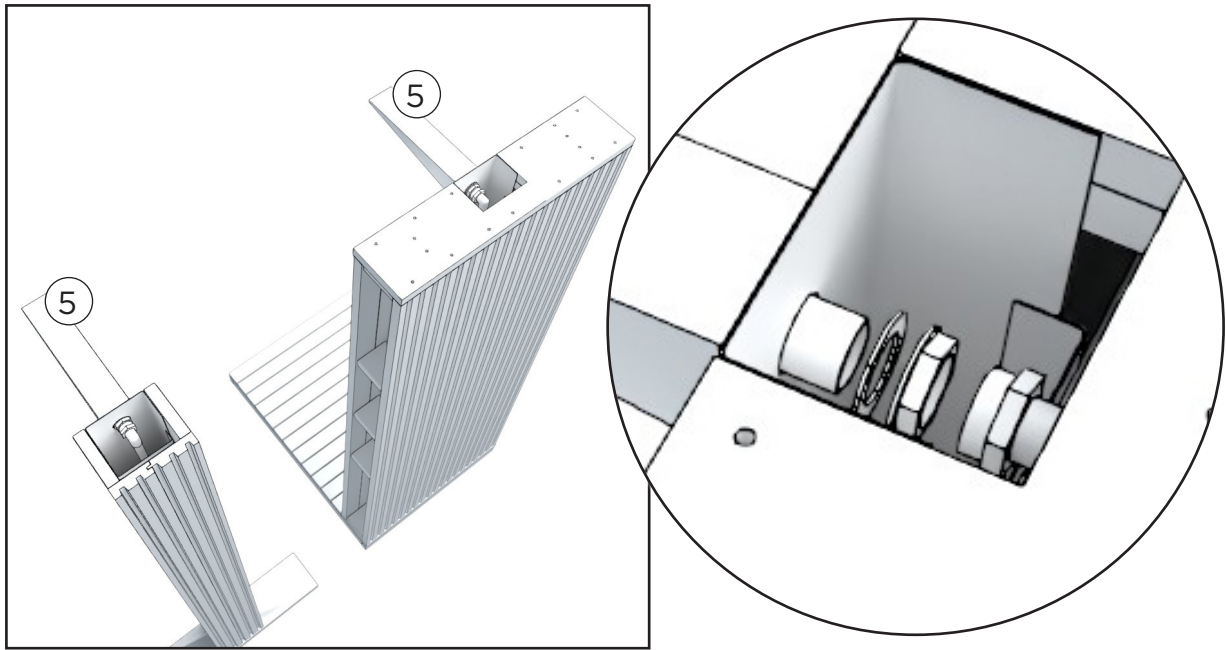

Attach the shower head first to the stainless steel plate using a brass nut; note that a washer should be placed between the stainless steel plate and the brass nut. Remove the tape from the elbow inside the shower and connect it to the shower head.

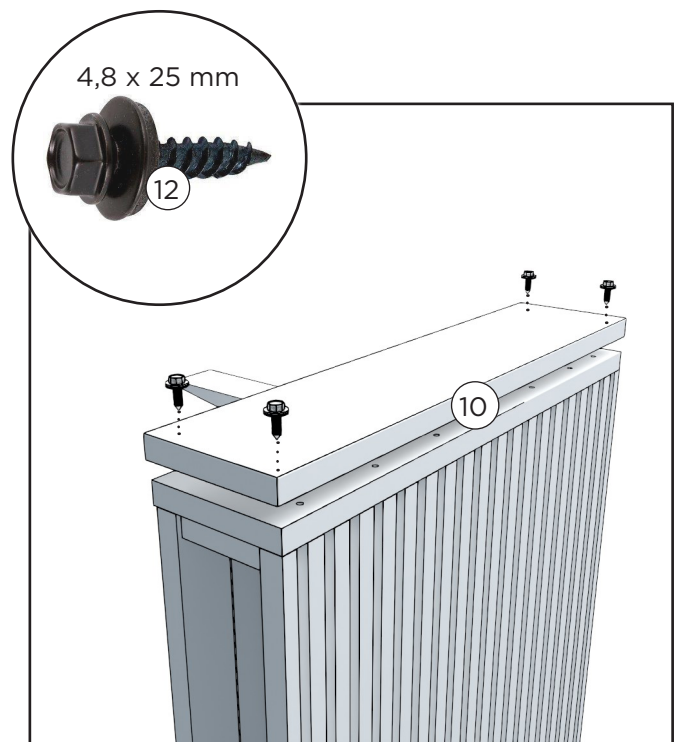
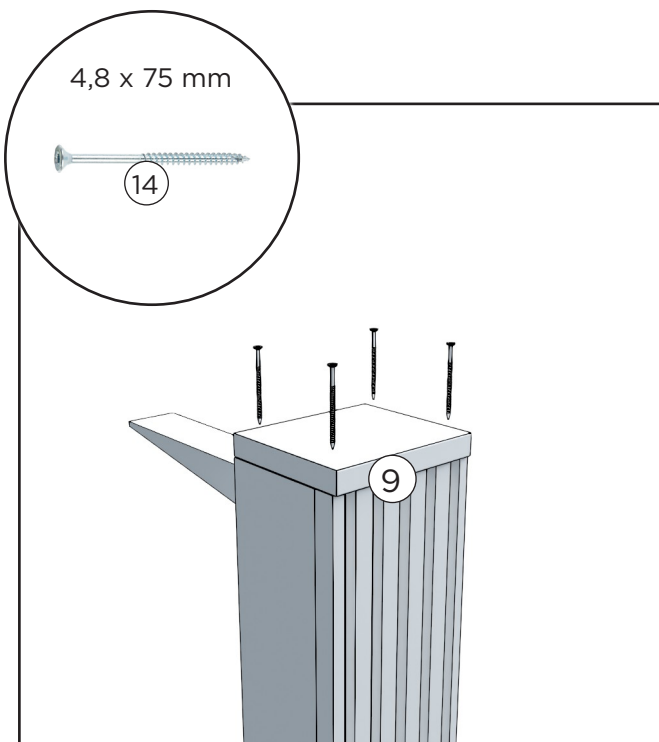

Pillar model: Attach the end to the outdoor shower with four screws.

Outdoor shower (outdoor model): Attach the protective plate to the end of the outdoor shower with four screws.

Note: No protective plate is attached to the terrace model shower.

ATTACHING OUTDOOR SHOWER ON THE TERRACE

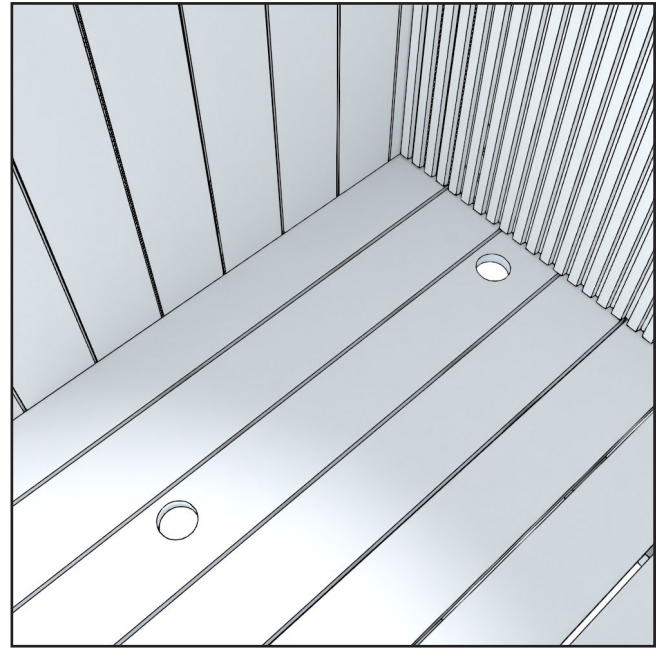
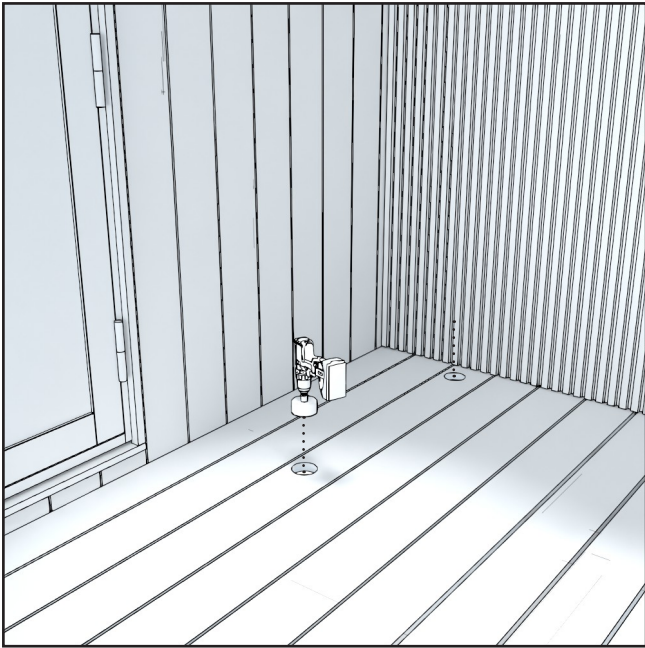

When Kirami FinVision® -outdoor shower Misty is ordered afterwards, holes must be drilled in the terrace module for the water inlet and outlet. The diameter of the hole to be drilled in the terrace is at least 73 mm.

Dimensions to
the left side ins-
tallation:

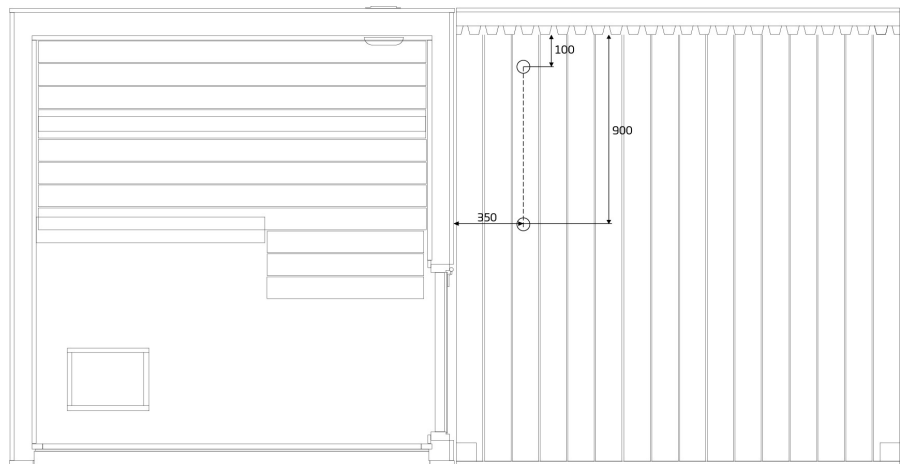

Dimensions to
the right side
installation:

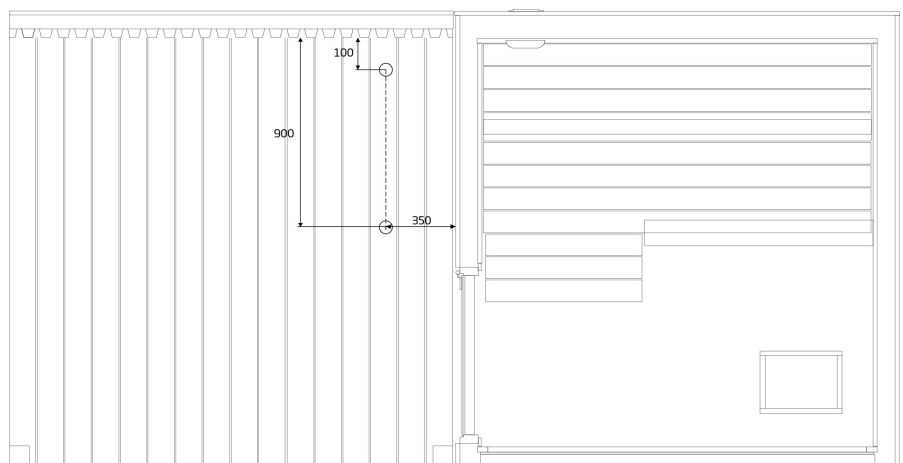

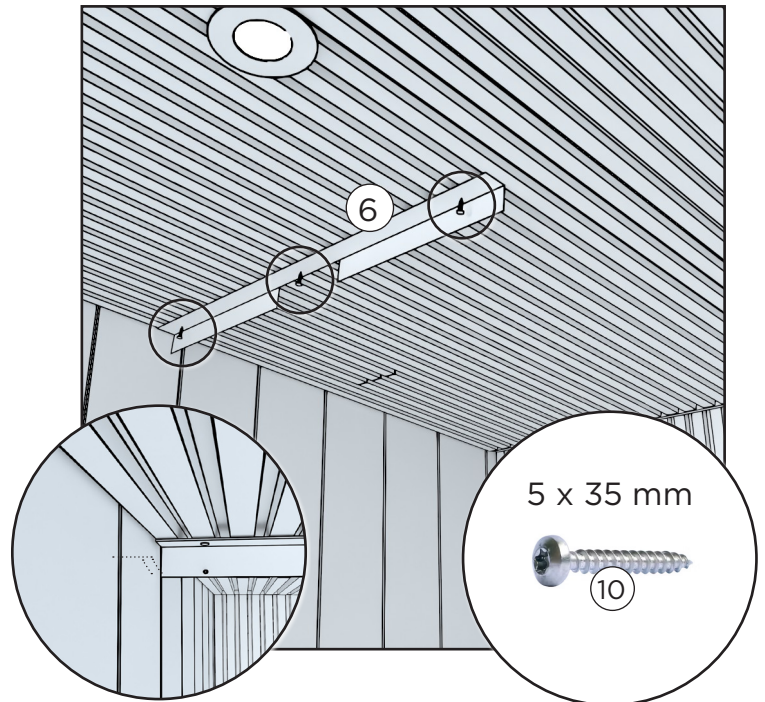
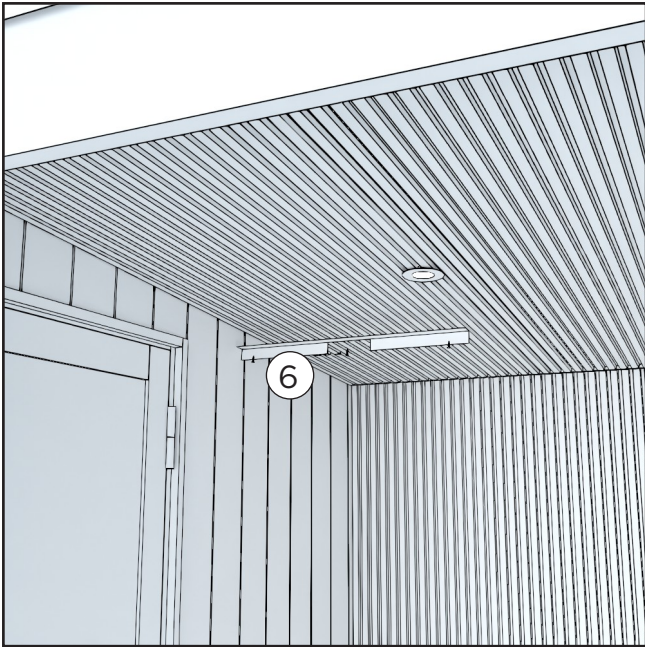

Attach the connection plate between the outdoor shower and the roof to the terrace ceiling, positioning it 830 mm from the back wall and 3-5 mm from the side wall.

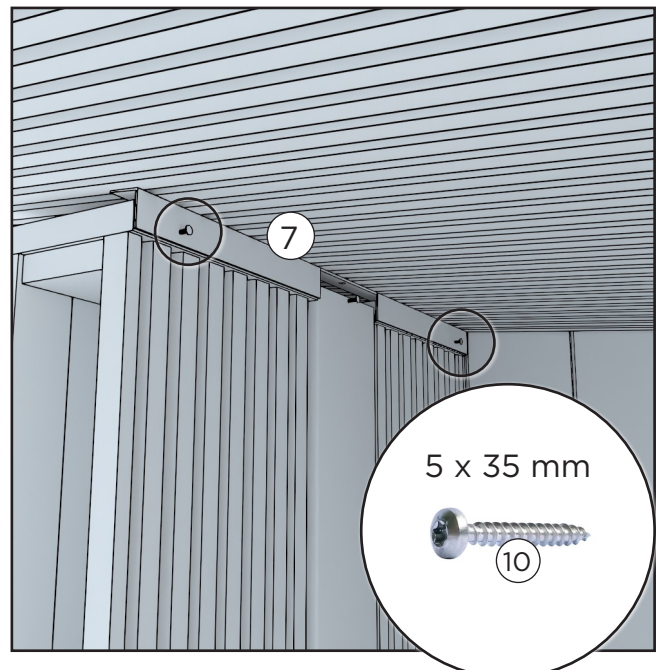
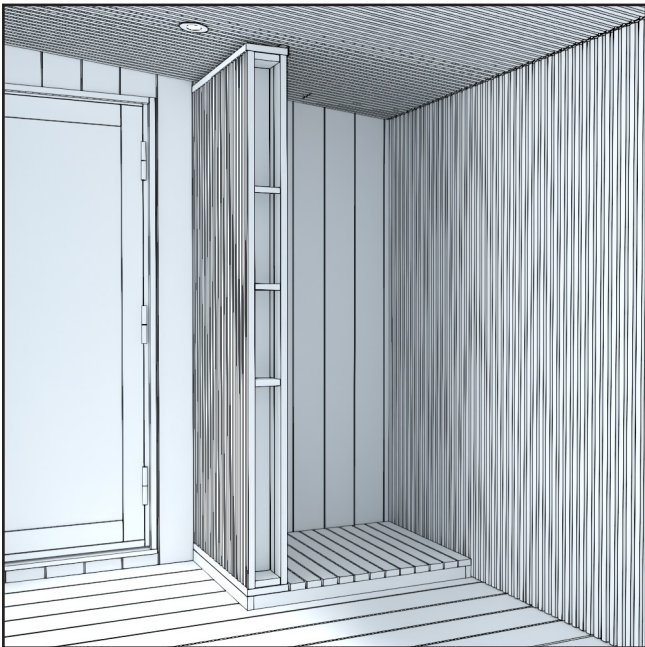

Position the outdoor shower against the connection plate and the back wall of the terrace. Attach the connection plate to the outdoor shower with screws.

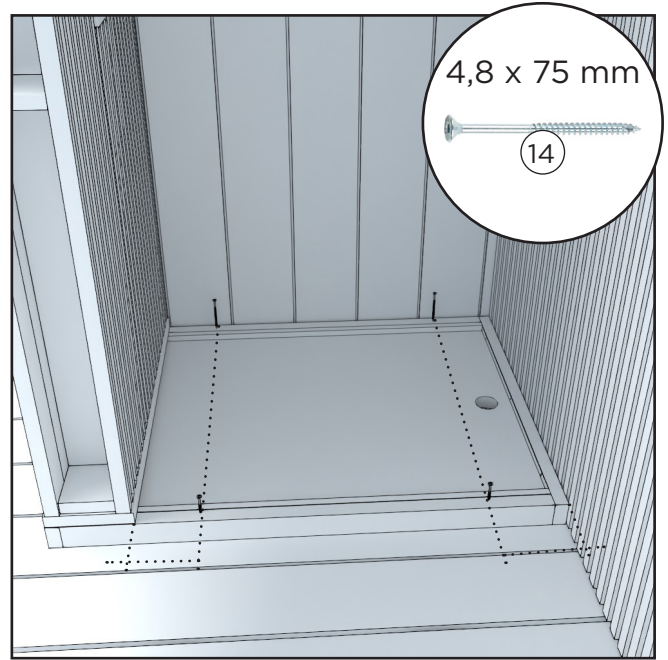
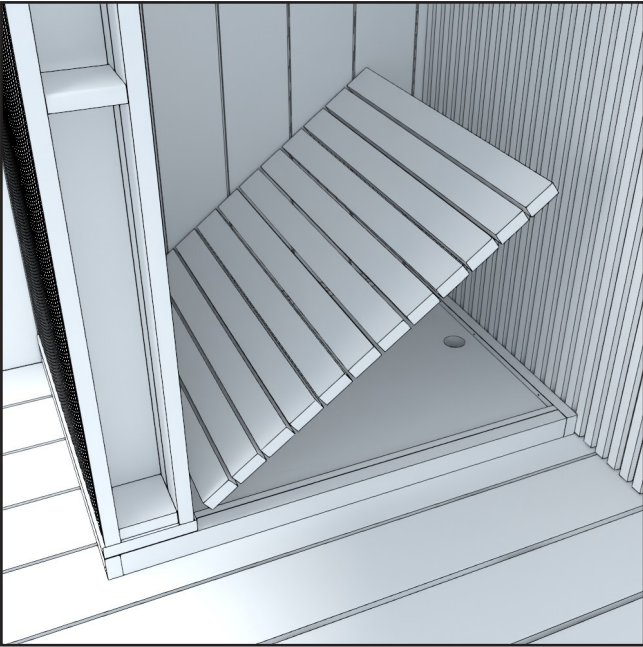

Lift off the grate and screw the base onto the terrace deck. Put the base grate back in place.

ATTACHING OTHER MODELS

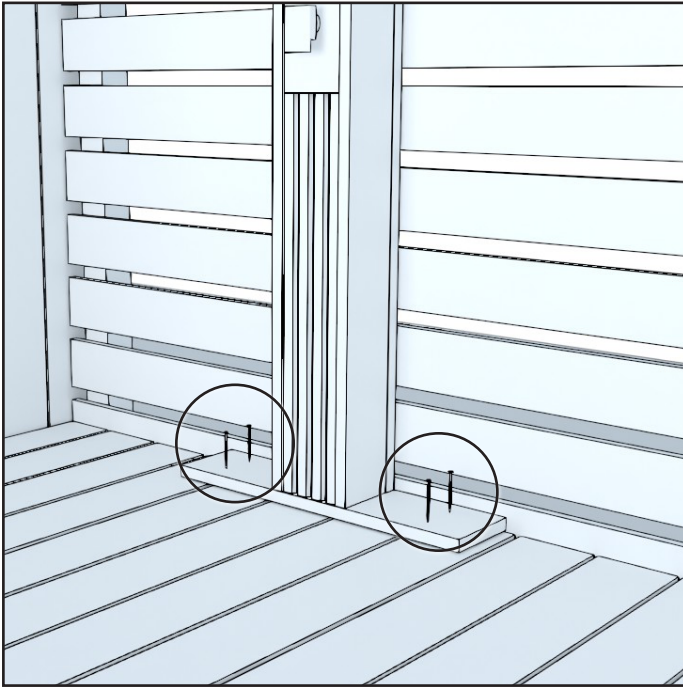

For pillar model outdoor showers, secure the outdoor shower base to the underlying material with four screws.

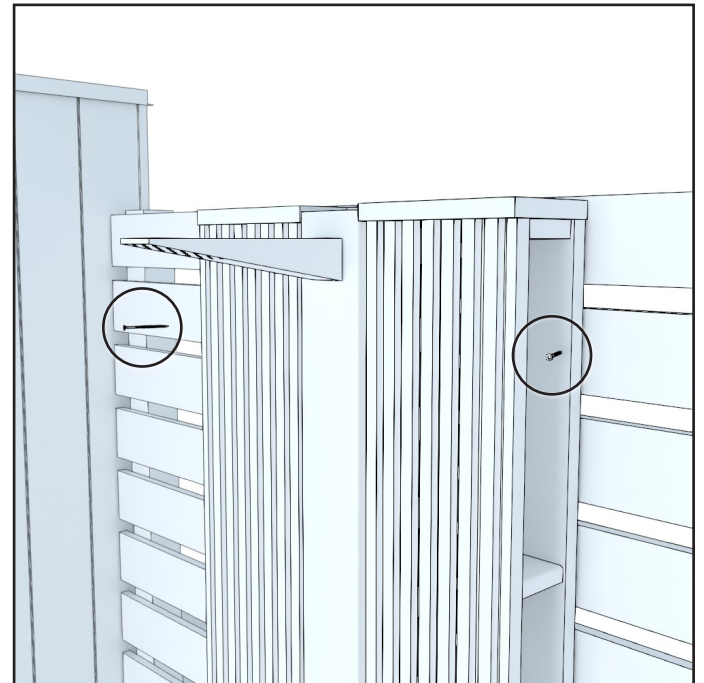
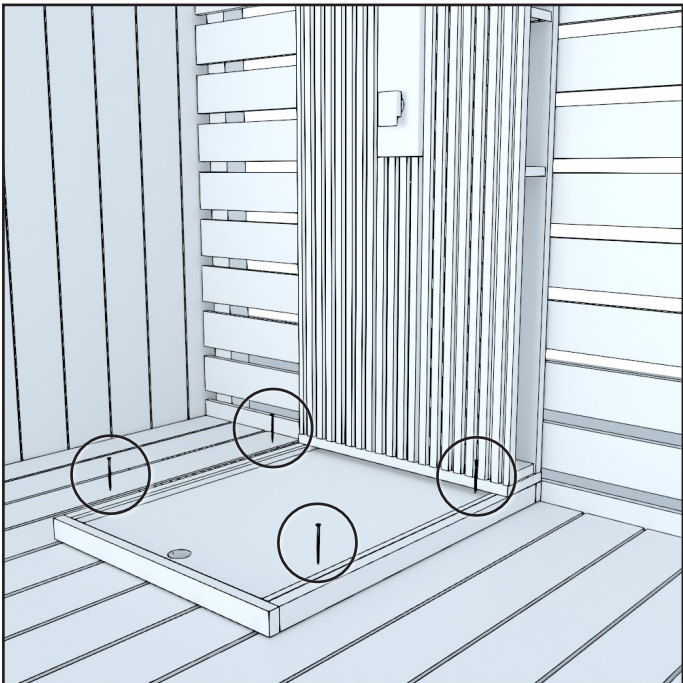

For an outdoor shower with a wall, first secure the base to the underlying material with four screws. Then, attach the top of the wall to the opposing material on both sides with screws.

INLET WATER CONNECTION

The shower is equipped with pre-assembled connections, which can be connected to both hot and cold water pipes or, alternatively, to a garden hose.

CONNECTION WITH THE GARDEN HOSE

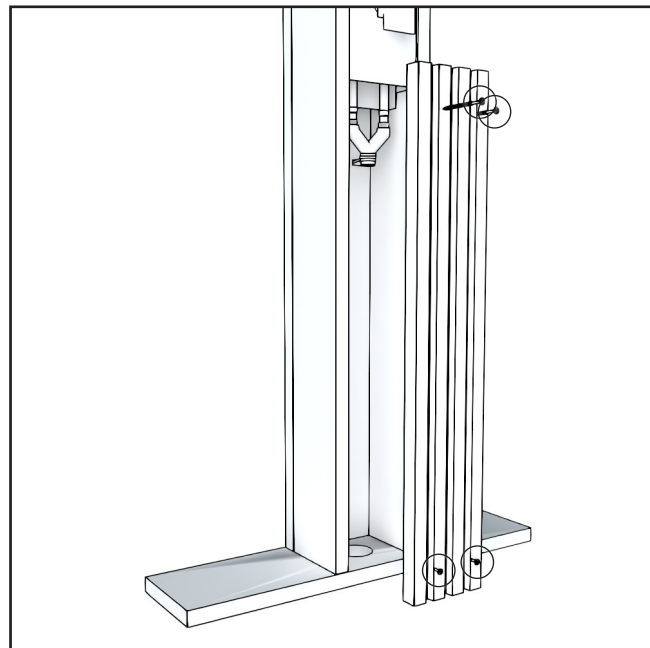
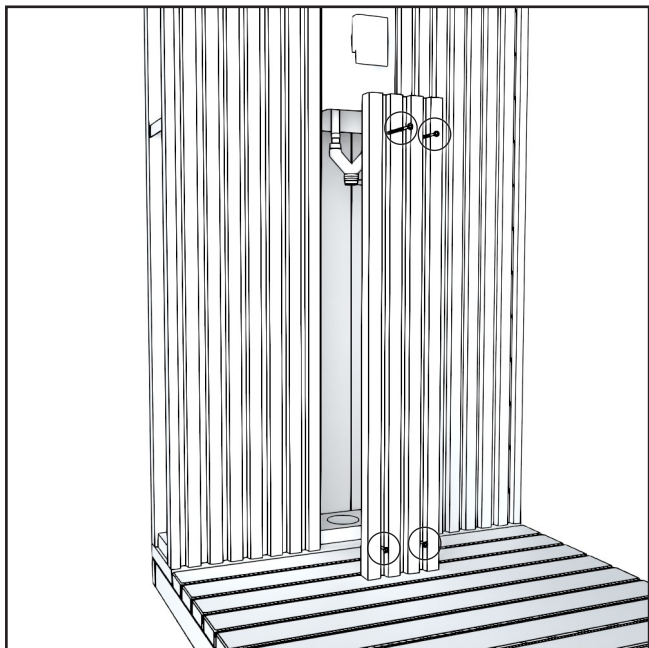

1. The inlet water connectors are located beneath the front panels. Remove the panels.

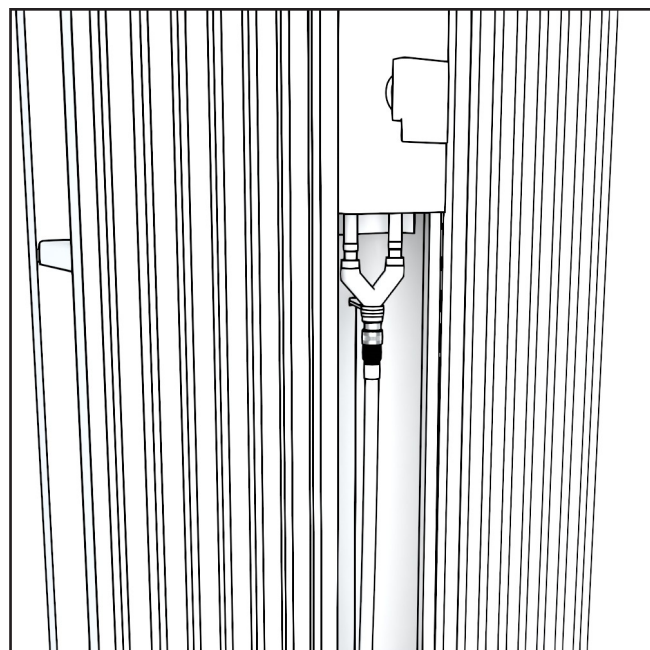

2. Thread the garden hose through the hole at the bottom of the outdoor shower and into the wall, then connect it to the shower.

Once the hose is connected, reattach the two panels.

CONNECTION WITH THE HOT AND COLD WATER

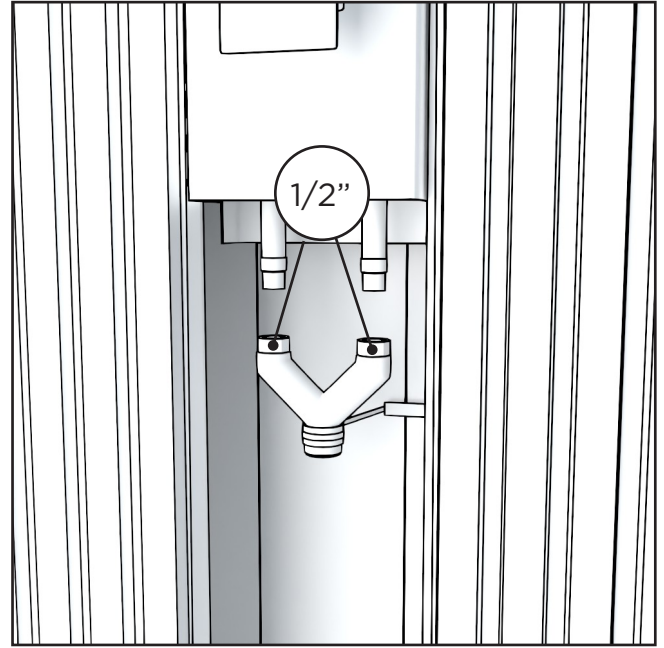
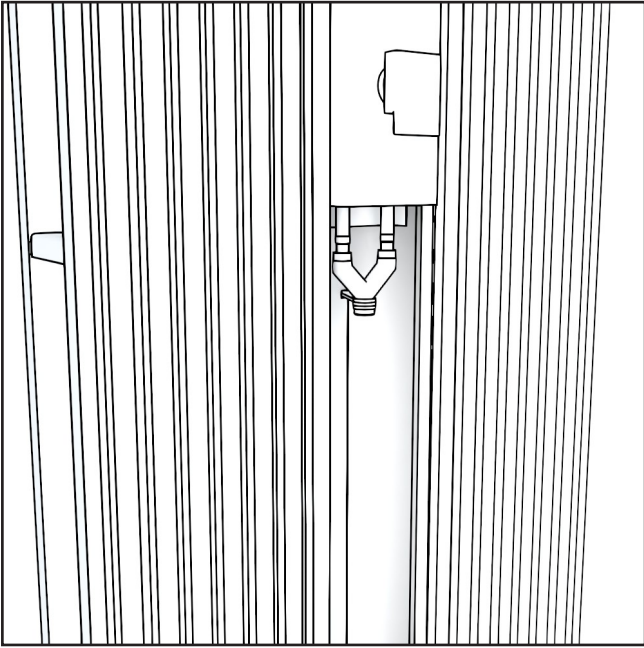

1. Remove the brass pipe splitter by turning the nuts counterclockwise and detaching the bracket from the wall.

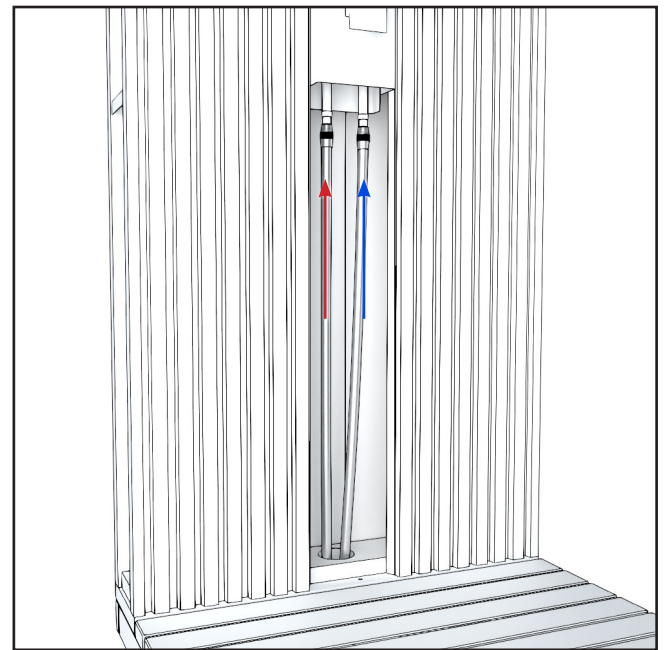
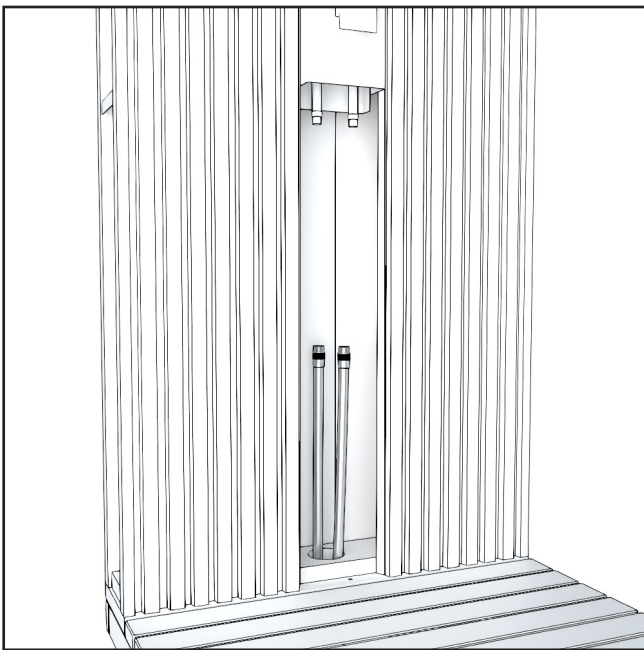

2. Thread the garden hose/pipes into the wall through the hole you drilled in the terrace and the hole below the outdoor shower. Attach hot water to the left side and cold to the right side.

When the hoses/pipes are connected, screw the two panels back.

CONNECTING THE WATER DRAINAGE

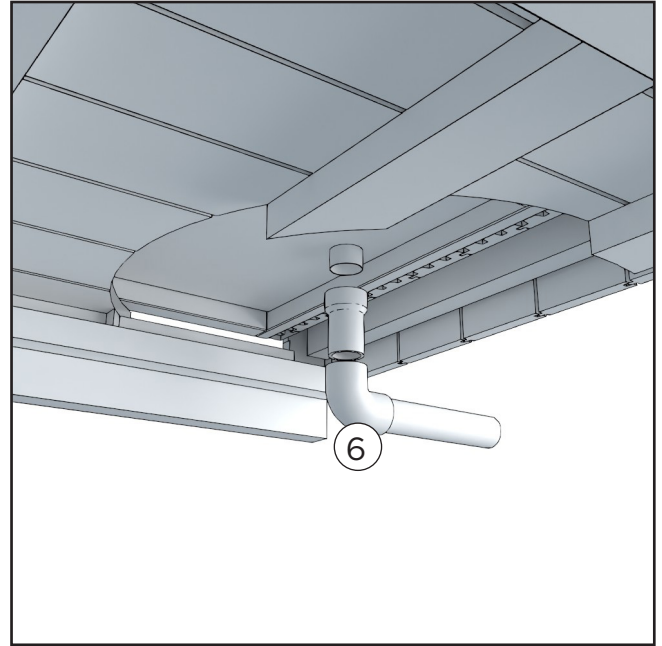
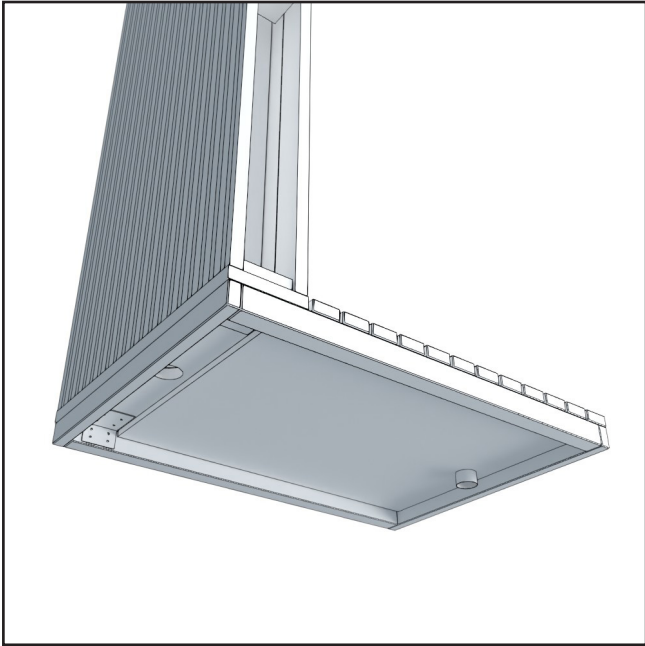

The base has a pre-made 50 mm drainage outlet for wastewater. When installing the Ki-rami FinVision® terrace, connect the pipe parts in the order shown in the image to route the outdoor shower drainage to the back of the module.

ATTACHING THE SHELVES

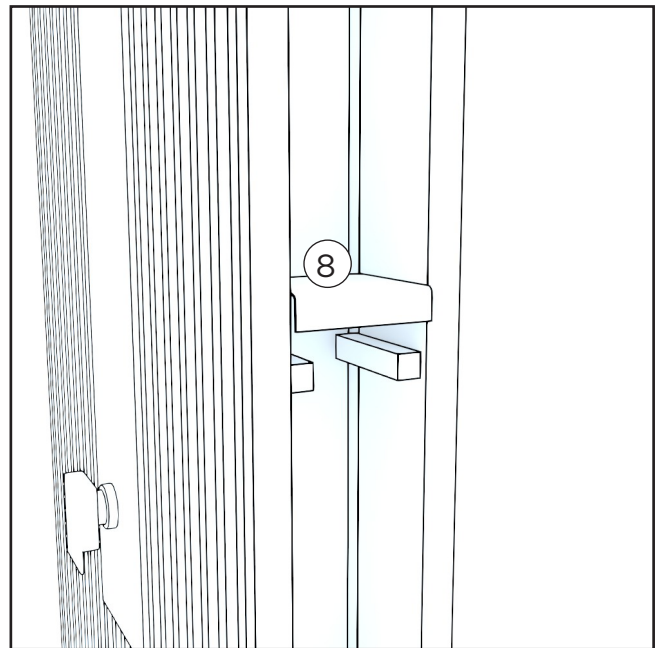
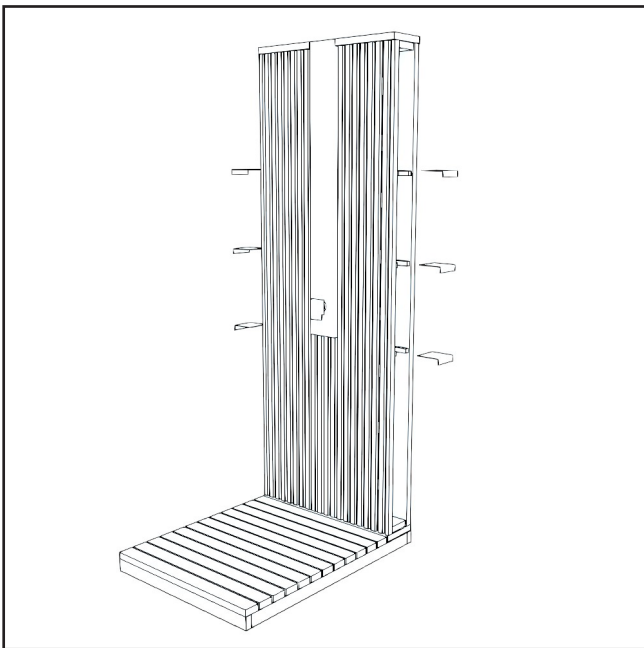

In outdoor showers with a shower wall, there are shelf brackets on the sides. Place the shelves onto the brackets.

WARRANTY

We give our sauna a warranty of 24 months concerning material and manufacturing defects.

The warranty is valid when the user has studied the product's instruction manual and complies with it.

NOTE! An exception to the above is the warranty period of 6 months given to products used for commercial purposes.

- The warranty does not cover any defects typical to wood materials that may occur. E.g. colour changes, changes in humidity, cracks forming, and similar issues.
- The warranty does not cover wear and tear due to normal use.
- The warranty does not cover damage due to user error, for example.
- The warranty does not cover frost damage, either, because it can be avoided with correct use.
- The warranty does not cover any corrosion due to the use of wrong cleaning agents.
- The warranty does not cover any indirect costs, such as building or demolishing a terrace.
- Contact the seller of the product immediately regarding issues with warranties. Attempting to repair the product yourself voids the warranty.

DISPOSING OF THE PRODUCT

The metal parts of the product should be taken to metal recycling, while the wooden parts can be burned, and the glass can be taken to a glass recycling point. The other parts should be disposed of with mixed waste. In Finland, used LED lights can be returned for free and without an obligation to buy a new product to shops where lamps are a part of the usual selection, or alternatively they can be taken to a recycling point.

Kirami FinVision® -outdoor shower XL Misty



Gebrauchsanweisung

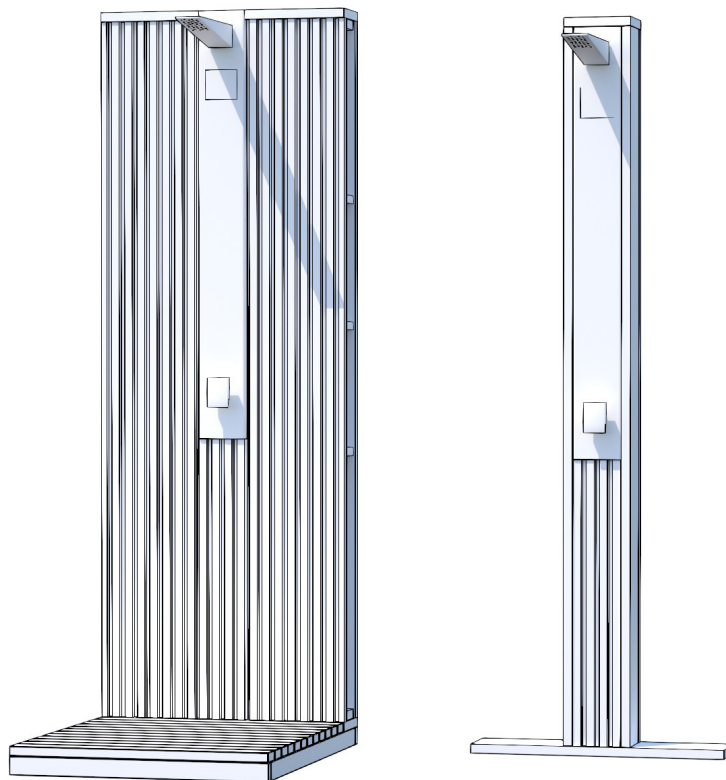

Prüfen Sie unverzüglich den Inhalt der Lieferung!
Lesen Sie die Gebrauchsanweisung sorgfältig durch und
bewahren Sie sie für die Zukunft auf.

ALLGEMEINES

Wenn Sie die Dusche zusammen mit der Terrasse bestellen, ist das Außenduschemodul bereits auf der Terrasse vormontiert. Die Duschwand kann auch nachträglich montiert werden, in diesem Fall wird sie in Einzelteilen geliefert.

Die hochwertigen, aus Edelstahl gefertigten Duscharmaturen sind an der Duschwand vorinstalliert. Die Dusche wird mit vorbereiteten Wasseranschlüssen geliefert, die sowohl an die Warm- als auch an die Kaltwasserleitung oder alternativ an einen Gartenschlauch angeschlossen werden können.

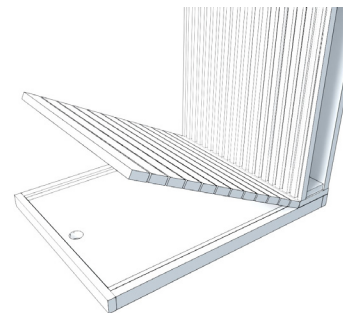

Der Bodenrost der bodengleichen Dusche ist herausnehmbar. Unter dem Gitterrost befindet sich eine Rinne aus verzinktem Blech, die das Waschwasser in das Abflussrohr leitet.

ÜBERPRÜFUNG DER LIEFERUNG

Wir empfehlen Ihnen, vor der Unterzeichnung des Frachtbriefs stets zu überprüfen, ob Sie eine unversehrte Palette erhalten haben. Wenn Sie später feststellen, dass etwas aus dem Inhalt fehlt, wenden Sie sich bitte an die Partei, die das Produkt geliefert hat.



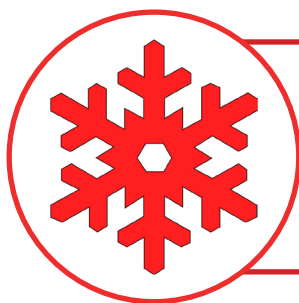







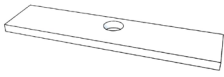

Wenn Sie die Außendusche gleichzeitig mit den anderen Modulen bestellt haben, können Sie zu den Abschnitten "ANSCHLUSS DES WASSERZULAUFES" und "ANSCHLUSS DES Wasserabflusses" springen.

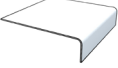
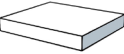

HINWEIS: Im Winter muss das Wasser aus der Außendusche abgelassen werden, um Frostschäden zu vermeiden.

Öffnen Sie den Hahn und blasen Sie Luft durch das System.

TEILELISTE

Nro	Kuva	Nimi	Pilari (Ilman alustaa)	Pilari (Alustalla)	Suihkuseinä (Terassimalli)	Suihkuseinä (Ulkomalli)
1.		Boden			1	1
2.		Bodenplanke für eine Säule	1	1		
3.		Wand			1	1
4.		Säule	1	1		
5.		Duschkopf (mit Unterlegscheibe und Mutter)	1	1	1	1
6.		Abflussrohr		1	1	1
7.		Verbindungs- platte zur Decke			1	
8.		Ablage			6	6
9.		Schutz - Säule	1	1		
10.		Schutzplatte				1
11.		Schraube 5x35 mm			8	
12.		Schraube 4,2 x 19 mm		10	10	10
13.		Schraube 4,8x25				4
14.		Schraube 4,8 x 75 mm	12	12	4	6

PLATZIERUNG

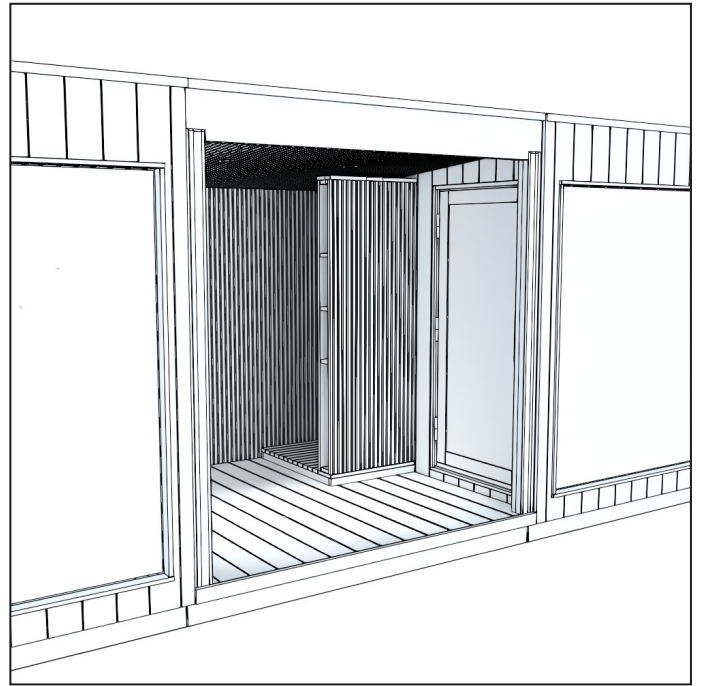
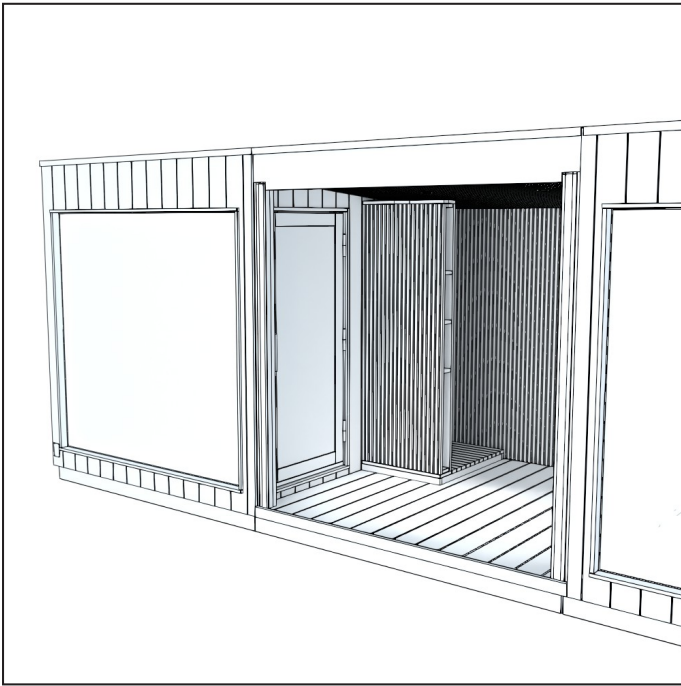

Die Kirami FinVision® Misty Außendusche (Terrassenmodell) wird immer auf der Kirami FinVision® Terrasse montiert, entweder am linken oder rechten Rand, so dass eine Seite der Außendusche an einem anderen Modul anliegt.

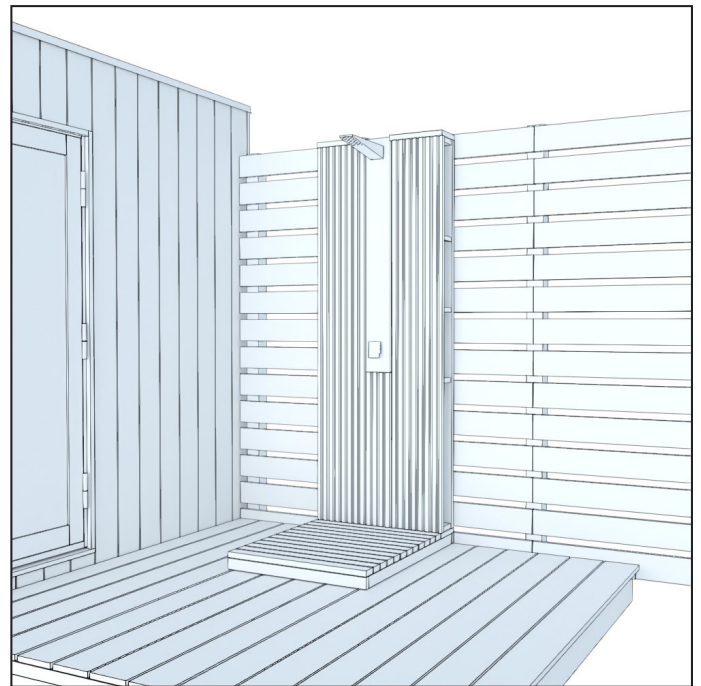
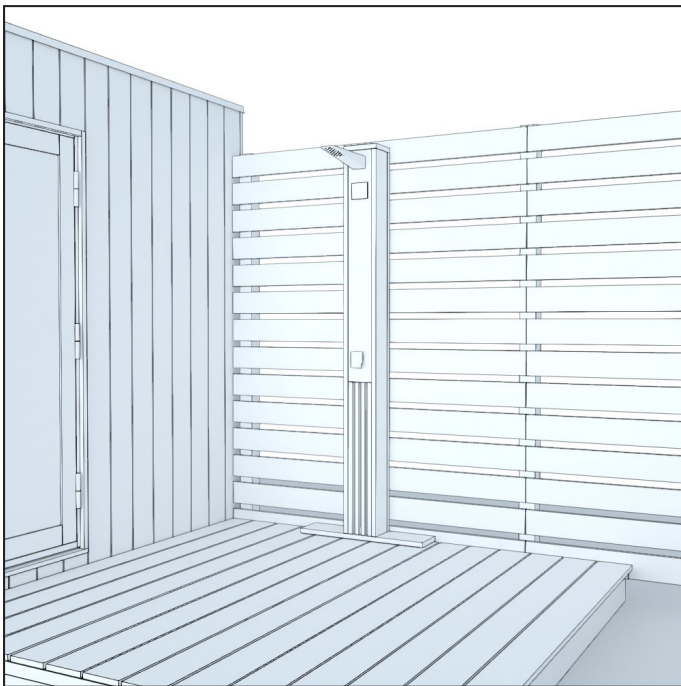

Die Kirami FinVision® -Außendusche (Modell für abseits der Terrasse) und die Säulenmodelle können auf jeder ebenen Fläche montiert werden, z. B. auf einer Außen- oder Dachterrasse, in der Nähe eines Hot Tubs, Swimmingpools oder einer Sauna.

Es wird immer empfohlen, Außenduschen an einer Wand oder einer anderen stabilen Struktur zu montieren.

MONTAGE

Säule

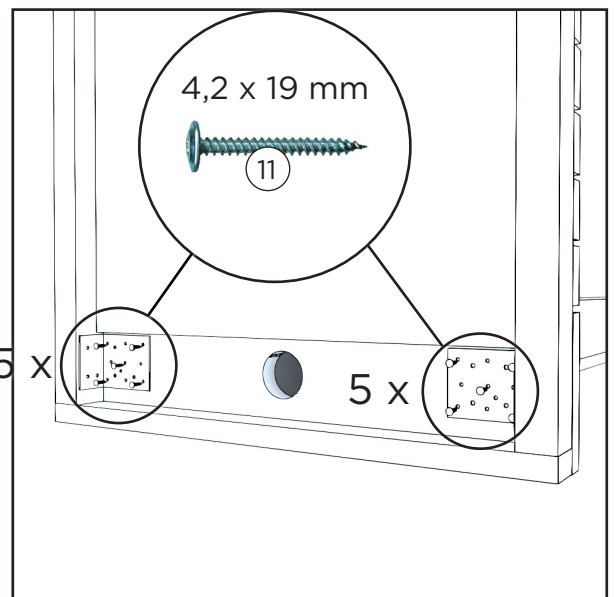
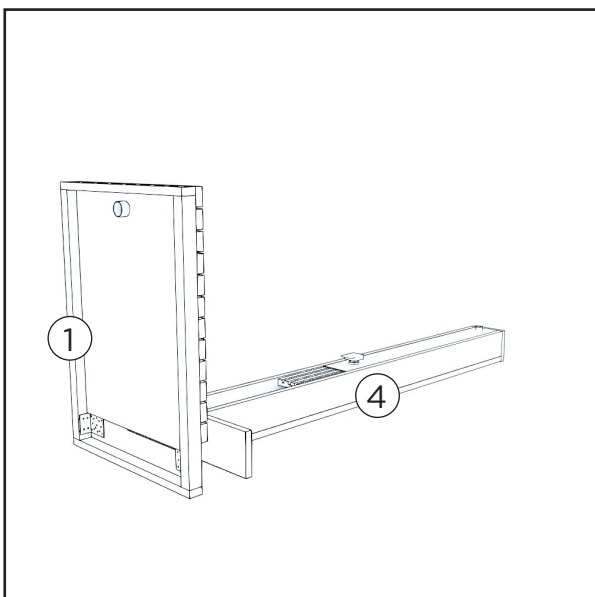
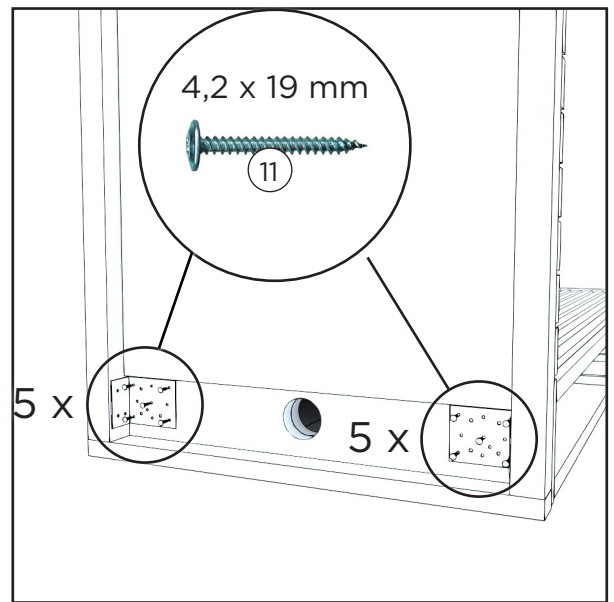
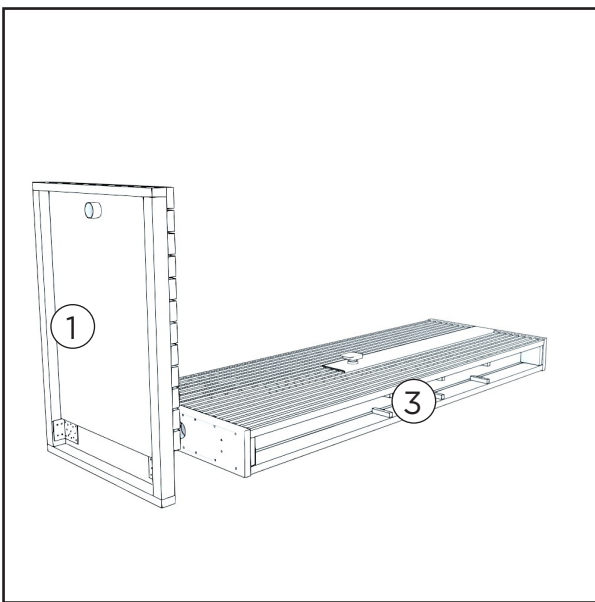
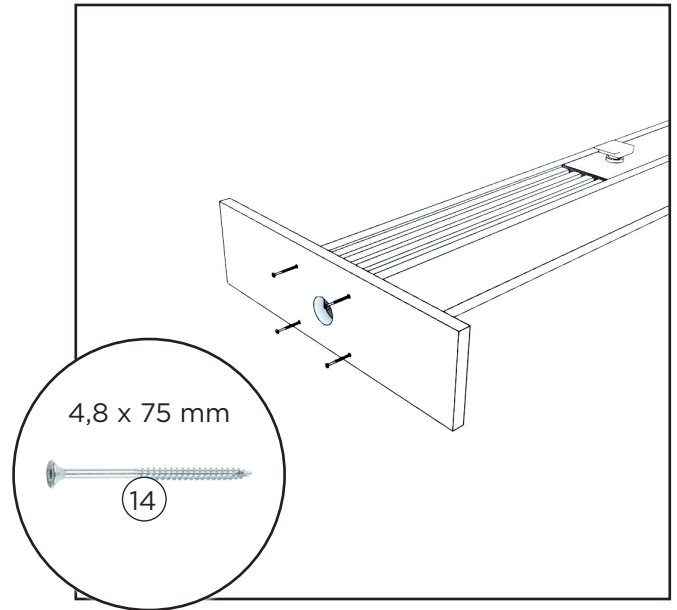
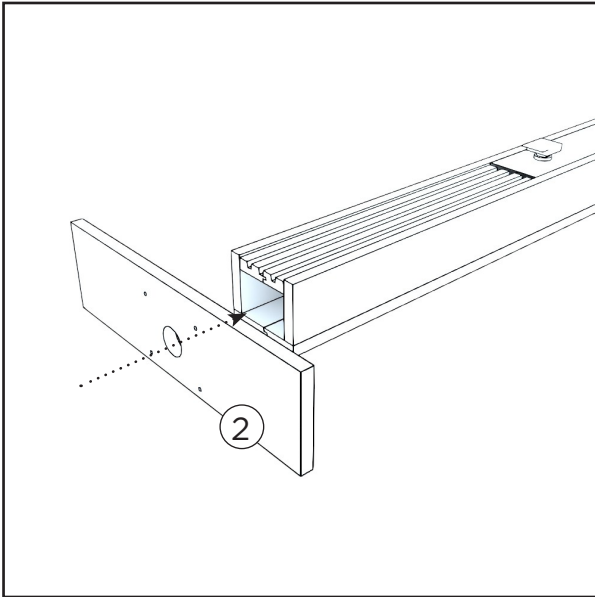

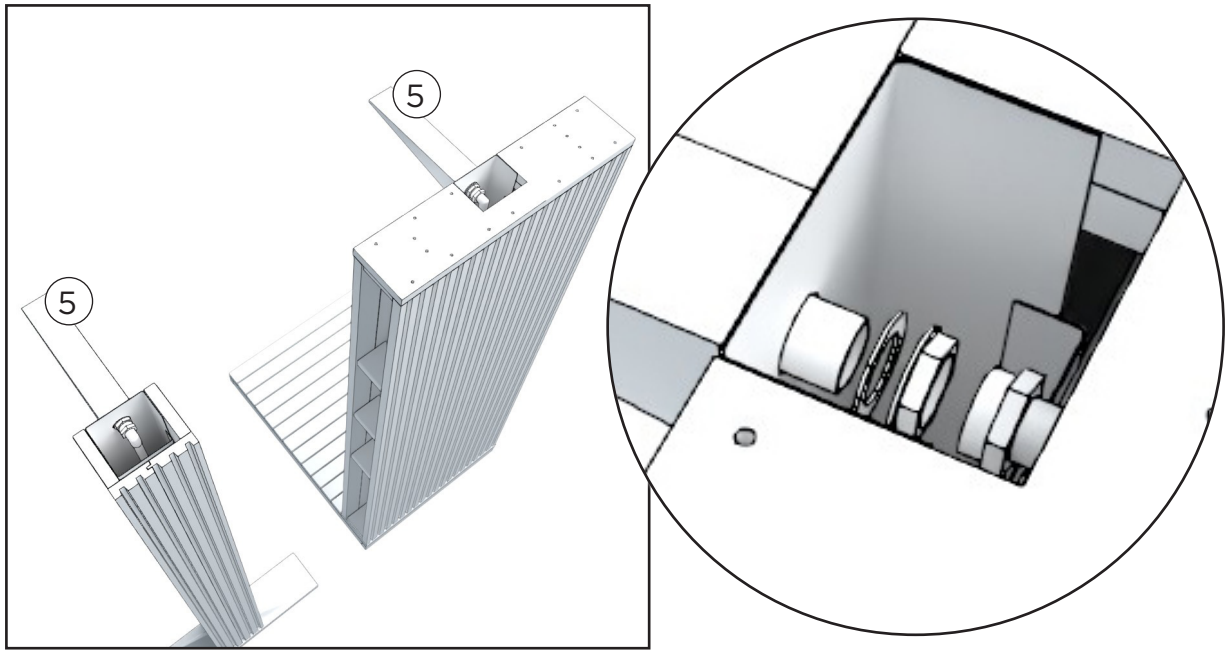

Befestigen Sie zuerst den Duschkopf mit einer Messingmutter an der Edelstahlplatte; beachten Sie, dass eine Unterlegscheibe zwischen der Edelstahlplatte und der Messingmutter angebracht werden sollte. Entfernen Sie das Klebeband vom Krümmen in der Dusche und schließen Sie ihn an den Duschkopf an.

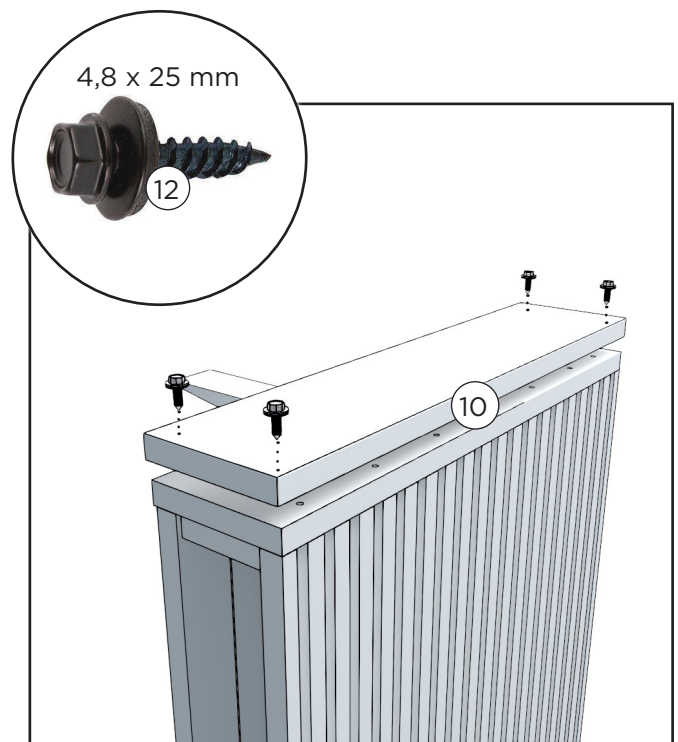
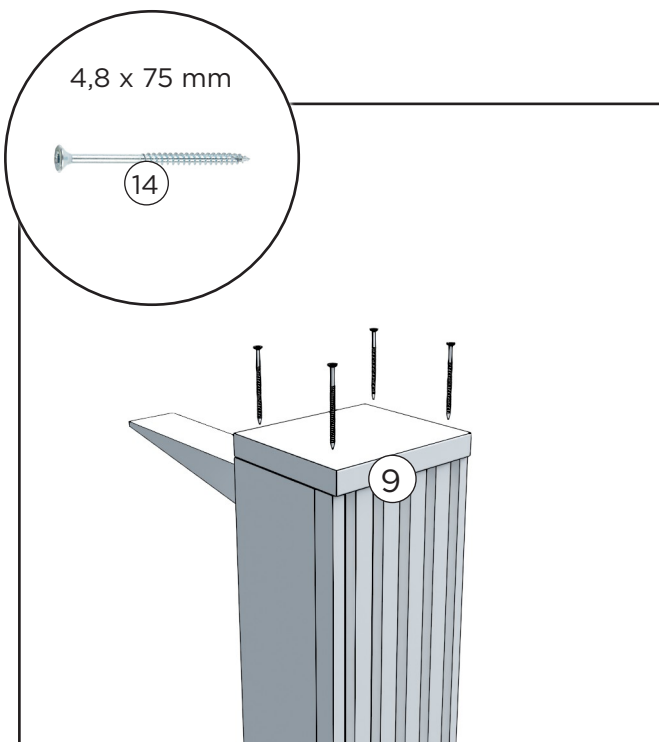

Säulenmodell: Befestigen Sie das Ende mit vier Schrauben an der Außendusche.

Außendusche (Außenmodell): Befestigen Sie die Schutzplatte mit vier Schrauben am Ende der Außendusche.

Hinweis: An der Terrassendusche ist keine Schutzplatte angebracht.

MONTAGE EINER AUSSENDUSCHBE AUF DER TERRASSE

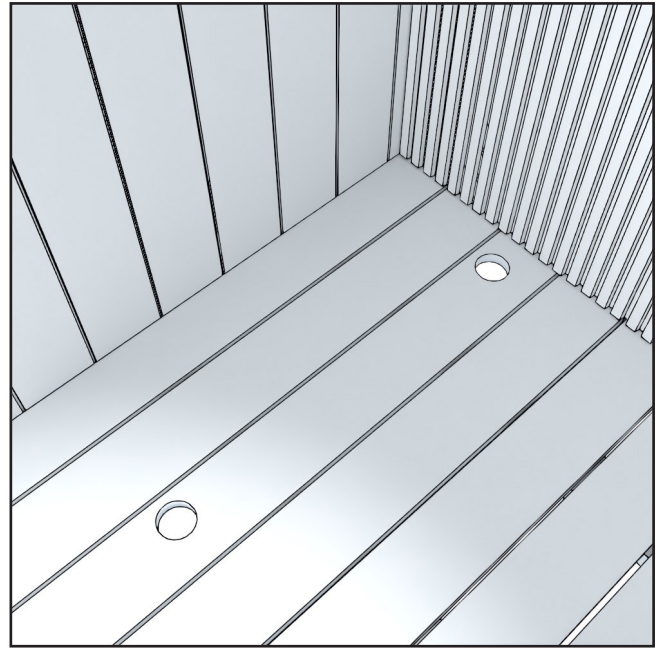
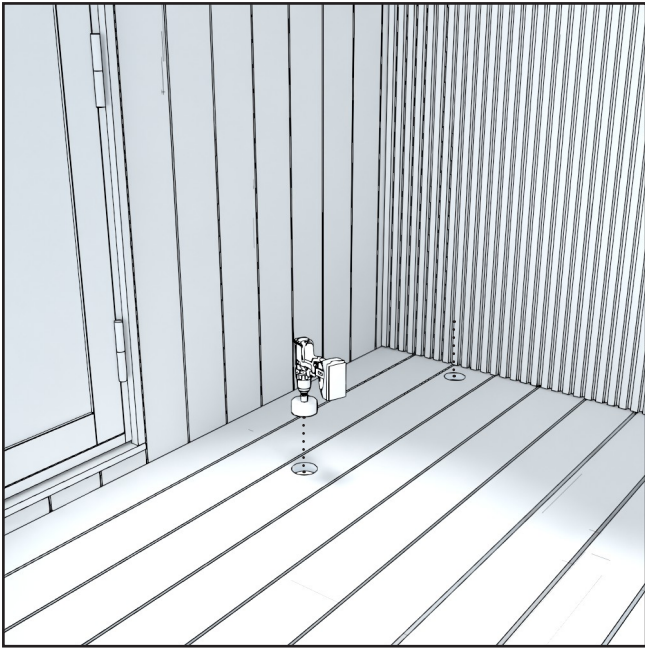

Wenn die Kirami FinVision® -Außendusche Misty nachträglich bestellt wird, müssen im Terrassenmodul Löcher für den Wasserzu- und -ablauf gebohrt werden. Der Durchmesser des in die Terrasse zu bohrenden Lochs beträgt mindestens 73 mm.

Abmessungen
bei einer Montage
auf der linken
Seite:

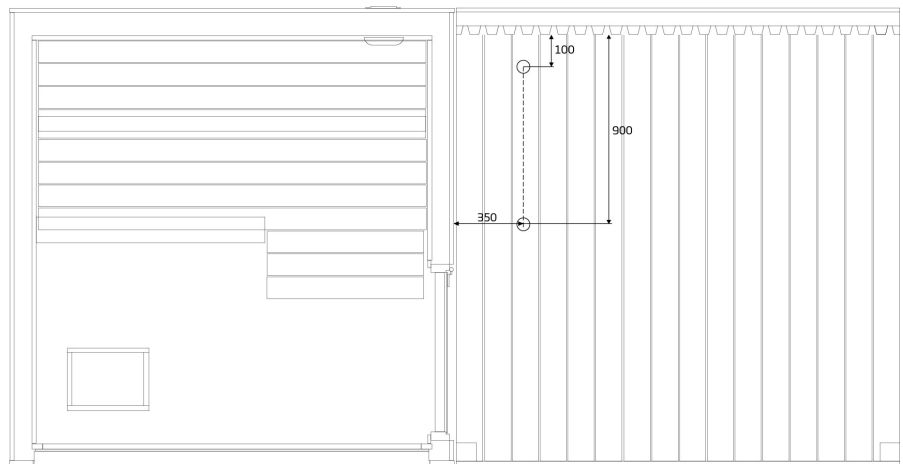

Abmessungen
bei einer Montage
auf der rechten
Seite:

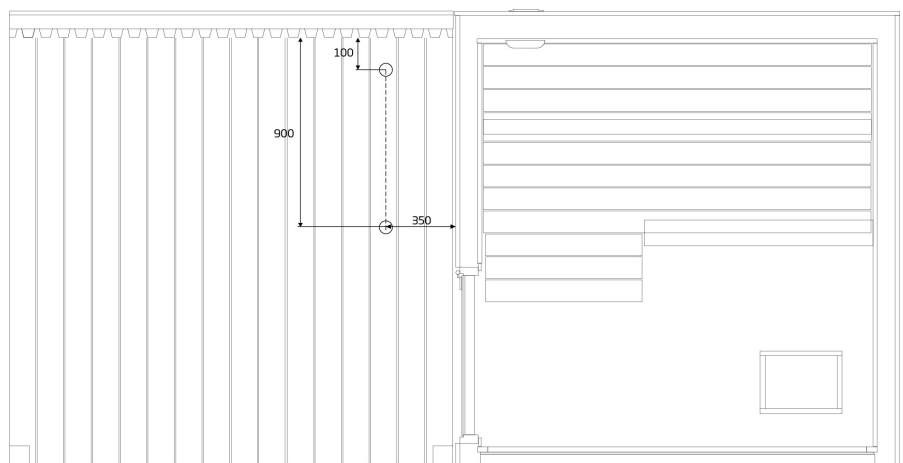

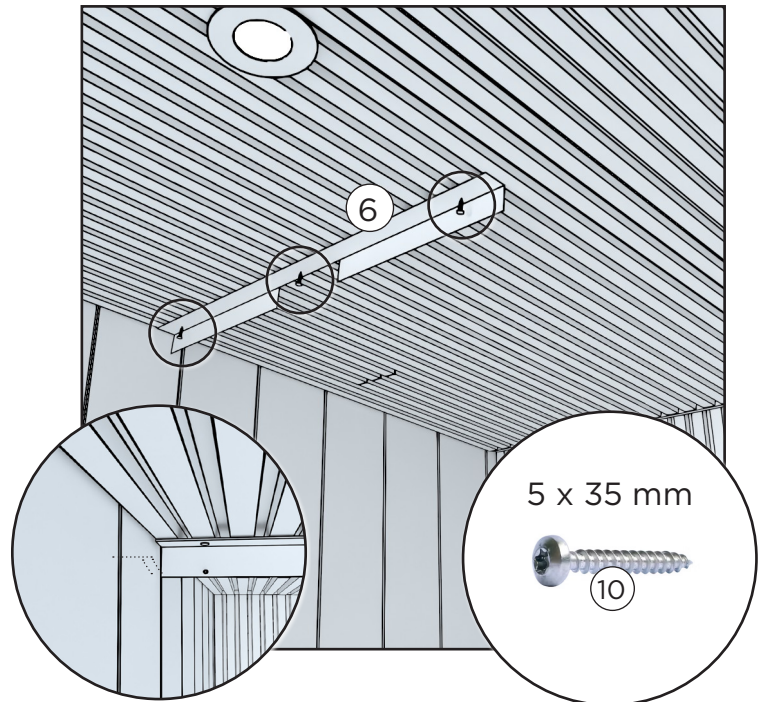
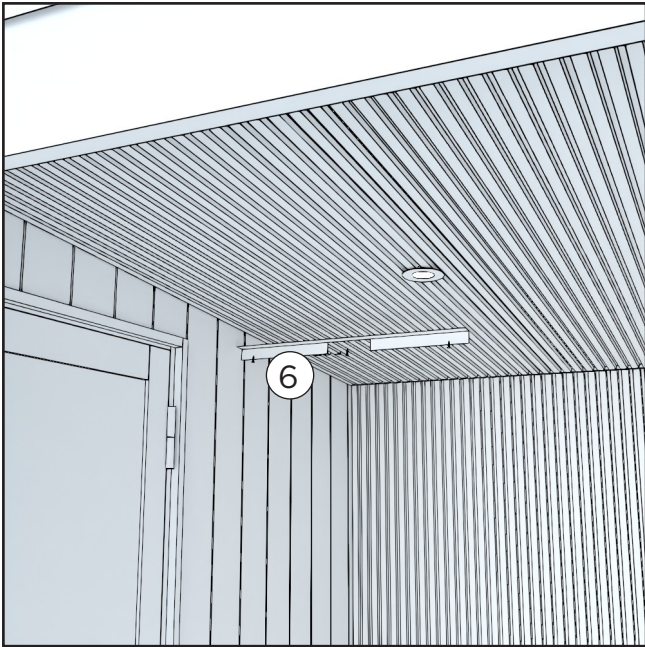

Befestigen Sie die Verbindungsplatte zwischen der Außendusche und dem Dach an der Terrassendecke und positionieren Sie sie 830 mm von der Rückwand und 3-5 mm von der Seitenwand entfernt.

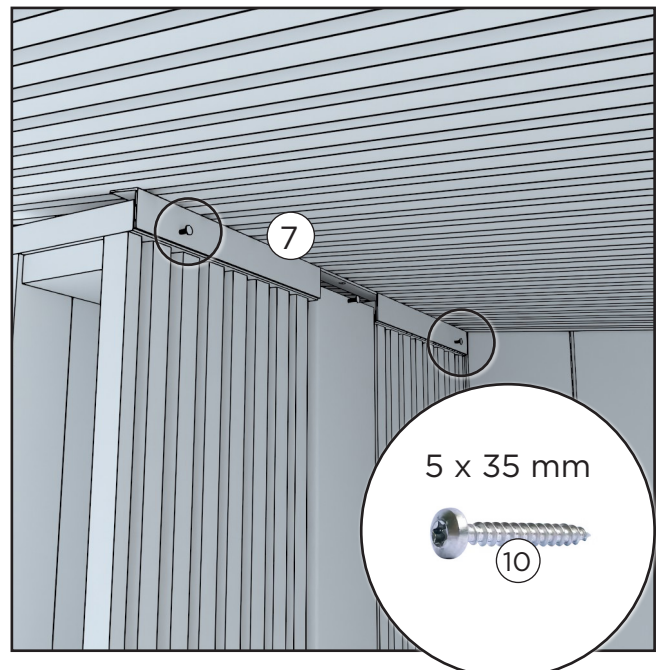
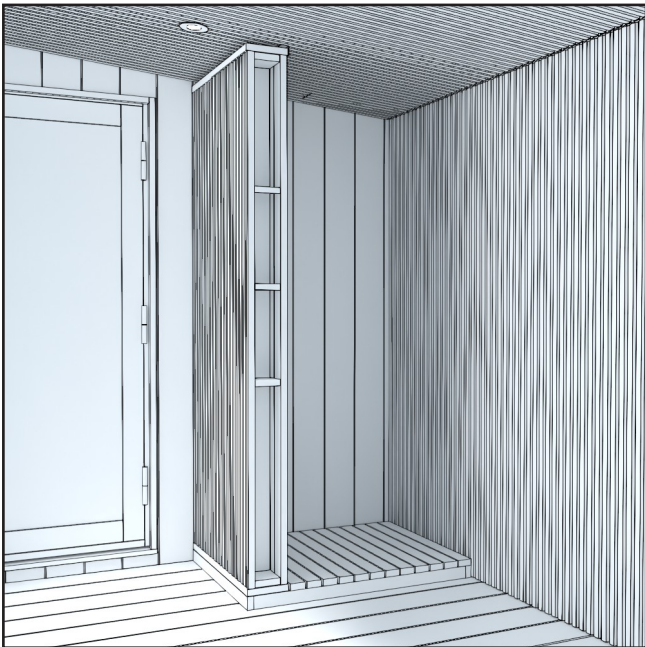

Positionieren Sie die Außendusche gegen die Verbindungsplatte und die Rückwand der Terrasse. Befestigen Sie die Verbindungsplatte mit Schrauben an der Außendusche.

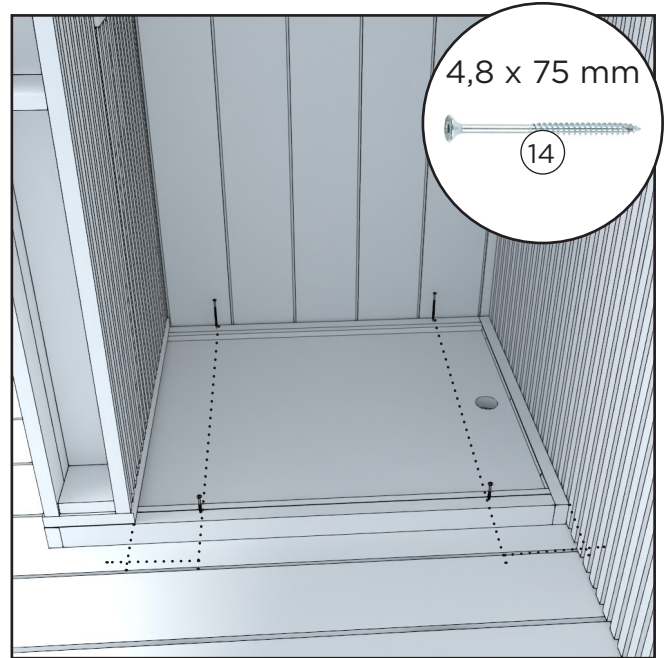
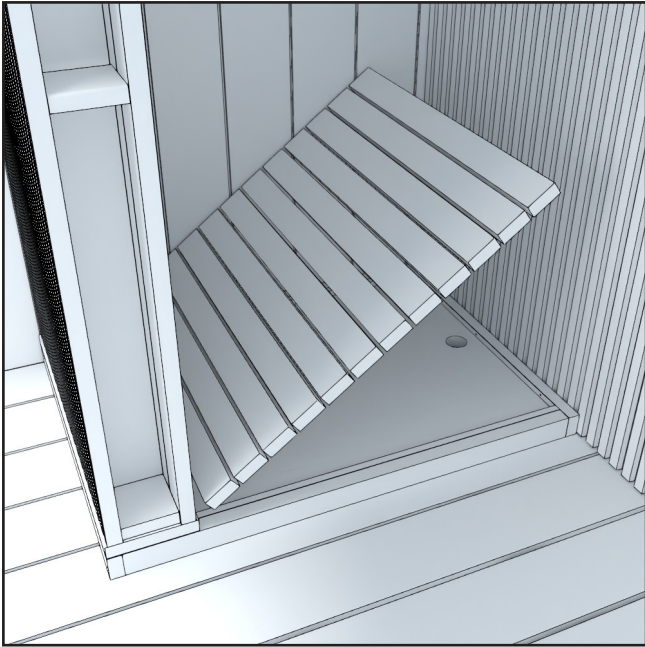

Heben Sie den Rost ab und schrauben Sie den Sockel auf das Terrassendeck. Bringen Sie das Bodengitter wieder an.

VERBINDEN MIT ANDEREN MO- DULEN

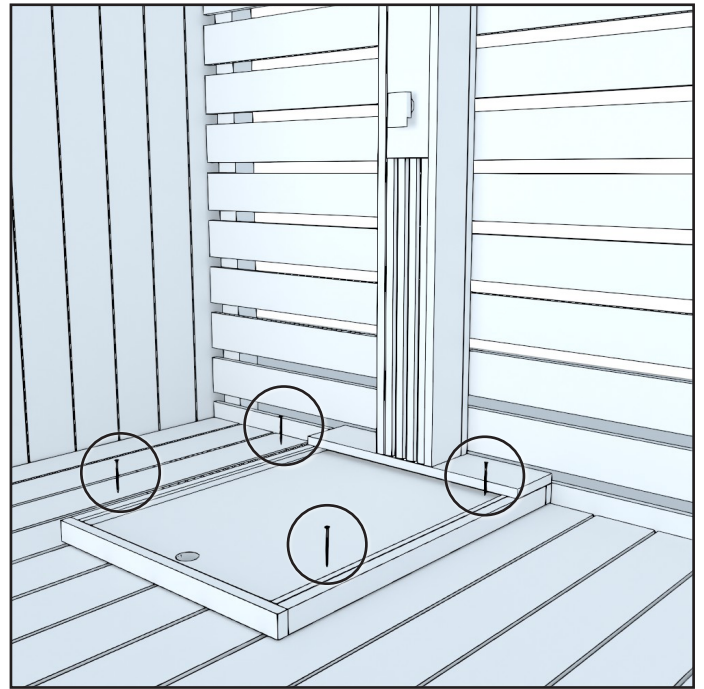
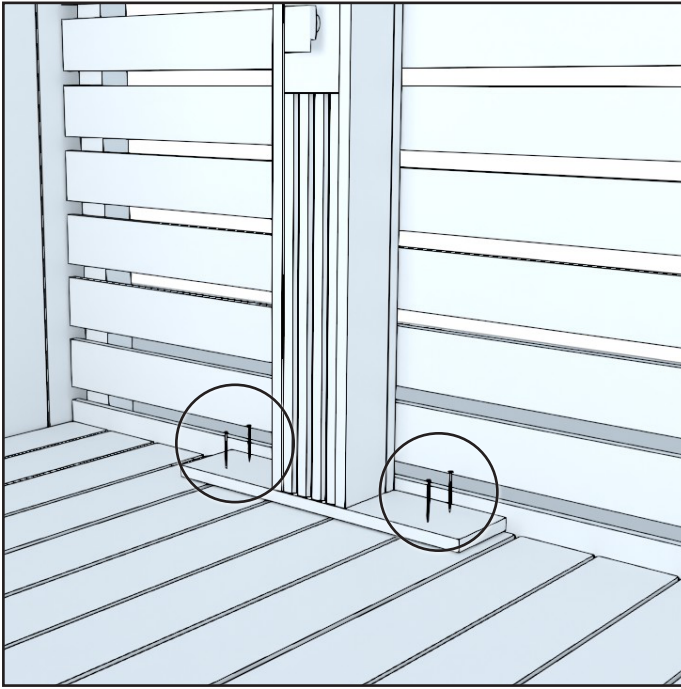

Bei Säulenduschen befestigen Sie die Basis der Außendusche mit vier Schrauben am Untergrund.

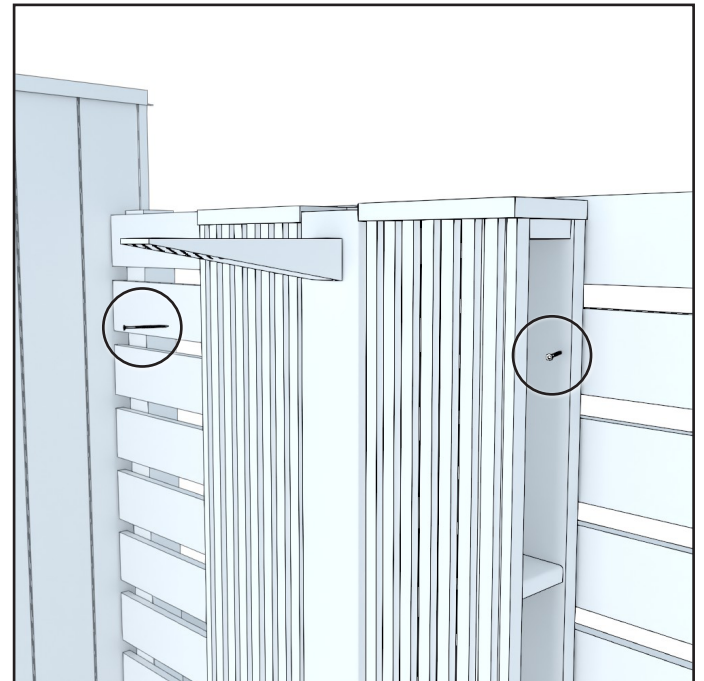
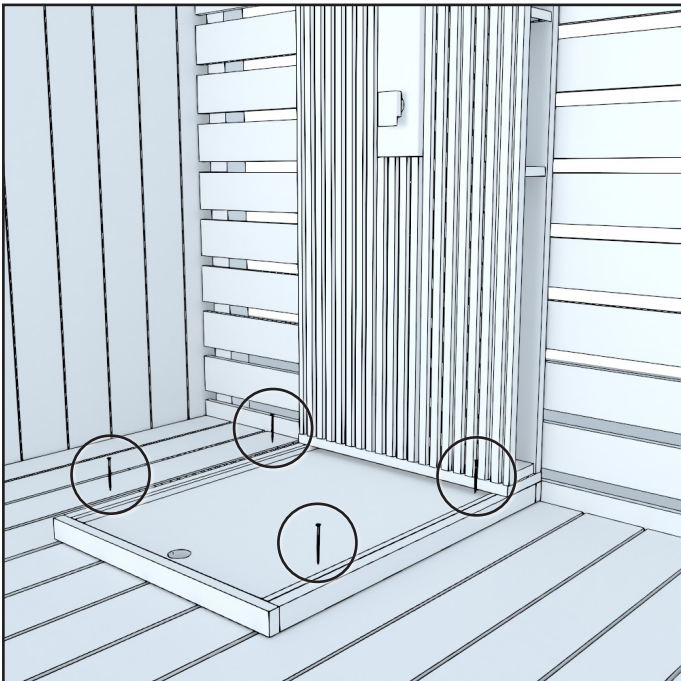

Bei einer Außendusche mit Wand befestigen Sie zunächst die Basis mit vier Schrauben an dem darunter liegenden Material. Befestigen Sie dann den oberen Teil der Wand auf beiden Seiten mit Schrauben an dem angrenzenden Material.

ANSCHLUSS DES WASSERZULAUFES

Die hochwertigen, aus Edelstahl gefertigten Duscharmaturen sind an der Duschwand vorinstalliert. Die Dusche wird mit vorbereiteten Wasseranschlüssen geliefert, die sowohl an die Warm- als auch an die Kaltwasserleitung oder alternativ an einen Gartenschlauch angeschlossen werden können.

ANSCHLUSS AN EINEN GARTENSCHLAUCH

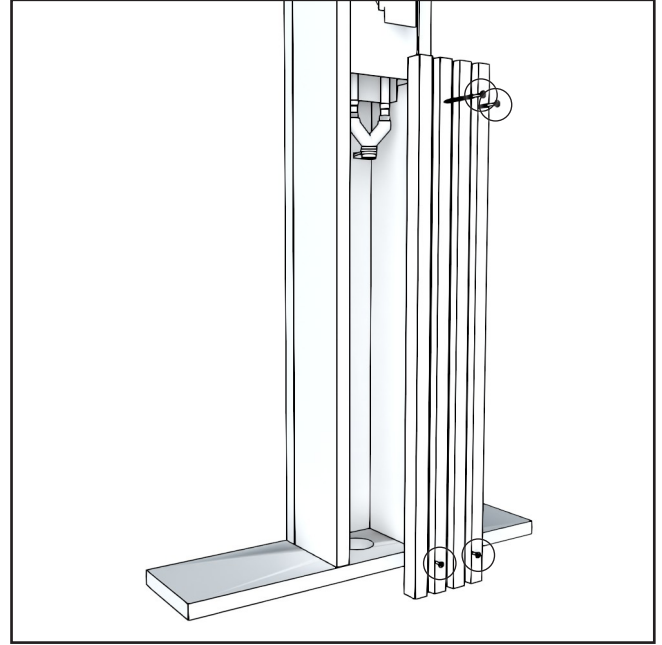
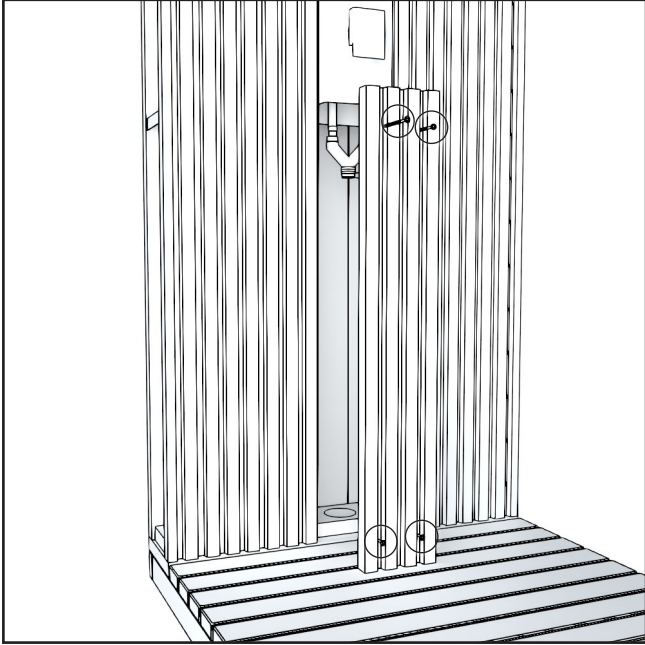

1. Die Wasserzulaufanschlüsse befinden sich unter den Frontpaneelen. Entfernen Sie die Paneele.

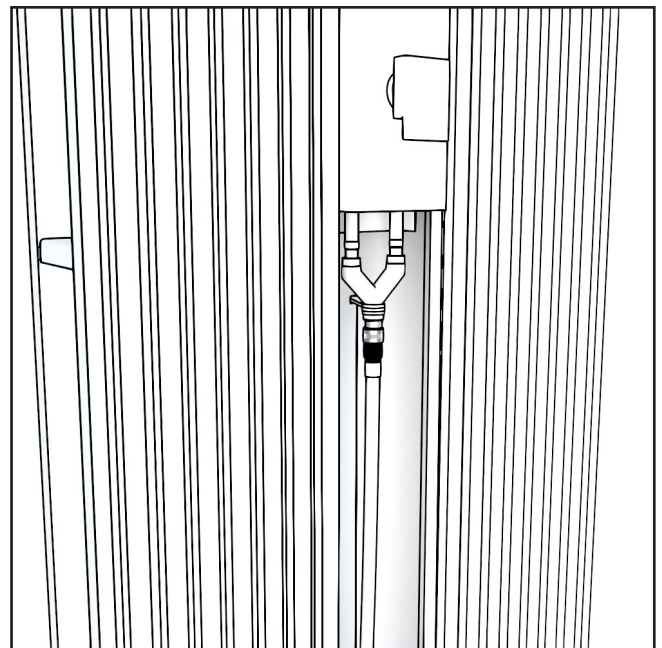

2. Führen Sie den Gartenschlauch durch das Loch an der Unterseite der Außendusche in die Wand und schließen Sie ihn dann an die Dusche an.

Sobald der Schlauch angeschlossen ist, bringen Sie die beiden Paneele wieder an.

ANSCHLUSS AN WARM- UND KALTWASSER

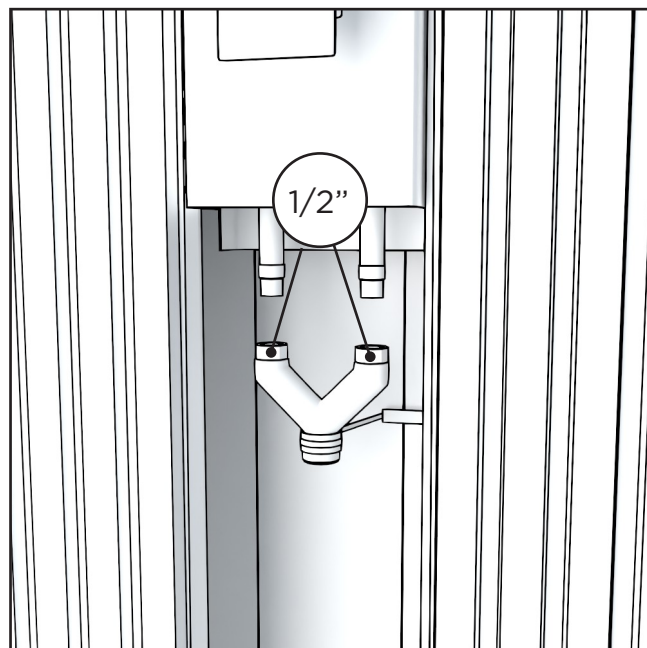
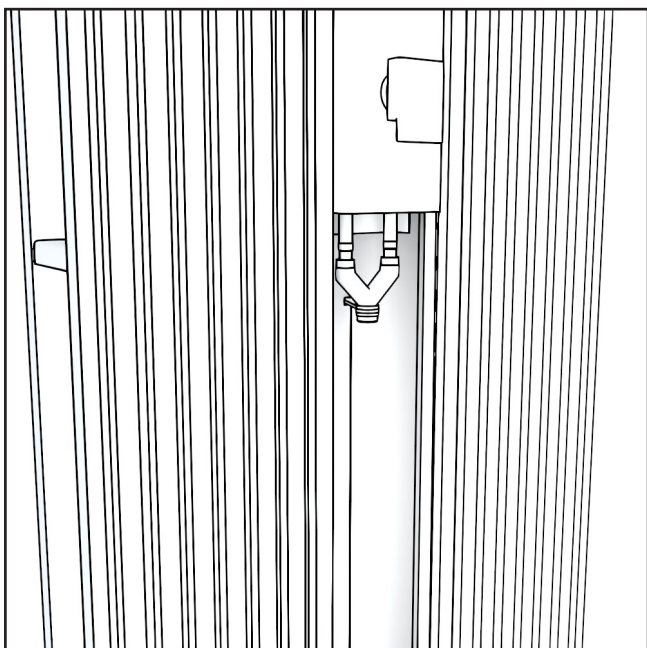

1. Entfernen Sie den Rohrspalter aus Messing, indem Sie die Muttern gegen den Uhrzeigersinn drehen und die Halterung von der Wand lösen.

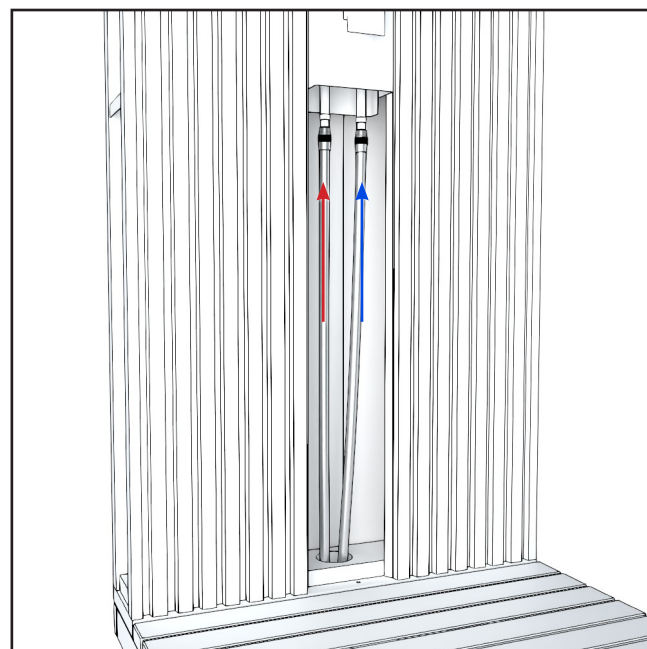
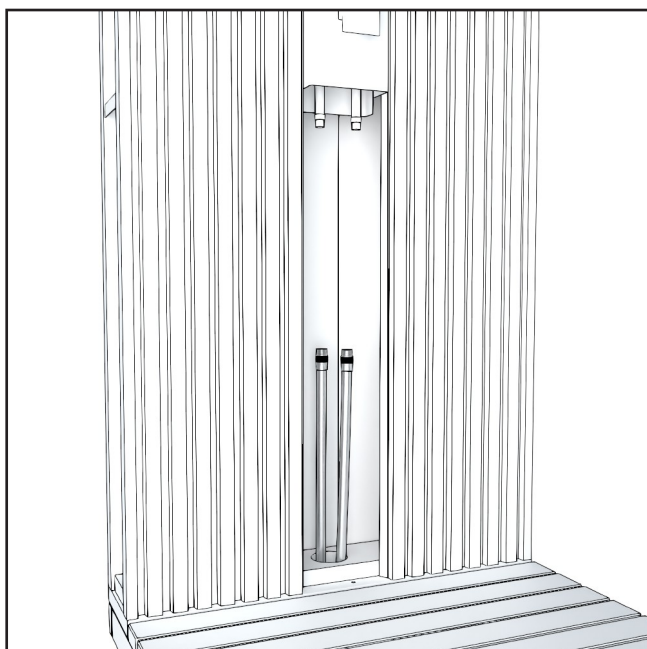

3. Führen Sie den Gartenschlauch/das Rohr in die Wand durch das Loch, das Sie in die Terrasse gebohrt haben, und durch das Loch unter der Außendusche. Schließen Sie Warmwasser auf der linken Seite und Kaltwasser auf der rechten Seite an.

Wenn die Schläuche/Rohre angeschlossen sind, schrauben Sie die beiden Paneele wieder an.

ANSCHLUSS DES WASSERABFLUSSES

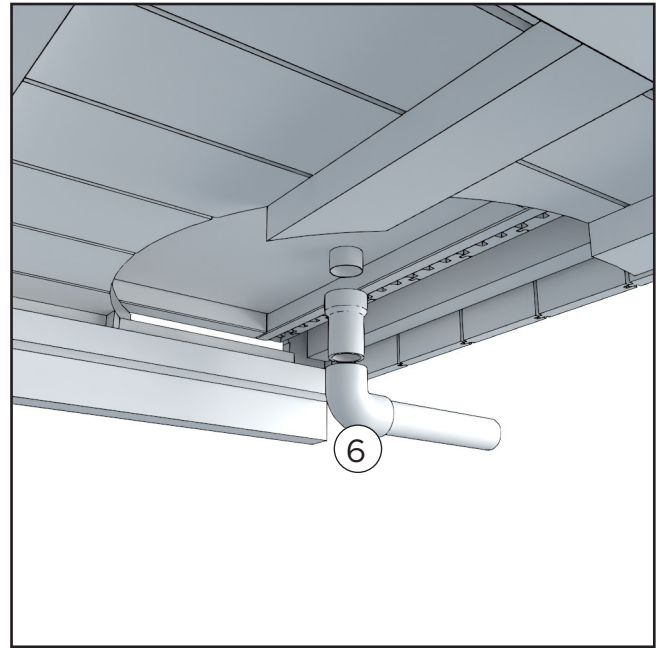
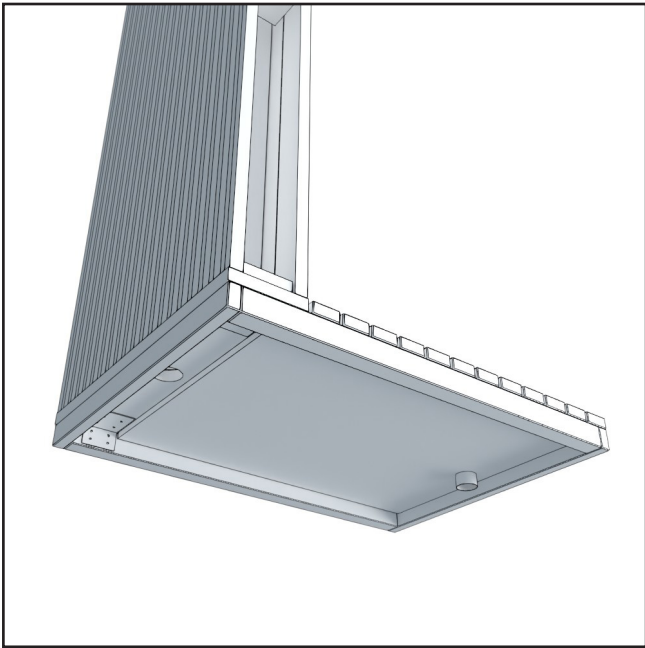

Der Sockel verfügt über einen vorgefertigten 50-mm-Abfluss für Abwasser. Bei der Montage der Kirami FinVision® Terrasse verbinden Sie die Rohrteile in der im Bild gezeigten Reihenfolge, um den Abfluss der Außendusche zur Rückseite des Moduls zu führen.

MONTAGE DER ABLAGEN

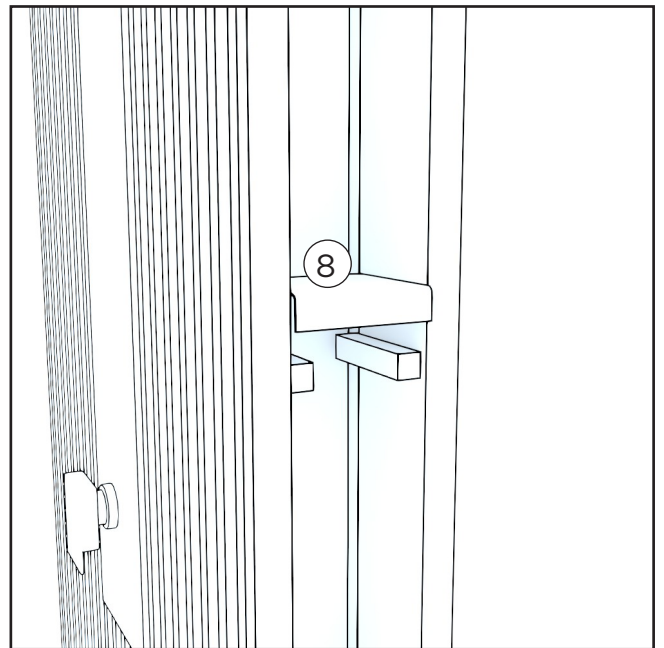
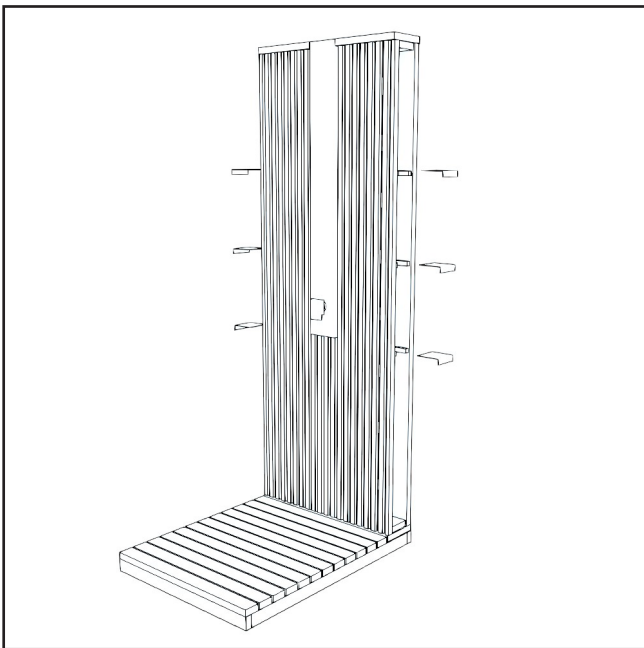

Bei Außenduschen mit einer Duschwand befinden sich an den Seiten Halterungen für Ablagen. Setzen Sie die Ablagen auf die Halterungen.

GARANTIE

Wir gewähren auf unsere Sauna eine Garantie von 24 Monaten auf Material- und Herstellungsfehler. Die Garantie ist gültig, wenn sich der Benutzer mit der Bedienungsanleitung vertraut gemacht hat und diese beachtet.

ACHTUNG! Wenn das Produkt gewerblich genutzt wird, beläuft sich die Garantiezeit auf 6 Monate.

- Die Garantie greift nicht für eventuell auftretende Fehler, die für Holzmaterialien typisch sind, wie z. B. Farbveränderungen, Feuchtigkeitsschwankungen, Rissbildung und ähnliches.
- Die Garantie greift nicht für den Verschleiß bei normaler Nutzung.
- Die Garantie greift auch nicht bei Schäden, die durch Bedienfehler verursacht worden sind.
- Die Garantie gilt nicht für Frostschäden, da diese durch korrekte Nutzung vermieden werden können.
- Die Garantie gilt nicht für mögliche Verätzungen, die durch den falschen Einsatz von Waschmitteln verursacht wurden.
- Die Garantie deckt keine indirekten Kosten, wie z.B. das Anlegen oder Abreißen einer Terrasse.
- Kontaktieren Sie bei Garantieangelegenheiten den Verkäufer des Produkts. Wenn Sie versuchen, das Produkt eigenständig zu reparieren, führt dies zum Verfall der Garantie.

ENTSORGUNG DES PRODUKTS

Die Metallteile des Produkts müssen zum Metallrecycling gebracht werden, die Holzteile können verbrannt werden und das Glas ist dem Glasrecycling zuzuführen. Die übrigen Teile sind als Restmüll zu entsorgen. Gebrauchte LED-Leuchten können in Finnland kostenlos und ohne Neuprodukt-Kaufverpflichtung in Geschäften abgegeben werden, die diese Lampen führen. Alternativ können sie zu einer Recyclingstelle gebracht werden.

Kirami FinVision® -outdoor shower XL Misty



Notice d'emploi

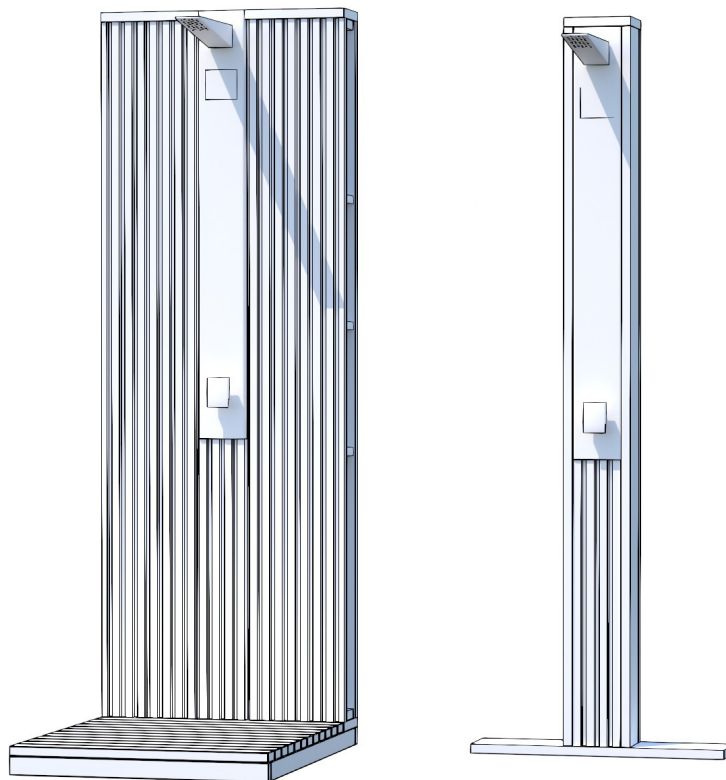

Vérifiez sans tarder le contenu de la livraison !
Veuillez soigneusement prendre connaissance des
consignes d'emploi et les conserver pour une utilisation ul-
térieure.

GÉNÉRALITÉS

Si vous commandez la douche de jardin avec la terrasse, le module de douche est monté en usine sur la terrasse. La paroi de douche peut également être installée ultérieurement, auquel cas elle sera livrée en pièces détachées.

Le module est équipé de raccords préalablement assemblés qui peuvent être raccordés à l'eau chaude et froide ou à un tuyau d'arrosage.

Le caillebotis de la douche équipée d'une plateforme est amovible. Une gouttière en tôle galvanisée située sous le caillebotis dirige les eaux usées vers le tuyau d'évacuation.

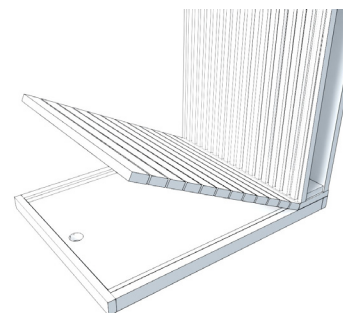

VÉRIFICATION DE LA LIVRAISON

Nous recommandons de vérifier que vous avez reçu une palette en bon état avant de signer le bon de livraison. Si vous constatez ensuite qu'il manque des pièces dans le colis, veuillez contacter le vendeur.











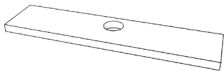

Si vous avez commandé la douche de jardin en même temps que d'autres modules, nous vous invitons à consulter les sections « RACCORDEMENT A L'ARRIVEE D'EAU » et « RACCORDEMENT DE L'ÉVACUATION DES EAUX USÉES ».

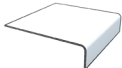
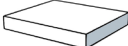

REMARQUE ! En hiver, la douche de jardin doit être vidée de son eau pour éviter les dégâts causés par le gel.

Ouvrez le robinet et soufflez de l'air dans le système.

LISTE DES PIÈCES

Nro	Kuva	Nimi	Pilari (Ilman alustaa)	Pilari (Alustalla)	Suihkuseinä (Terassimalli)	Suihkuseinä (Ulkomalli)
1.		Plancher			1	1
2.		Planche inférieure pour pilier	1	1		
3.		Paroi			1	1
4.		Pilier	1	1		
5.		Pommeau de douche (avec rondelle et écrou)	1	1	1	1
6.		Tuyau d'évacuation		1	1	1
7.		Plaque de raccordement au plafond			1	
8.		Étagère			6	6
9.		Protection - Pilier	1	1		
10.		Plaque de protection				1
11.		Vis 5x35 mm			8	
12.		Vis 4,2 x 19 mm		10	10	10
13.		Vis 4,8x25				4
14.		Vis 4,8 x 75 mm	12	12	4	6

MISE EN PLACE

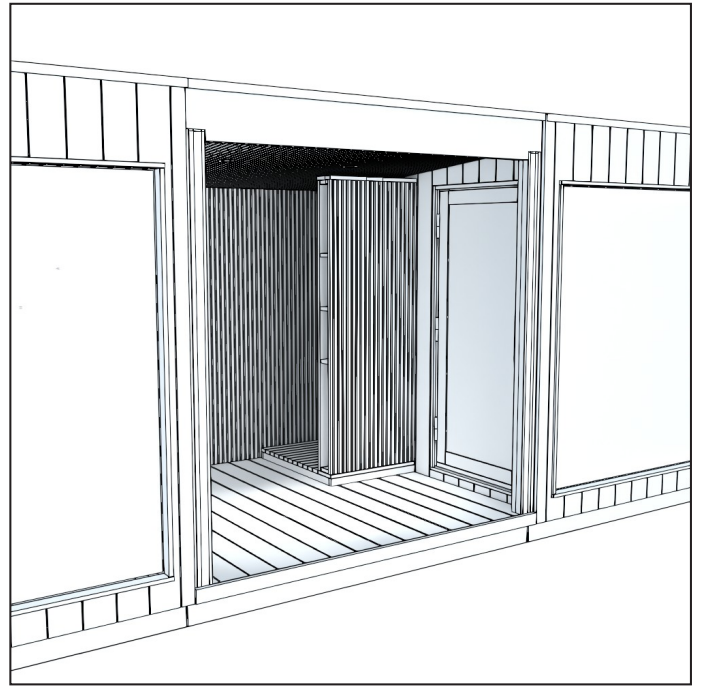
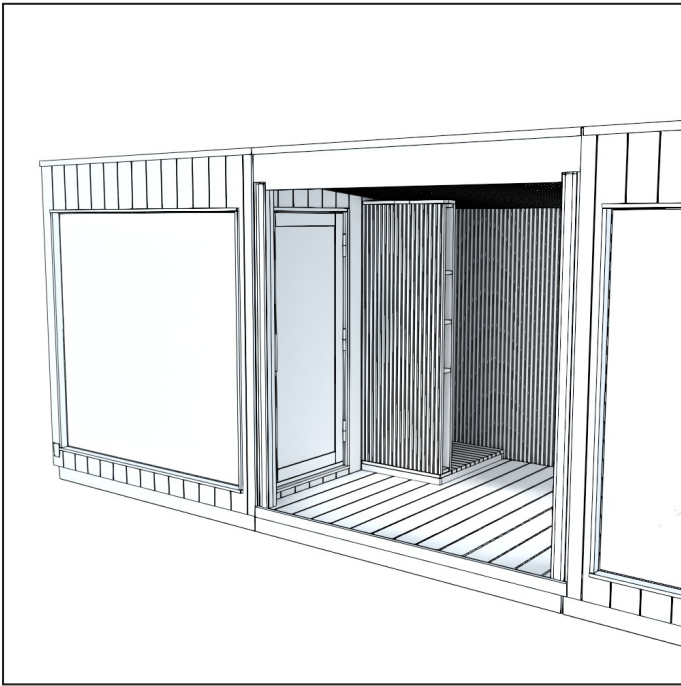

La douche de jardin Misty de Kirami FinVision® (modèle avec terrasse) est toujours installée dans le module terrasse, soit contre le côté gauche soit contre le côté droit, de manière à ce qu'un côté de la douche soit contre un autre module.

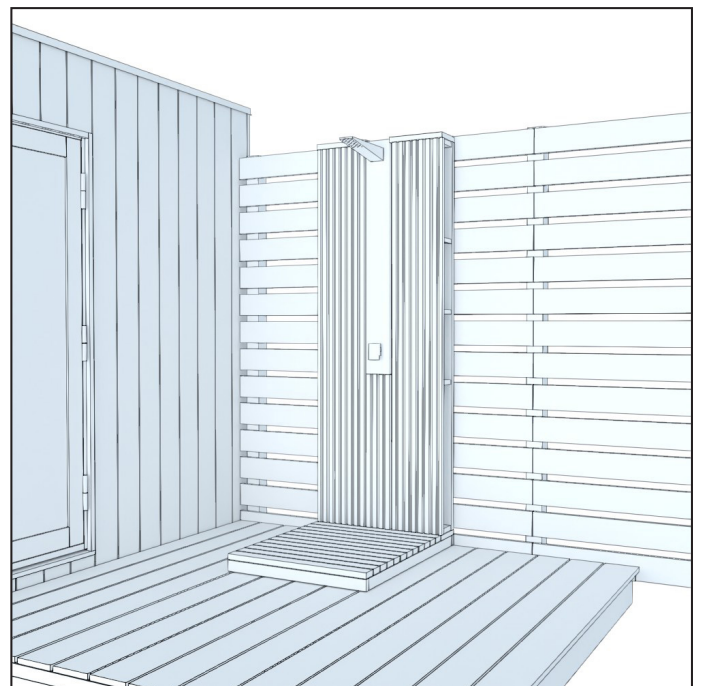
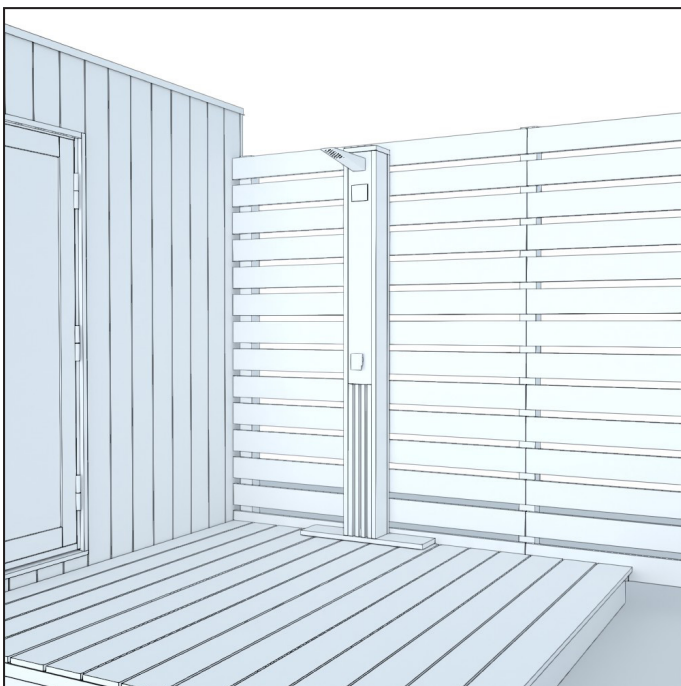

La douche de jardin Kirami FinVision® (modèle hors terrasse) et les modèles Pilier peuvent être installés sur n'importe quelle surface plane, comme une terrasse extérieure ou de toit, près d'un bain nordique, d'une piscine ou d'un sauna.

Il est toujours recommandé d'installer les douches de jardin contre un mur ou toute autre structure stable.

ASSEMBLAGE

Pilier

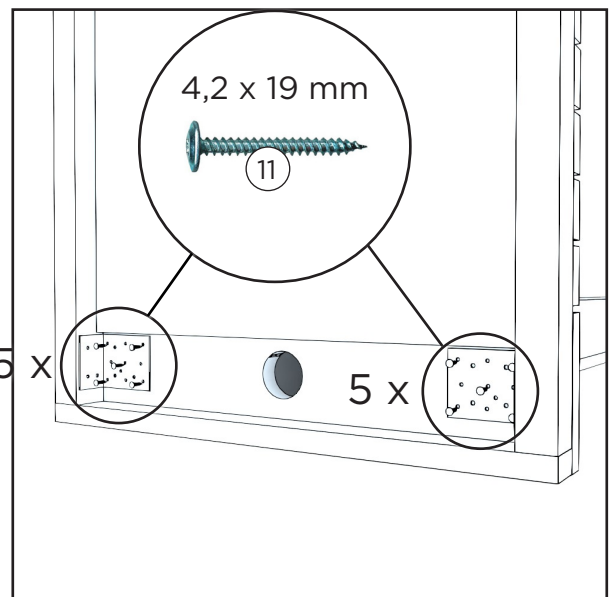
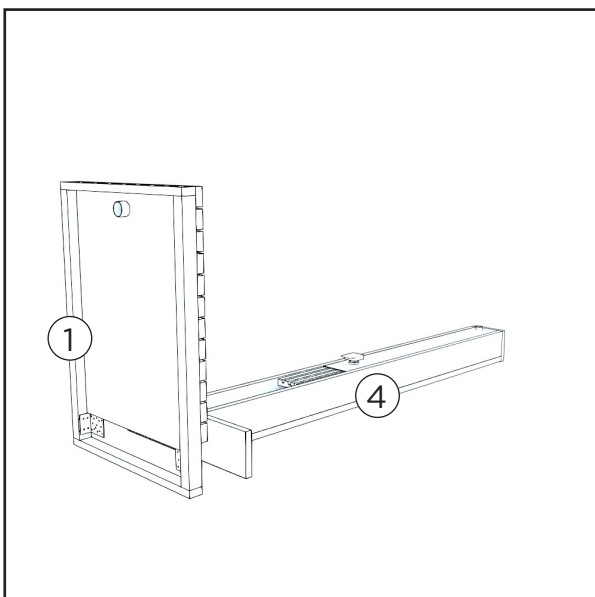
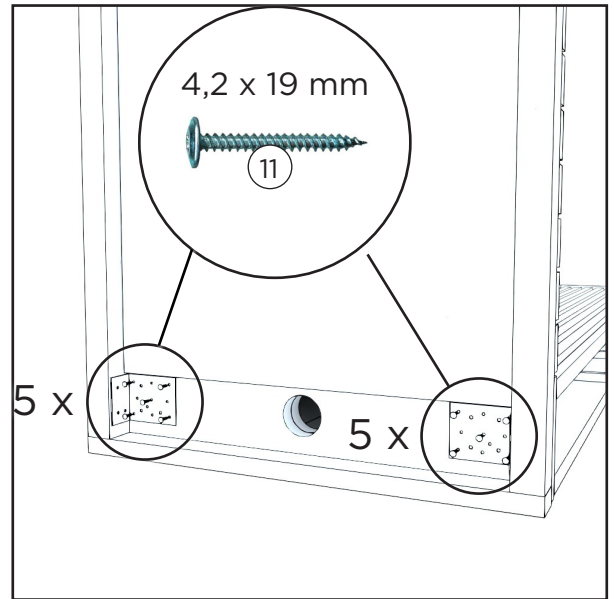
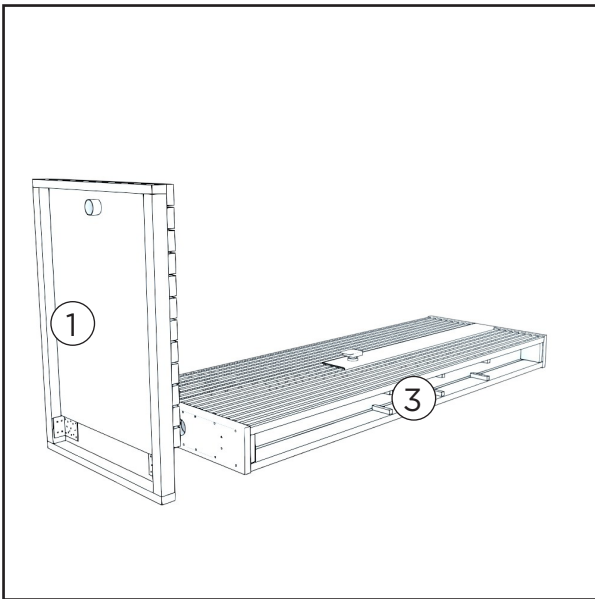
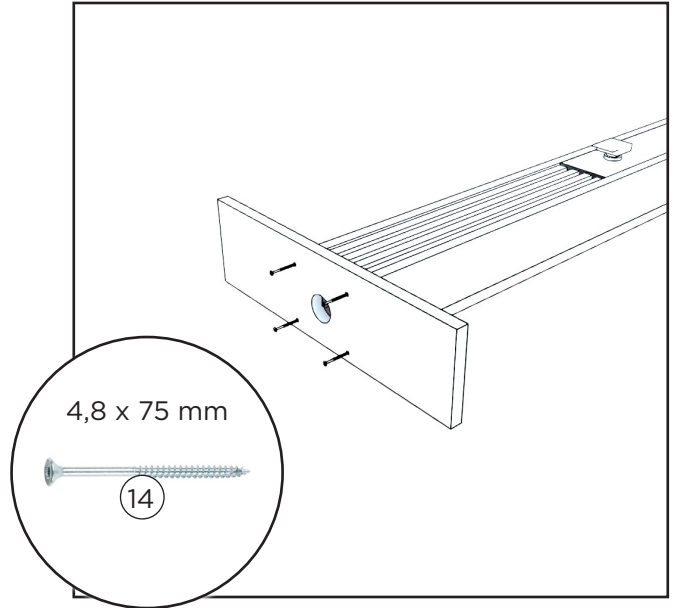
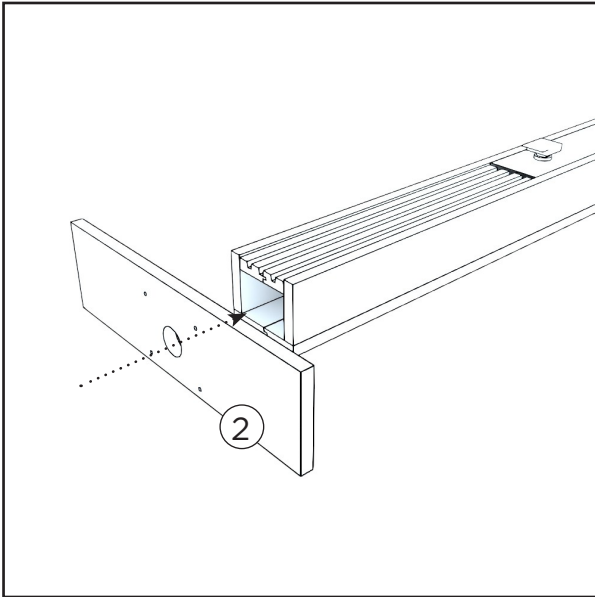

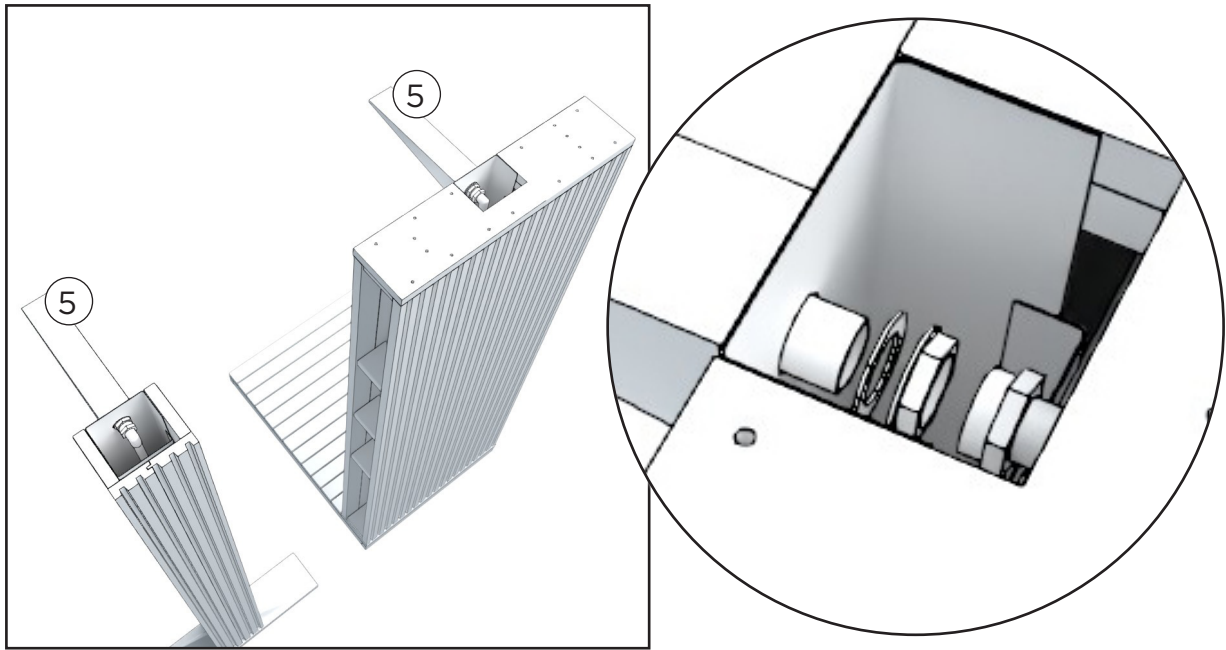

Commencez par fixer le pommeau de douche à la plaque en acier inoxydable à l'aide d'un écrou en laiton ; notez qu'une rondelle doit être placée entre la plaque en acier inoxydable et l'écrou en laiton. Retirez le ruban adhésif du coude à l'intérieur de la douche avant de le raccorder au pommeau de douche.

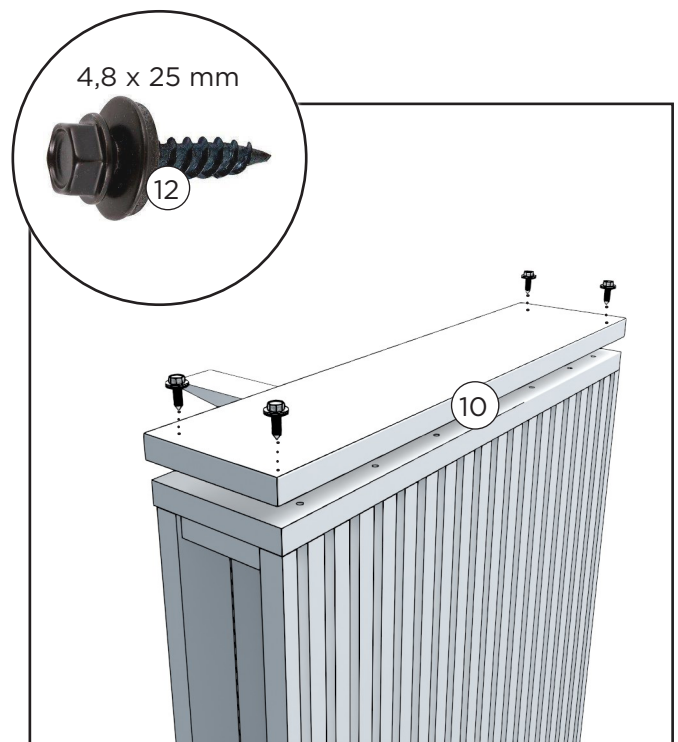
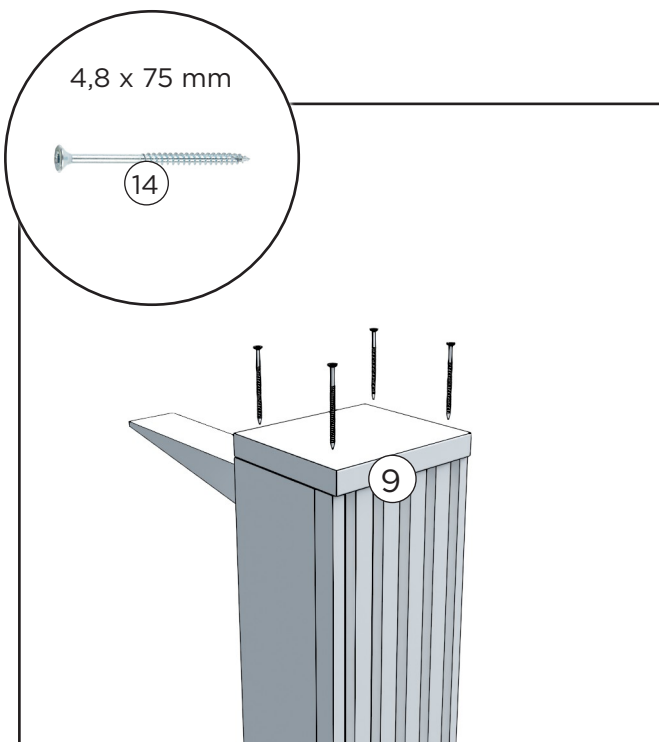

Modèle Pilier : Fixez la protection au sommet de la douche de jardin à l'aide de quatre vis.

Douche de jardin (modèle d'extérieur) : Fixez la plaque de protection au sommet de la douche de jardin à l'aide de quatre vis.

Remarque : Aucune plaque de protection n'est fixée à la douche modèle terrasse.

INSTALLATION D'UNE DOUCHE DE JARDIN SUR LA TERRASSE

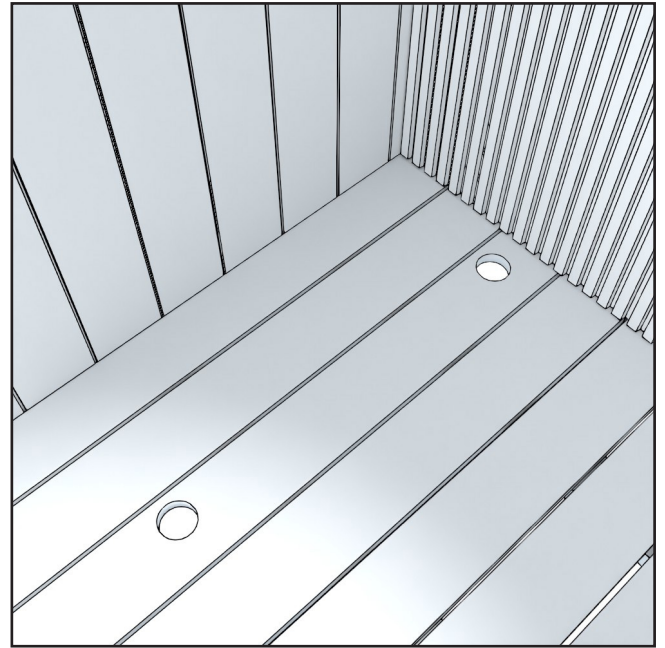
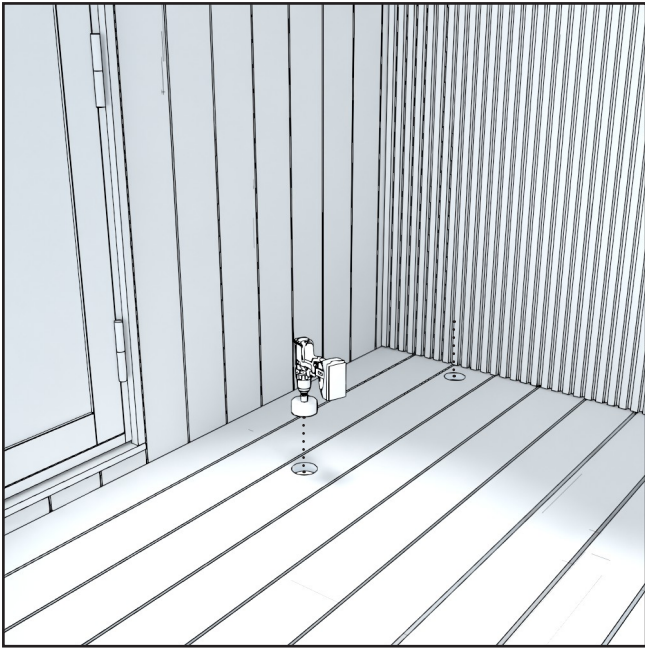

Si la douche de jardin Kirami FinVision® Misty est commandée ultérieurement, des trous doivent être percés dans le module terrasse pour l'arrivée et l'évacuation de l'eau. Le diamètre du trou à percer dans la terrasse doit être d'au moins 73 mm.

Dimensions pour
l'installation du
côté gauche :

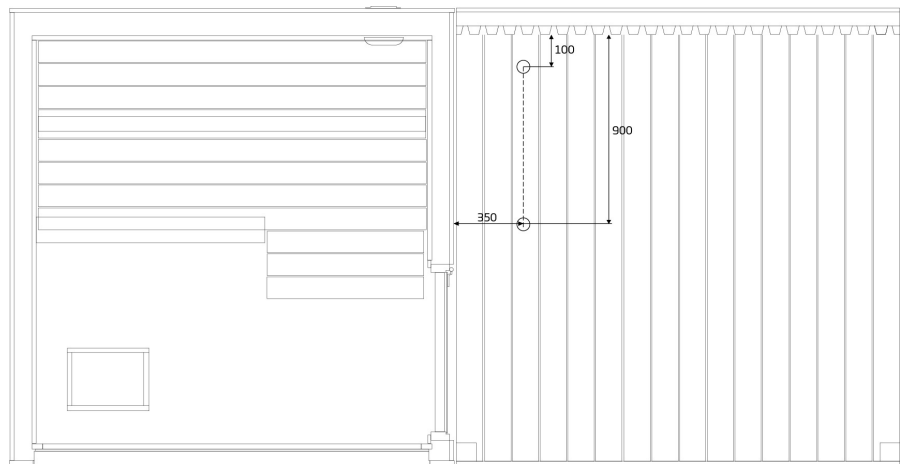

Dimensions pour
l'installation du
côté droit :

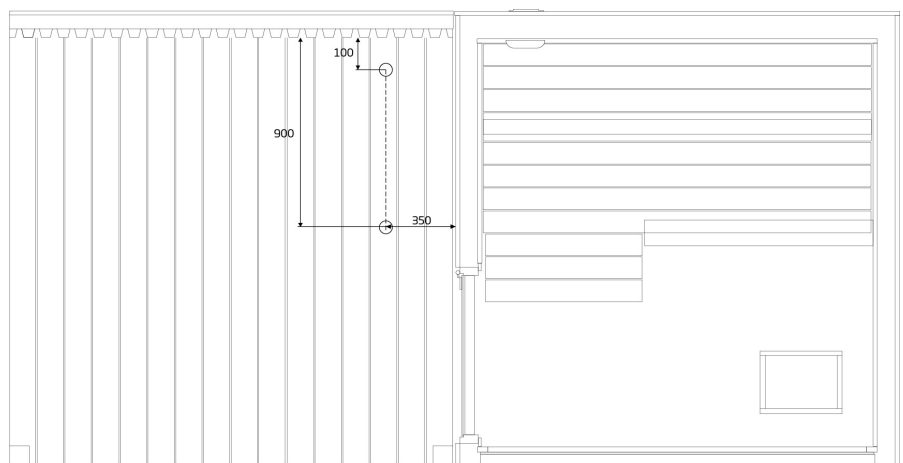

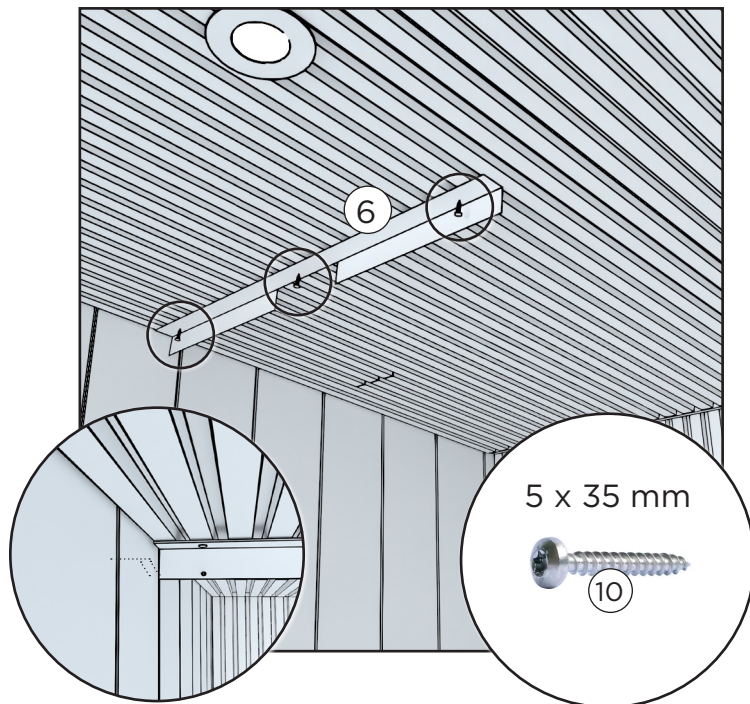
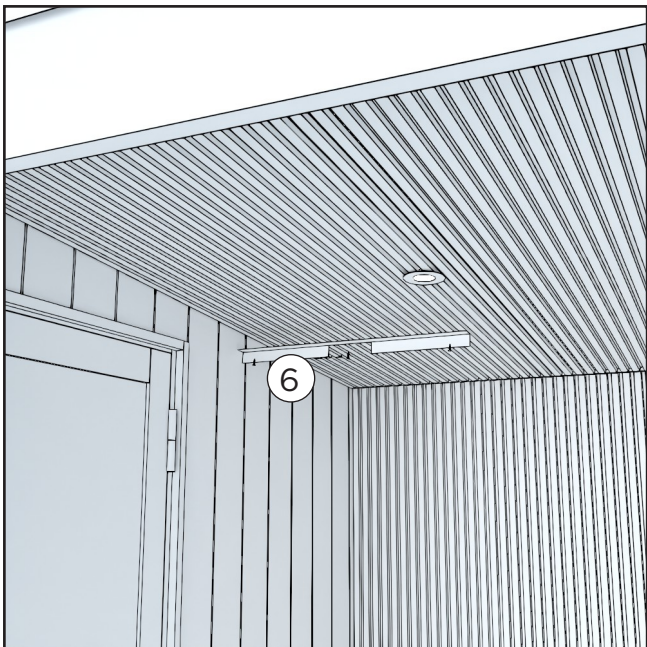

Fixez la plaque de raccordement entre la douche de jardin et le toit au plafond de la terrasse, en la plaçant à 830 mm du mur du fond et à 3-5 mm du mur latéral.

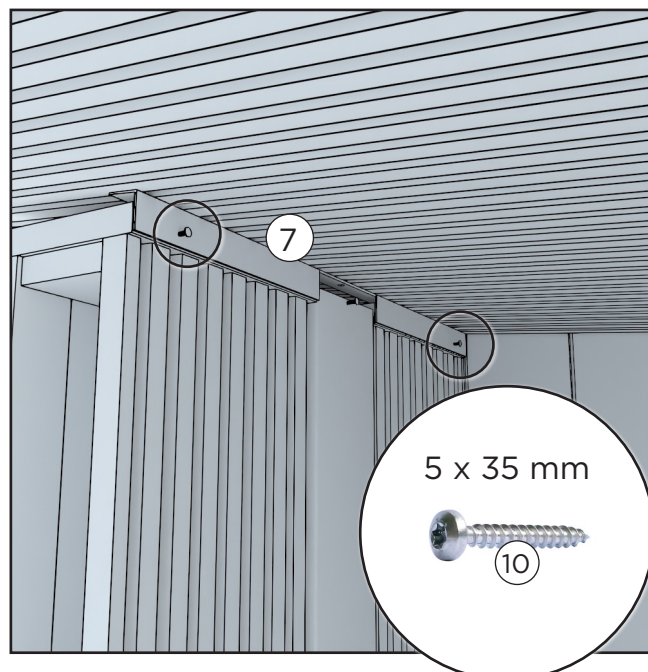
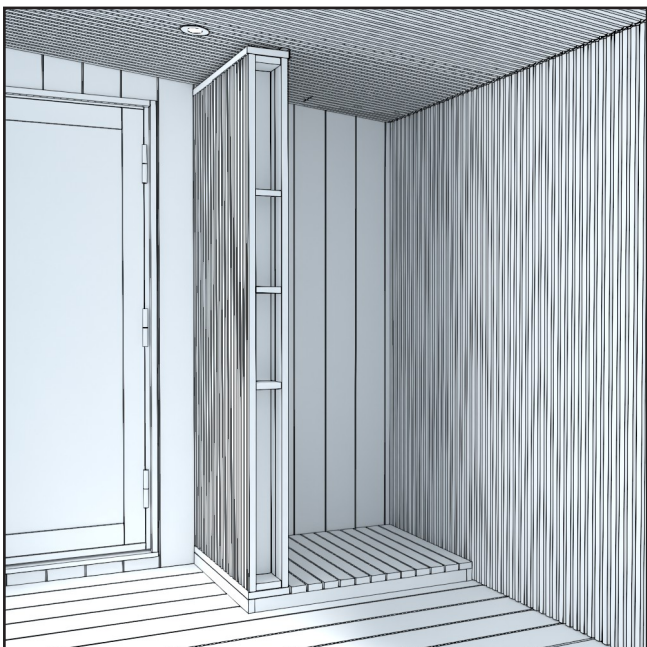

Placez la douche de jardin contre la plaque de raccordement et le mur du fond de la terrasse. Fixez la plaque de raccordement à la douche de jardin à l'aide de vis.

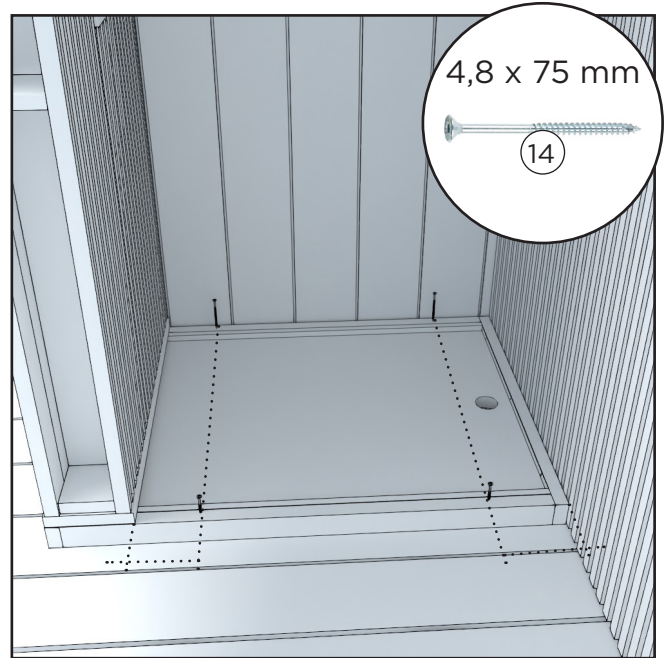
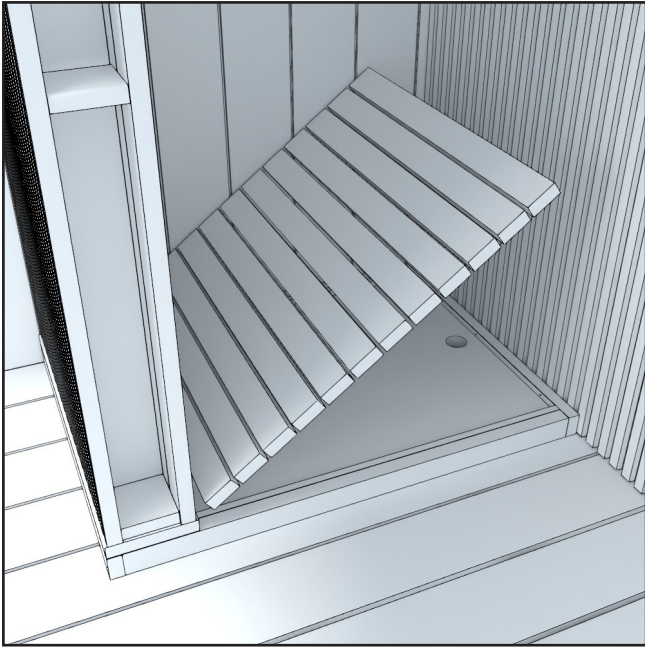

Soulevez le caillebotis et vissez la base sur la terrasse. Remettez le caillebotis de la base en place.

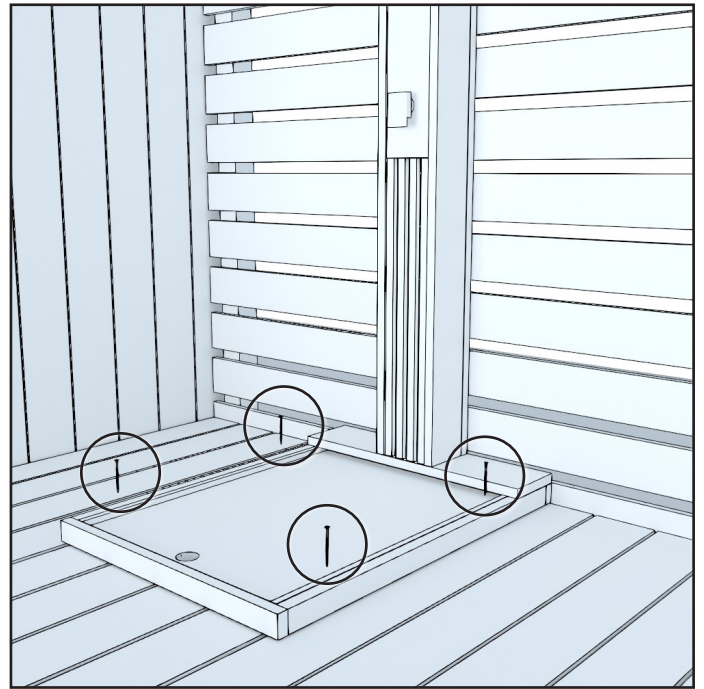
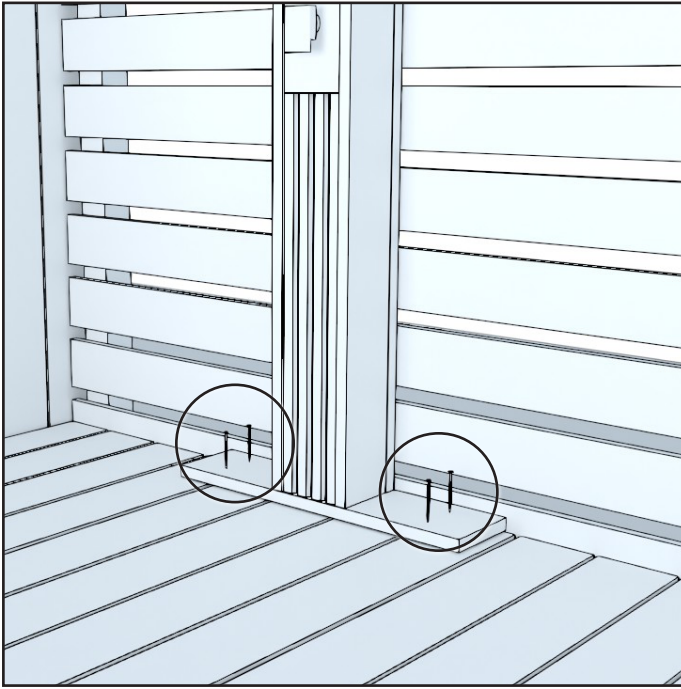
FIXATION D'AUTRES MO-
DÈLES

Pour les douches de jardin sur pilier, fixez la base de la douche de jardin au matériau sur lequel elle repose à l'aide de quatre vis.

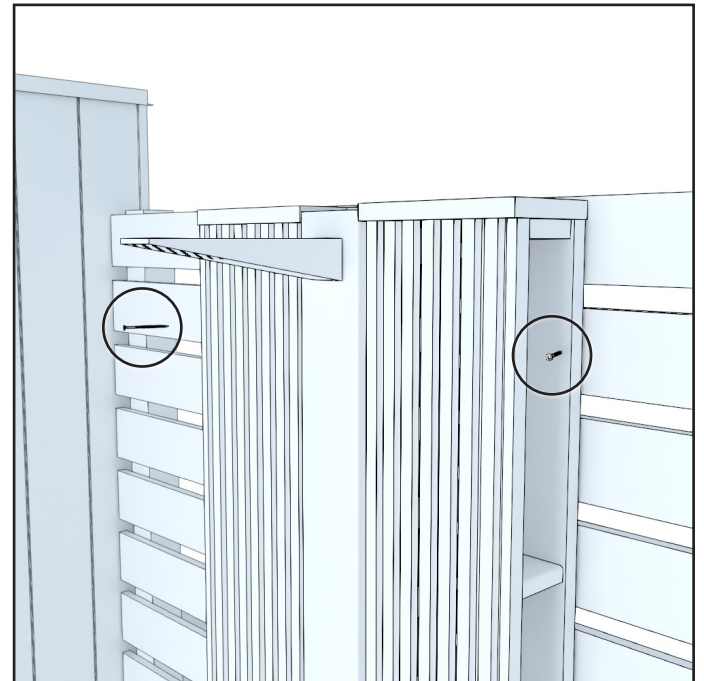
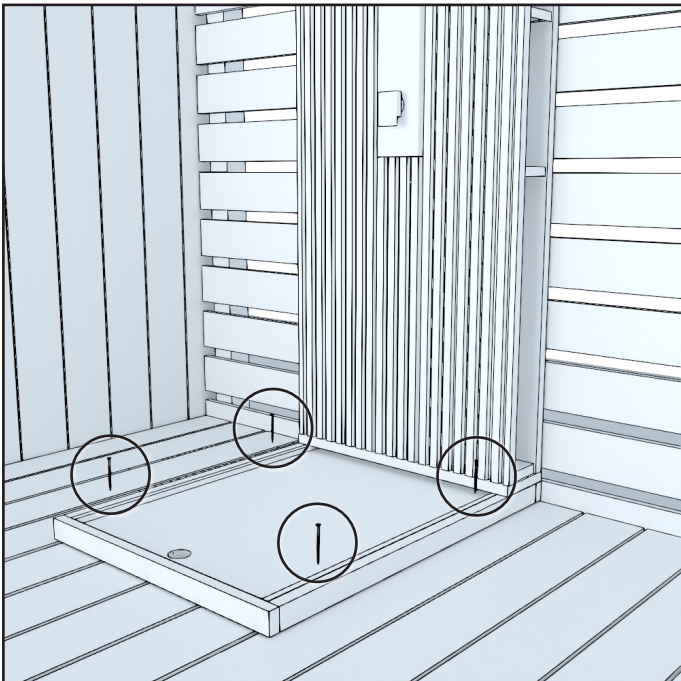

Pour la douche de jardin avec paroi, commencez par fixer la base de la douche de jardin au matériau sur lequel elle repose à l'aide de quatre vis. Fixez ensuite le haut de la paroi de part et d'autre sur le matériau contre lequel est appuyée la douche à l'aide de vis.

RACCORDEMENT A L'ARRIVEE D'EAU

Le module est équipé de raccords préalablement assemblés qui peuvent être raccordés à l'eau chaude et froide ou à un tuyau d'arrosage.

RACCORDEMENT AU TUYAU D'ARROSAGE

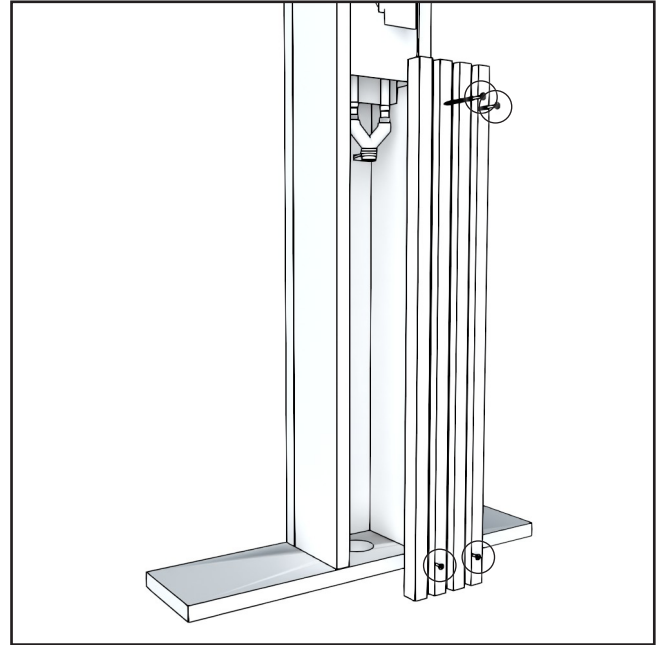
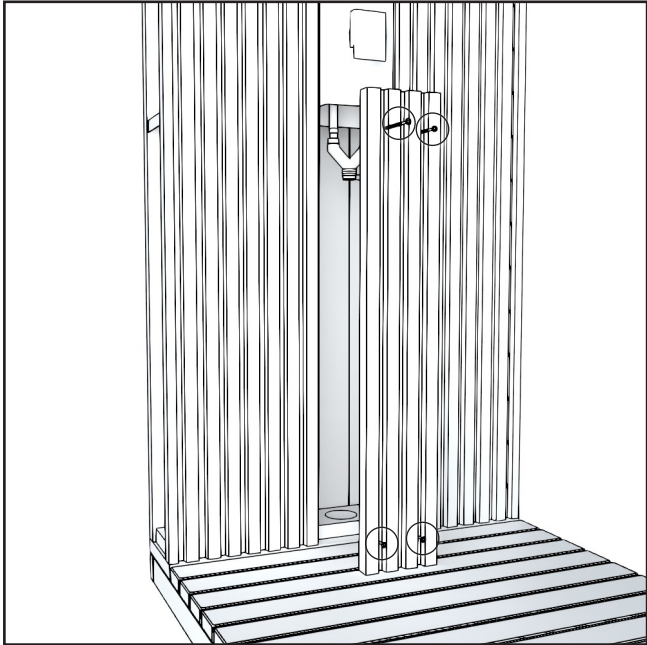

1. Les connecteurs d'entrée d'eau sont dissimulés derrière les panneaux avant. Retirez les panneaux.

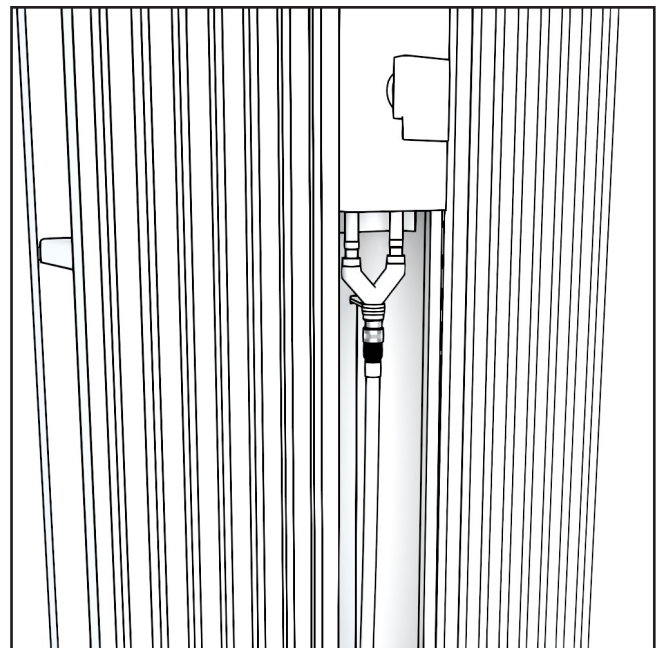

2. Faites passer le tuyau d'arrosage par le trou situé au bas de la douche de jardin et dans la paroi, puis raccordez-le à la douche.

Une fois le tuyau raccordé, remettez les deux panneaux en place.

RACCORDEMENT A L'EAU CHAUDE ET FROIDE

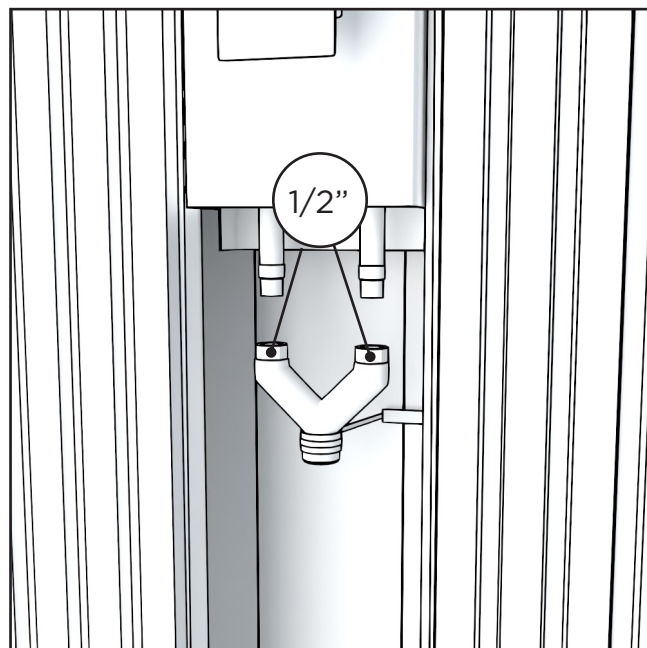
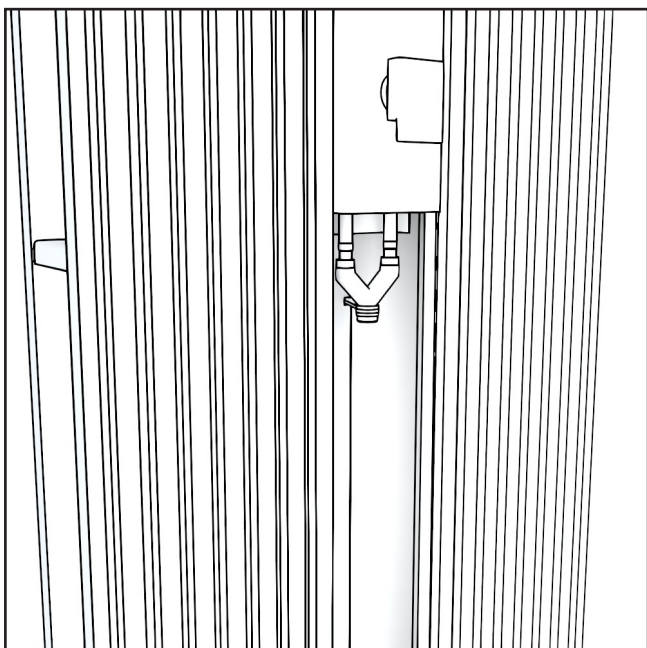

1. Retirez le séparateur de tuyaux en laiton en tournant les écrous dans le sens inverse des aiguilles d'une montre et en détachant le support du mur.

Quick
coupling
nipple
1/2" (15)

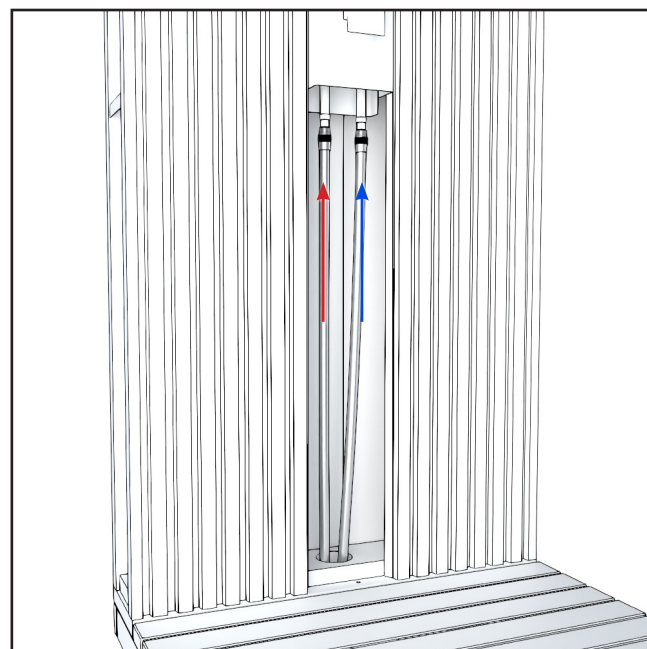
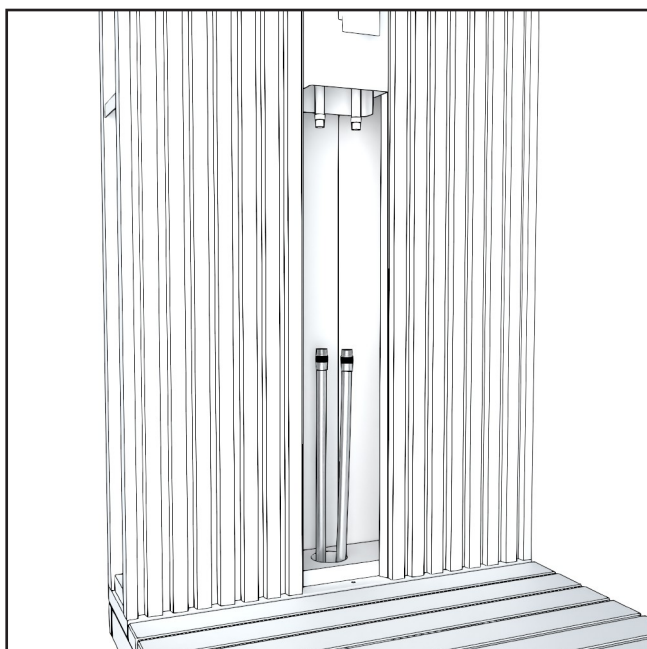

2. Faites passer les tuyaux d'arrosage dans le mur par le trou que vous avez percé dans la terrasse et par le trou situé sous la douche de jardin. Raccordez l'eau chaude au côté gauche et l'eau froide au côté droit.

Lorsque les tuyaux/conduites sont raccordés, revissez les panneaux.

RACCORDEMENT DE LA CONDUITE D'ÉVACUATION DE L'EAU

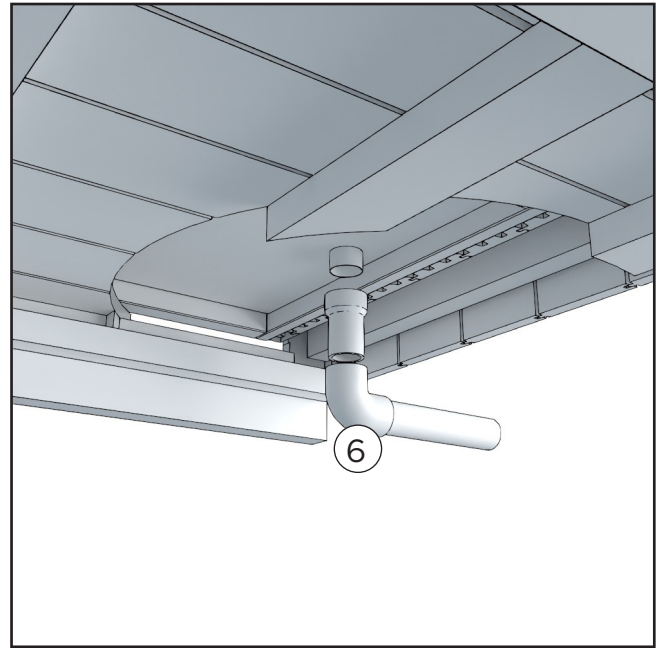
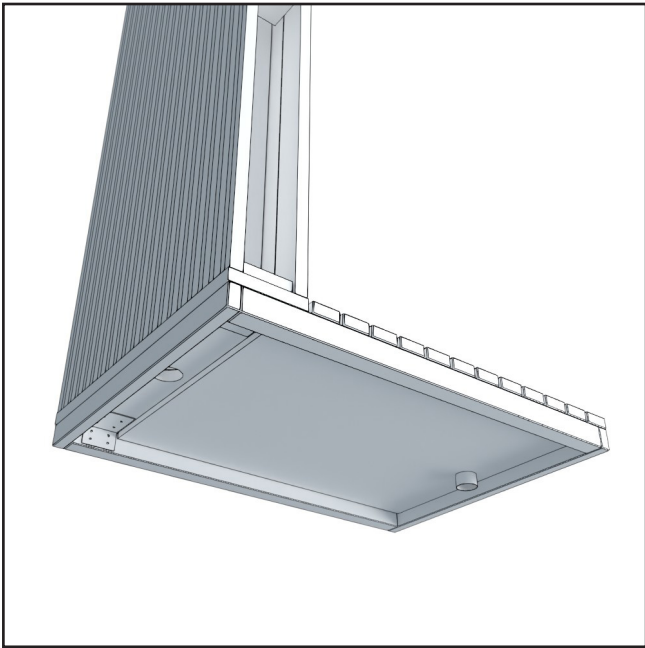

La base présente une sortie de 50 mm prévue pour l'évacuation des eaux usées. Lors de l'installation de la terrasse Kirami FinVision®, raccordez les éléments de tuyauterie dans l'ordre indiqué sur l'image pour diriger l'évacuation de la douche de jardin vers l'arrière du module.

FIXATION DES ÉTAGÈRES

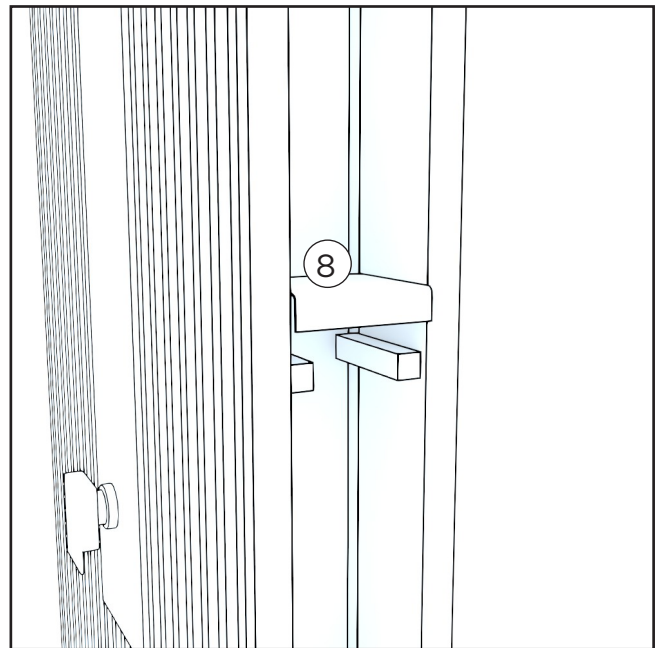
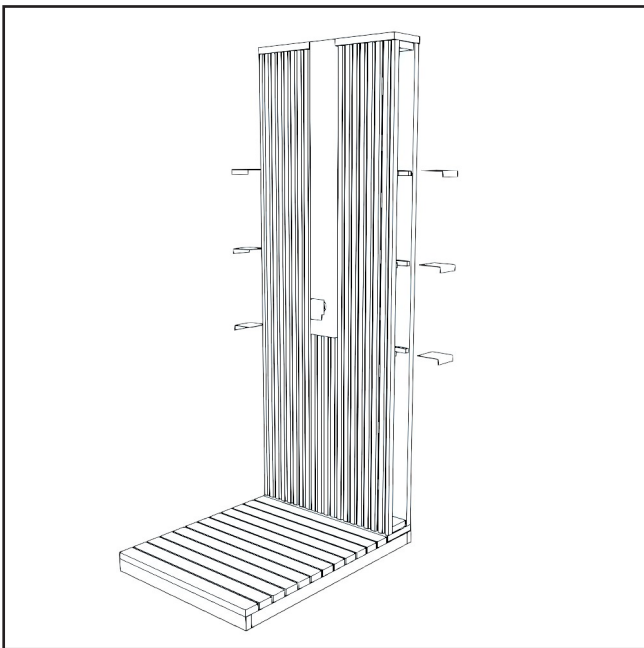

Les douches de jardin avec paroi de douche présentent des supports d'étagères sur les côtés. Placez les étagères sur les supports.

GARANTIE

Nous garantissons nos produits 24 mois contre les défauts de matériel et de fabrication. La garantie est valide si l'utilisateur a pris connaissance des instructions d'utilisation du produit et les observe.

NB ! Par dérogation à la durée de garantie indiquée ci-dessus, les produits utilisés à des fins commerciales sont garantis 6 mois seulement.

- La garantie ne couvre pas l'apparition d'éventuels défauts qui sont typiques aux matériaux en bois. Par exemple, le changement de coloration, les variations d'humidité, la formation de fissures et autres.
- La garantie ne couvre pas l'usure normale due à l'utilisation.
- Elle ne prend non plus en charge les défauts dus à une utilisation erronée.
- La garantie ne couvre aucun dégât causé par le froid, puisque ceux-ci sont évitables avec un usage correct.
- La garantie ne concerne pas les corrosions dues à l'éventuelle utilisation erronée de détergents.
- La garantie ne couvre pas des frais intermédiaires, par ex. la construction ou la démolition de la terrasse.
- Dans les affaires relatives à la garantie, veuillez contacter le vendeur. Si vous tentez de réparer vous-même le produit, la garantie sera annulée.

MISE AU REBUT DU PRODUIT

Les composants métalliques du produit doivent être ramenés au point de recyclage, et les éléments en bois peuvent être brûlés, le verre doit être emmené au point de recyclage du verre. Les autres composants font partie de la mise au rebut d'ordures mixtes. En Finlande, les lampes LED peuvent être retournées gratuitement et sans obligation d'achat dans les magasins proposant ce genre de lampes ou bien elles peuvent être emmenées au point de recyclage.

Kirami FinVision® -outdoor shower XL Misty



Gebruikershandleiding

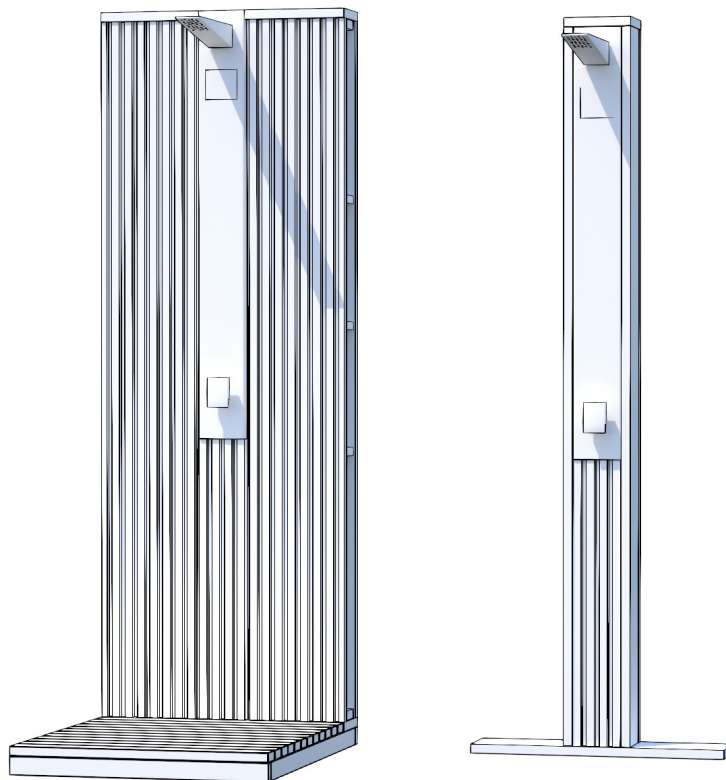

Controleer eerst en vooral de inhoud van de levering!
Lees zorgvuldig de instructies en hou deze goed bij.

ALGEMEEN

Als u de douche mét terras bestelt, is de douchemodule voorgemonteerd op het terras. De douchewand kan ook achteraf geïnstalleerd worden, waarbij deze in afzonderlijke delen wordt geleverd.

De douche is uitgerust met voorgemonteerde aansluitingen, die zowel op koud- als warmwaterleidingen kunnen worden aangesloten, of op een tuinslang. Het vloerrooster van de douche kan verwijderd worden.

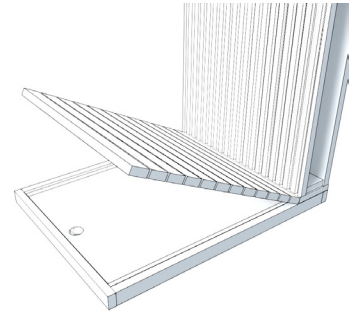

Het vloerrooster van de douche kan verwijderd worden. Onder het rooster zit een bak van gegalvaniseerd plaatstaal dat het waswater naar de afvoerleiding brengt.

CONTROLE LEVERING

We raden aan om steeds te controleren dat u pallet in goede staat hebt ontvangen vooraleer de leveringsbon te ondertekenen. Als u nadien merkt dat er iets ontbreekt in de buitendouche, neemt u contact op met de firma die de sauna leverde.



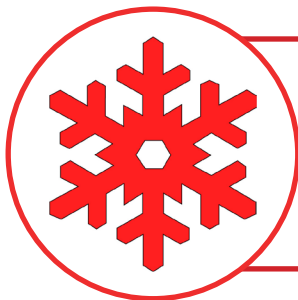







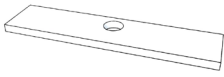

Als u de buitendouche tegelijk met de andere modules hebt besteld, kunt u naar de hoofdstukken "AANSLUITING WATER" en "AANSLUITING WATERAFVOER" gaan.

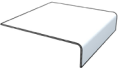
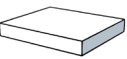

OPMERKING! In de winter moet de buitendouche worden geleegd om vorstschade te voorkomen.

Open de kraan en blaas lucht door het systeem.

ONDERDELENLIJST

Nro	Kuva	Nimi	Pilari (Ilman alustaa)	Pilari (Alustalla)	Suihkuseinä (Terassimalli)	Suihkuseinä (Ulkomalli)
1.		Douchevloer			1	1
2.		Bodemplank voor een pilaar	1	1		
3.		Wand			1	1
4.		Pilaar	1	1		
5.		Douchekop (met ring en moer)	1	1	1	1
6.		Afvoerpijp		1	1	1
7.		Verbindingsplaat met het plafond			1	
8.		Plank			6	6
9.		Bescherming - Pilaar	1	1		
10.		Beschermingsplaat				1
11.		Schroef 5x35 mm			8	
12.		Schroef 4,2x19 mm		10	10	10
13.		Schroef 4,8x25				4
14.		Schroef 4,8x75 mm	12	12	4	6

PLAATSING

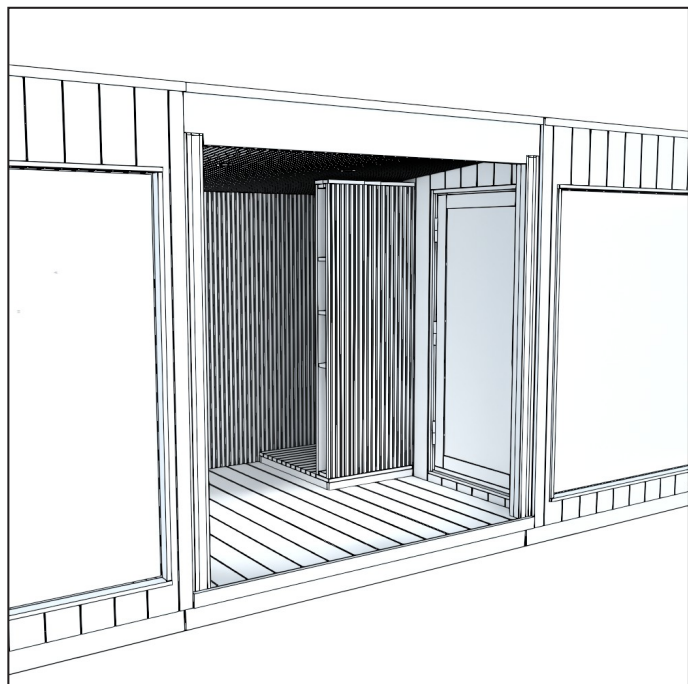
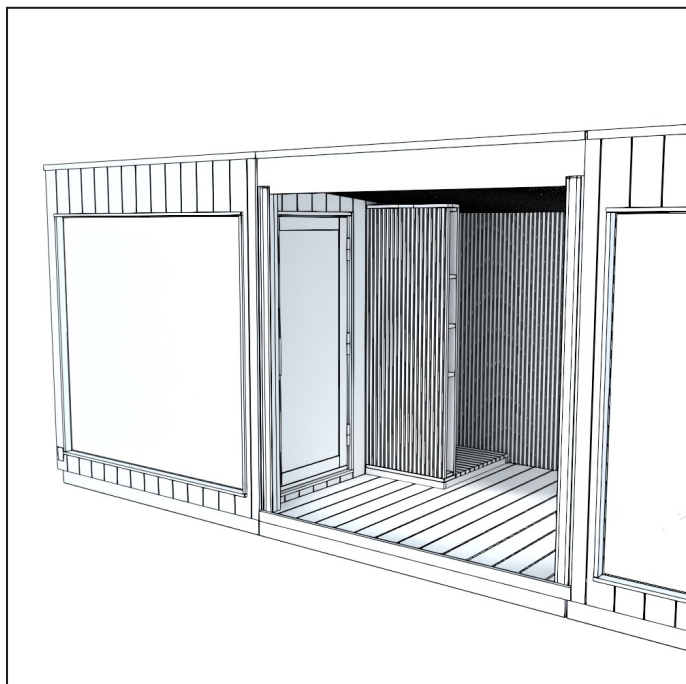

De Kirami FinVision® Misty-buitendouche (terrasmodel) wordt steeds geïnstalleerd in het Kirami FinVision® -terras, aan de linker- of rechterkant. Daardoor staat de buitendouche altijd met één kant tegen een andere module.

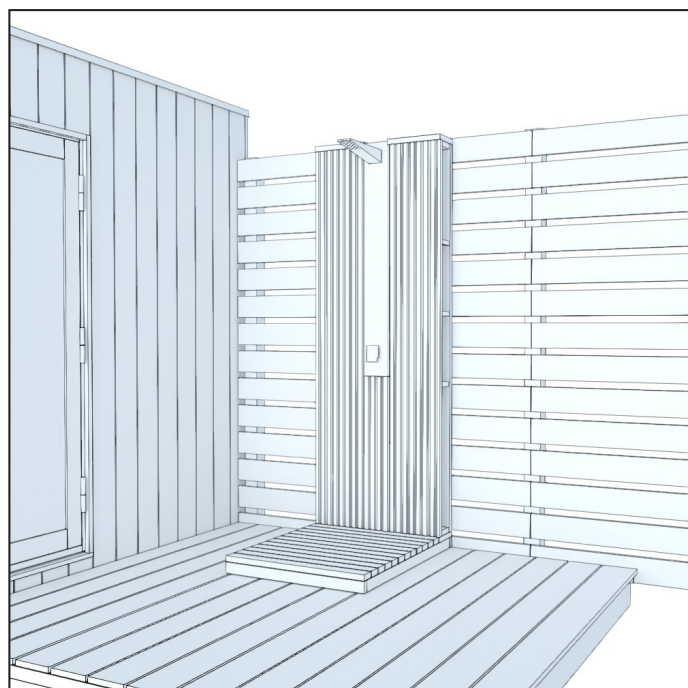
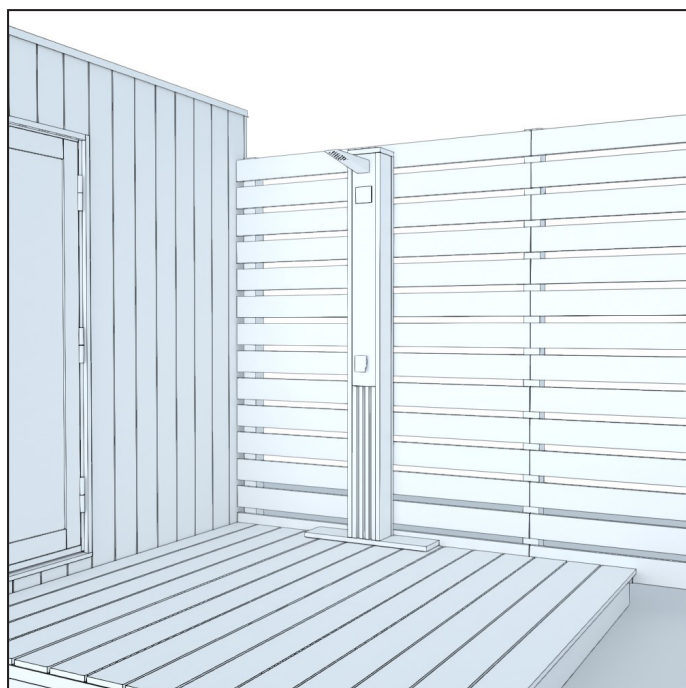

De Kirami FinVision® -buitendouche (niet-terrasmodel) en Pilaar-modellen kunnen op elke vlakke ondergrond geplaatst worden, zoals een buiten- of dakterras, bij een hottub, zwembad of sauna.

Buitendouches moeten altijd tegen een muur of andere stabiele structuur geplaatst worden.

ASSEMBLAGE

Pilaar

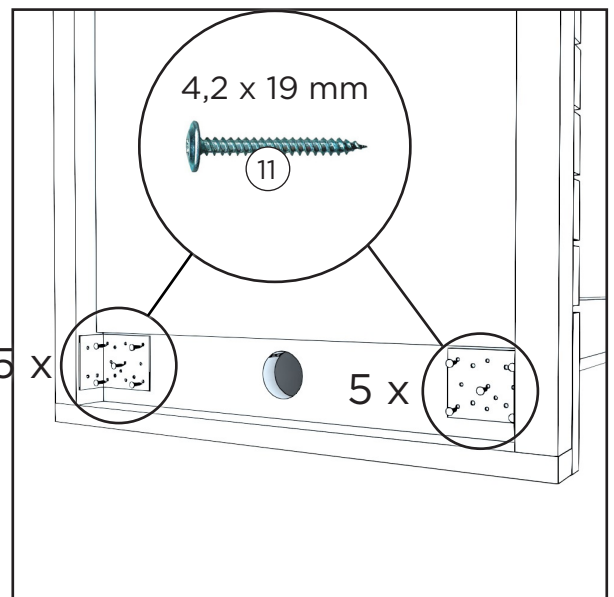
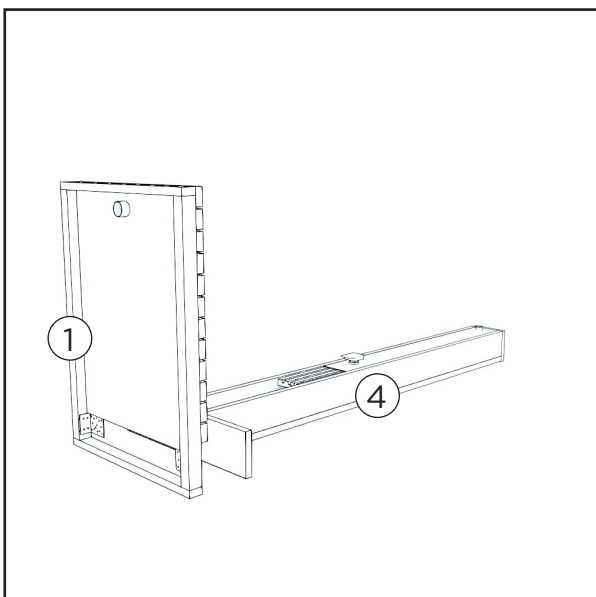
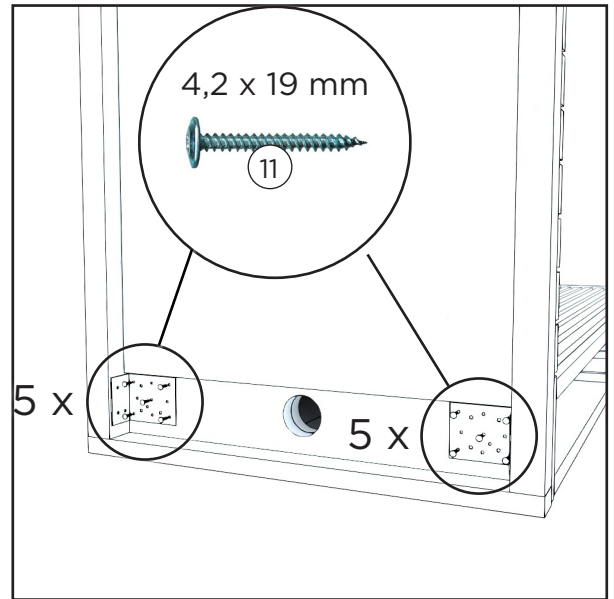
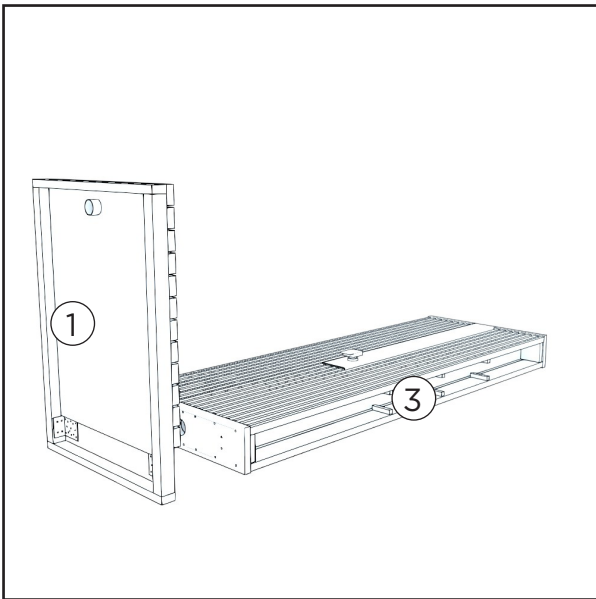
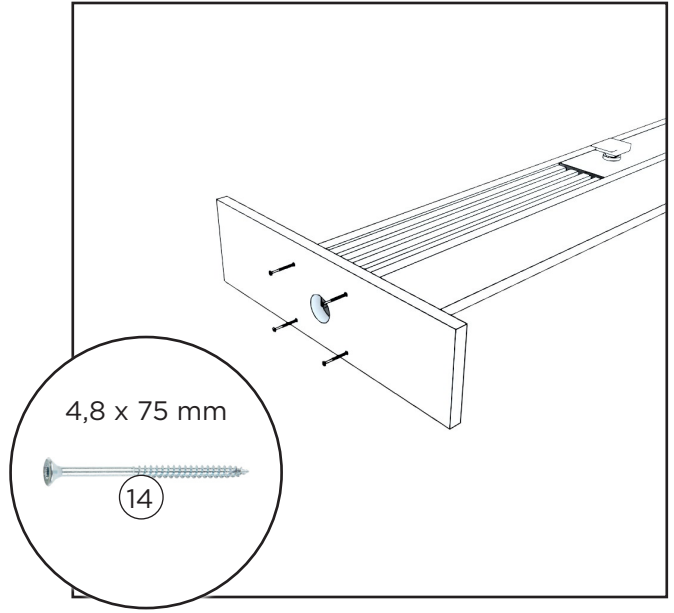
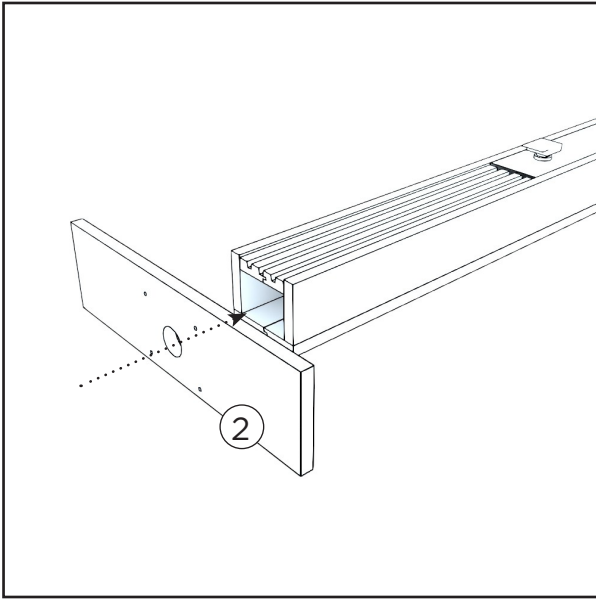

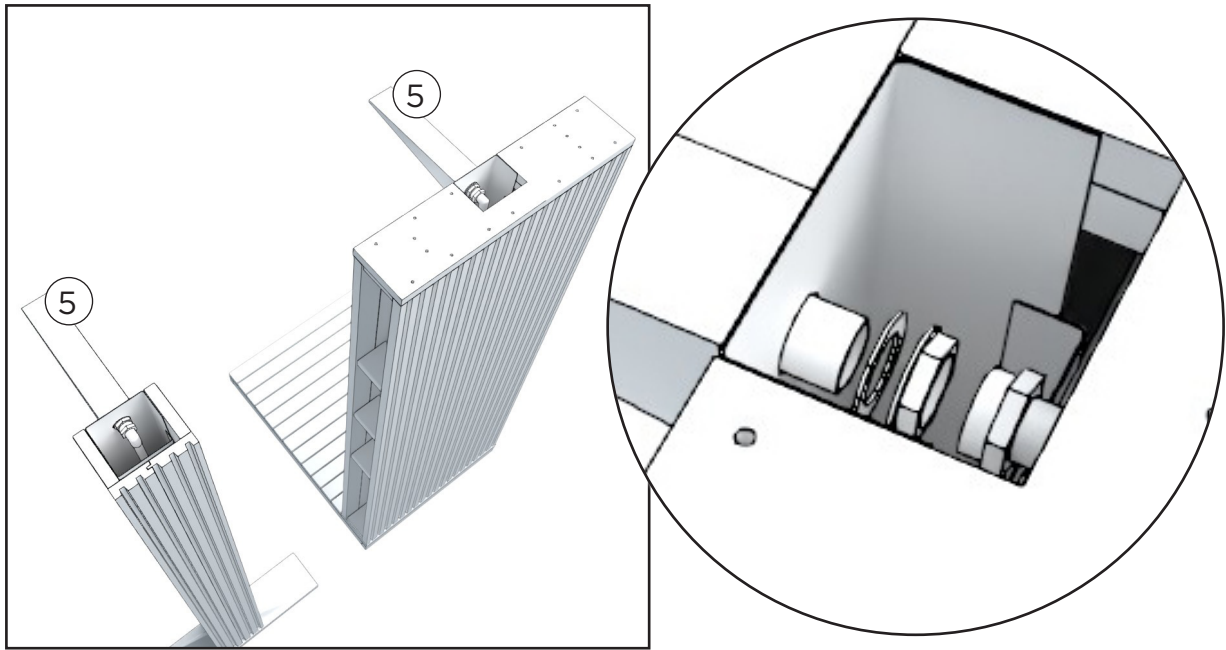

Bevestig de douchekop eerst aan de roestvrijstalen plaat met behulp van een messing moer; weet dat er tussen de roestvrijstalen plaat en de messing moer altijd een ring moet worden geplaatst. Verwijder de tape uit de elleboog in de douche en maak deze vast aan de douchekop.

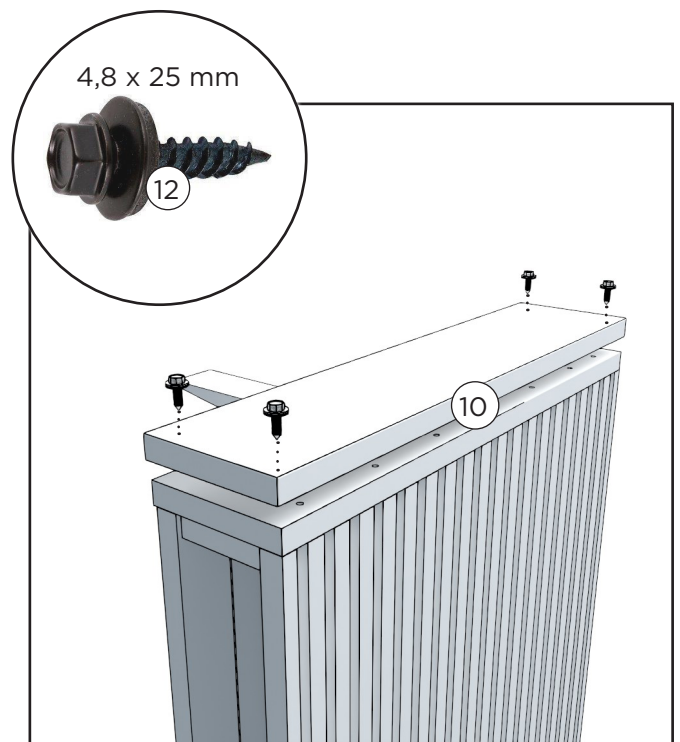
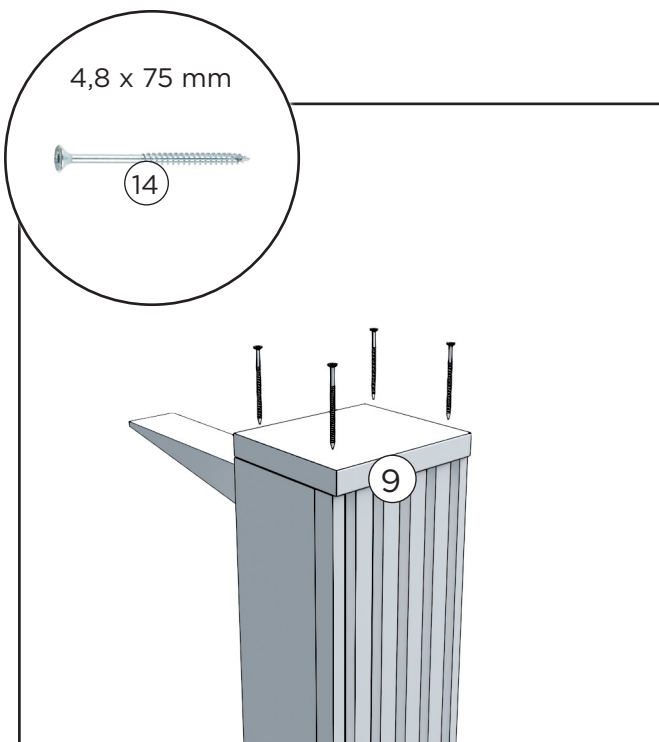

Pilaar-model: Bevestig het uiteinde met vier schroeven aan de buitendouche.

Buitendouche (buitenmodel): Bevestig de beschermplaat met vier schroeven aan het uiteinde van de buitendouche.

Opmerking: Aan de terrasmodel-douche is er geen beschermplaat bevestigd.

INSTALLATIE VAN EEN BUITENDOUCHE OP HET TERRAS

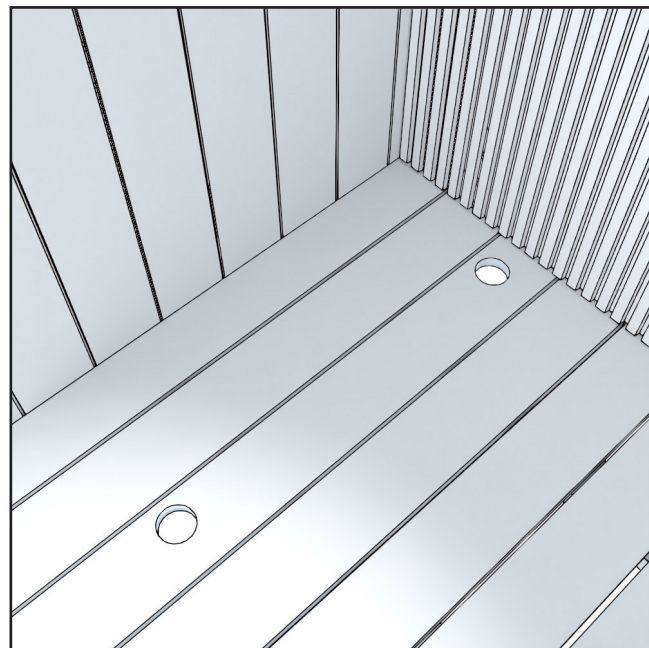
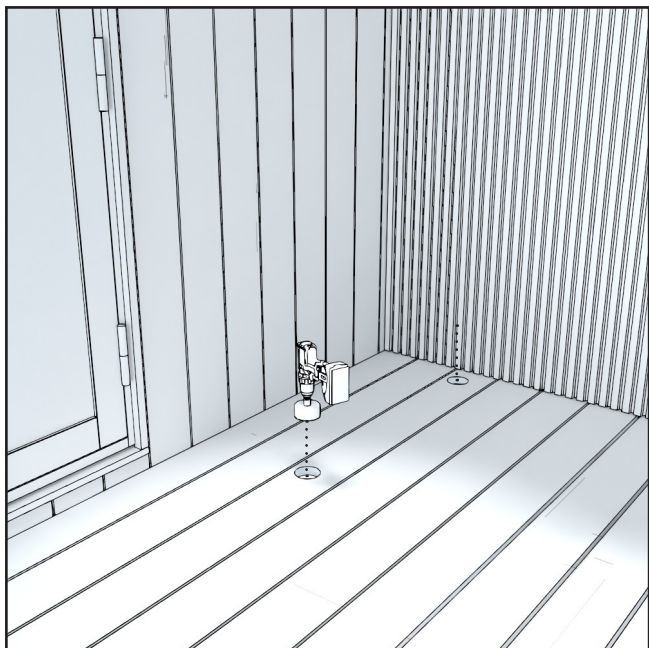

Wanneer de Kirami FinVision® -buitendouche Misty achteraf wordt besteld, moeten in de terrasmodule gaten worden geboord voor de watertoevoer en -afvoer. De diameter van het in het terras te boren gat bedraagt ten minste 73 mm.

Afmetingen voor de installatie aan de linkerkant:

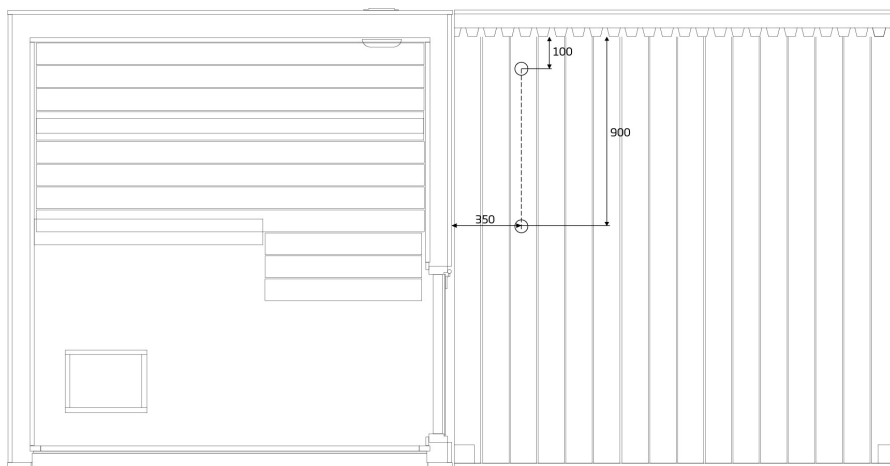

Afmetingen voor de installatie aan de rechterkant:

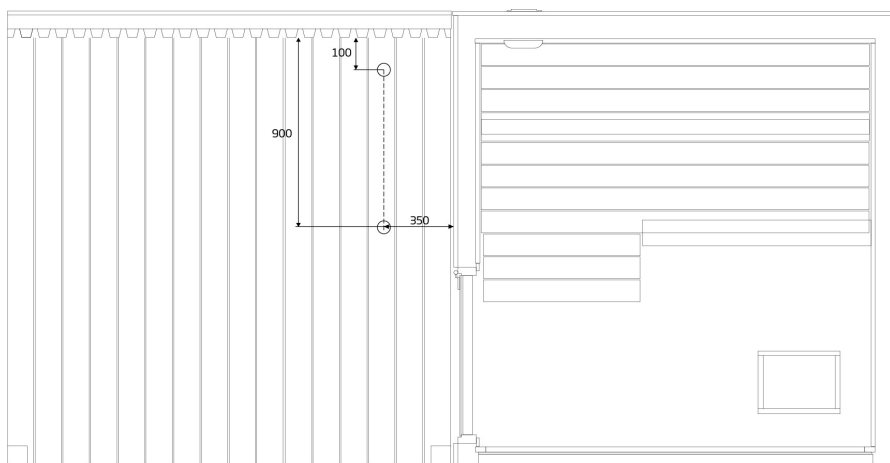

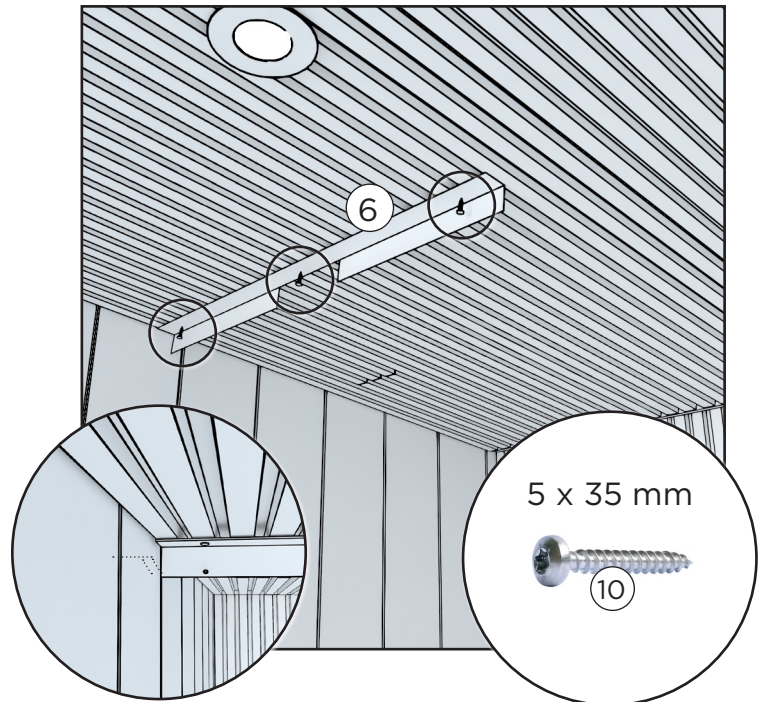
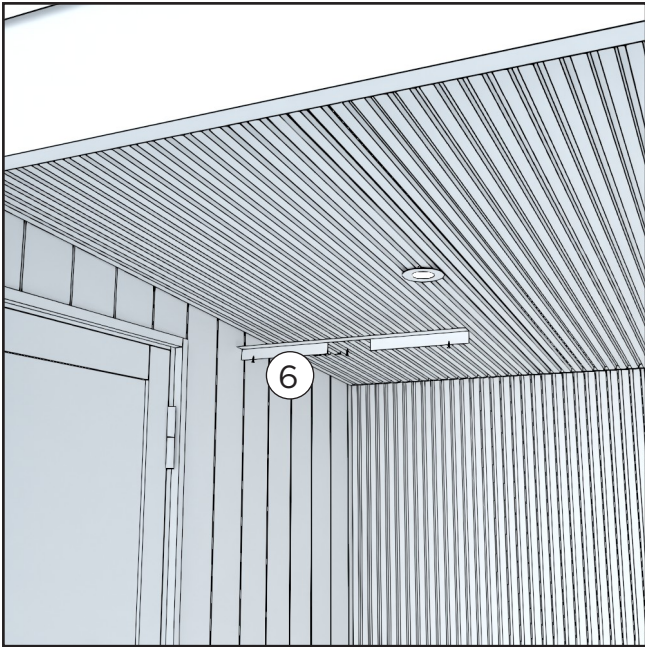

Maak de verbindingsplaat tussen de buitendouche en het dak vast aan het terrasplafond, waarbij ze zich op 830 mm van de achterwand en 3-5 mm van de zijwand bevindt.

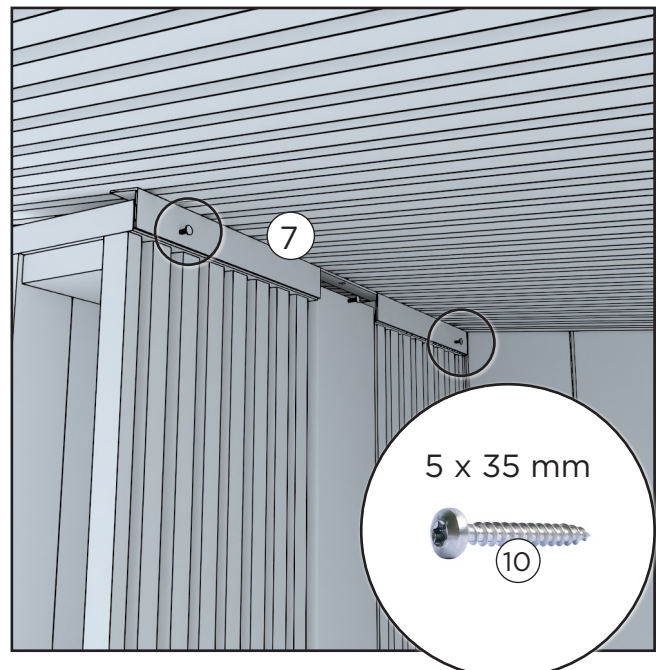
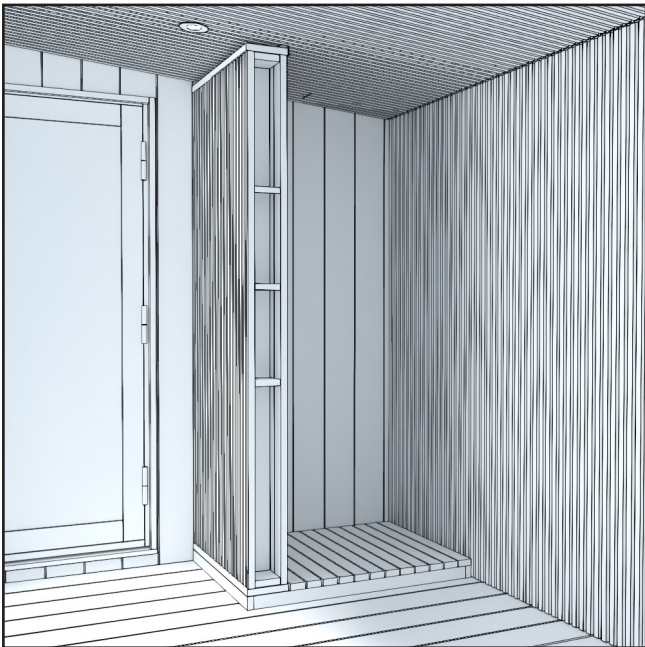

Plaats de buitendouche tegen de verbindingsplaat en de achterwand van het terras. Maak de verbindingsplaat met schroeven vast aan de buitendouche.

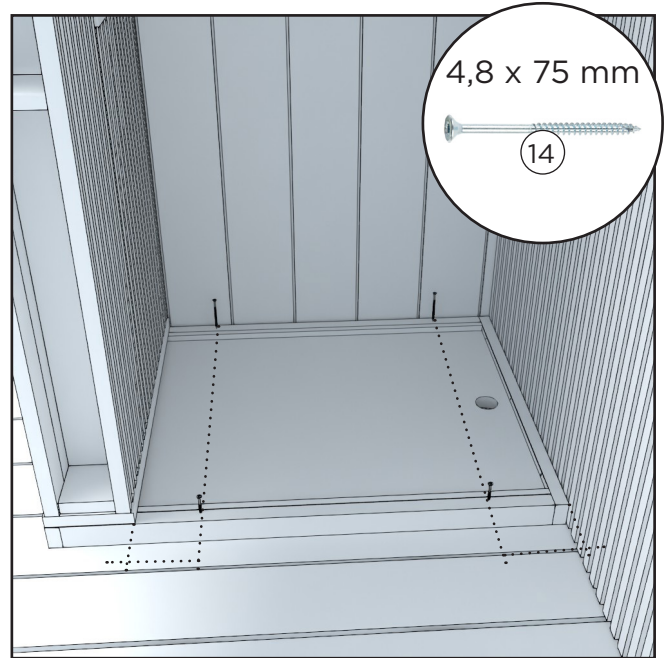
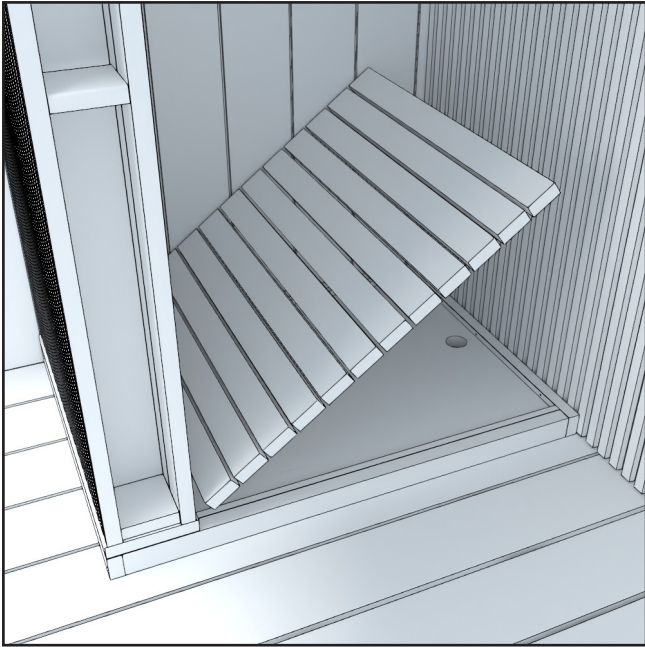

Verwijder het rooster en schroef de basis op het terrasdek. Plaats het rooster terug op z'n plek.

ANDERE MODELLEN VAST- MAKEN

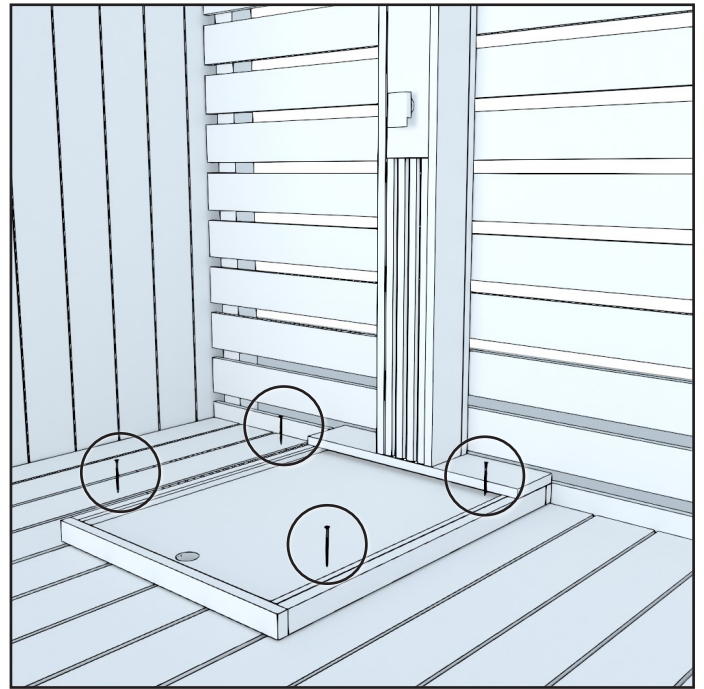
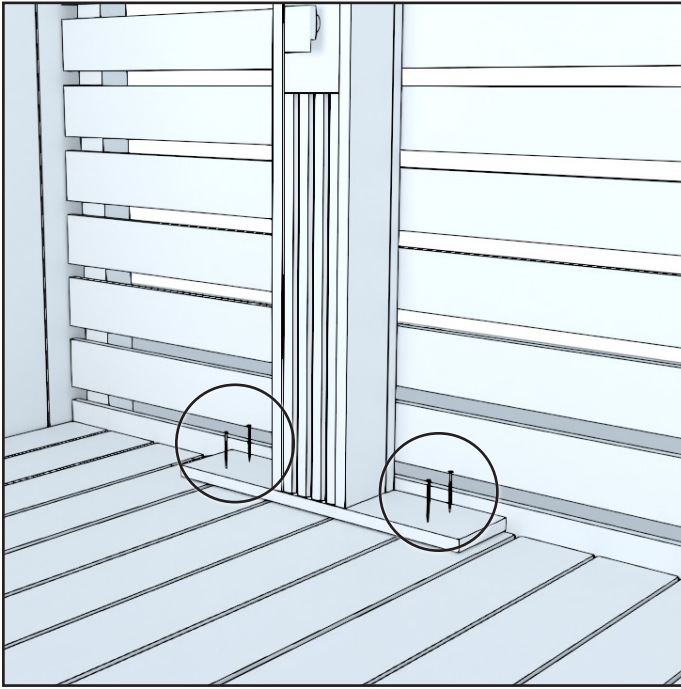

Voor buitendouches van het pilaarmodel maakt u de voet van de buitendouche met vier schroeven vast aan het onderliggende materiaal.

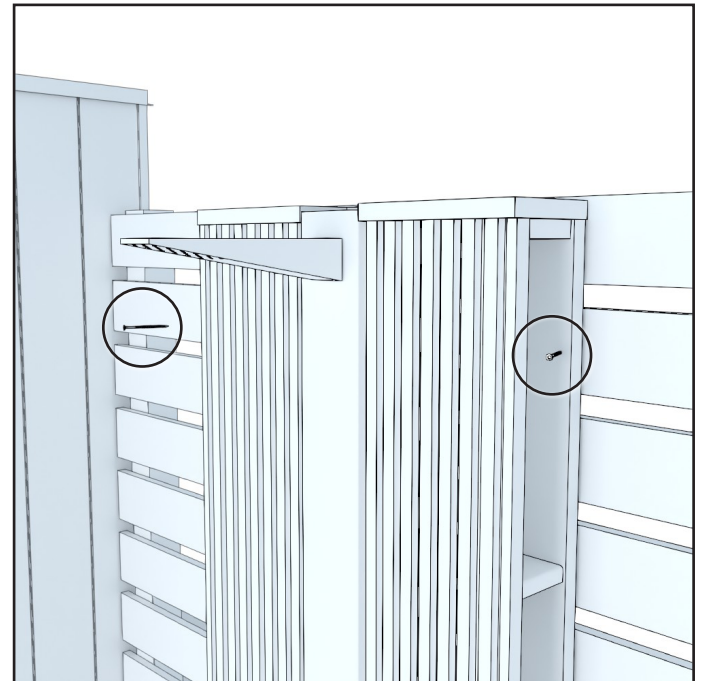
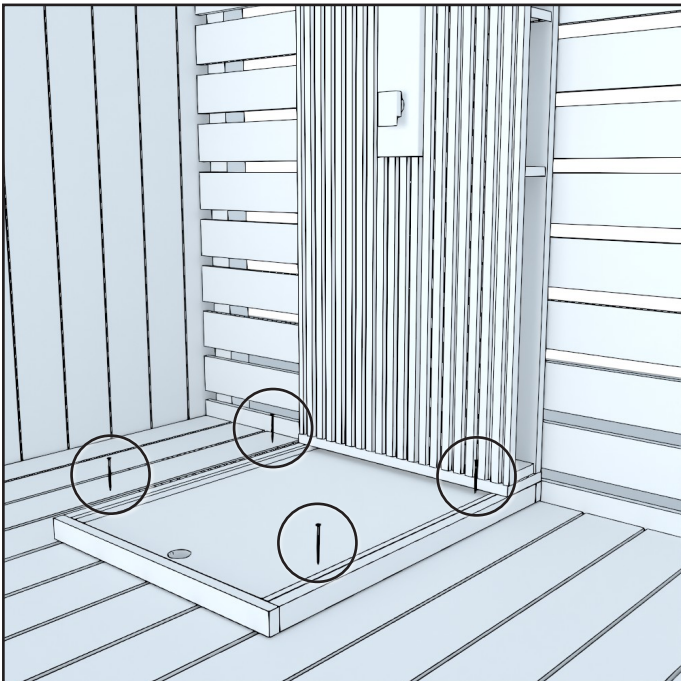

Voor een buitendouche met een wand maakt u de voet eerst met vier schroeven vast aan het onderliggende materiaal. Vervolgens bevestigt u de bovenkant van de muur aan beide zijden met schroeven vast aan het tegenoverliggende materiaal.

AANSLUITING WATERTOEOVOER

De douche is uitgerust met voormonteerde aansluitingen, die zowel op koud- als warmwaterleidingen kunnen worden aangesloten, of op een tuinslang. Het vloerrooster van de douche kan verwijderd worden.

VERBINDING MET DE TUINSLANG

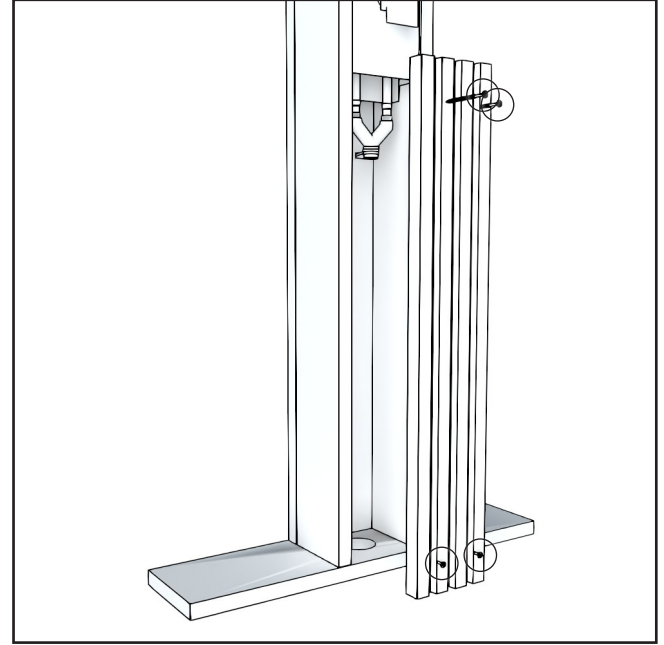

1. De waterinlaataansluitingen bevinden zich onder de voorpanelen. Verwijder de panelen.

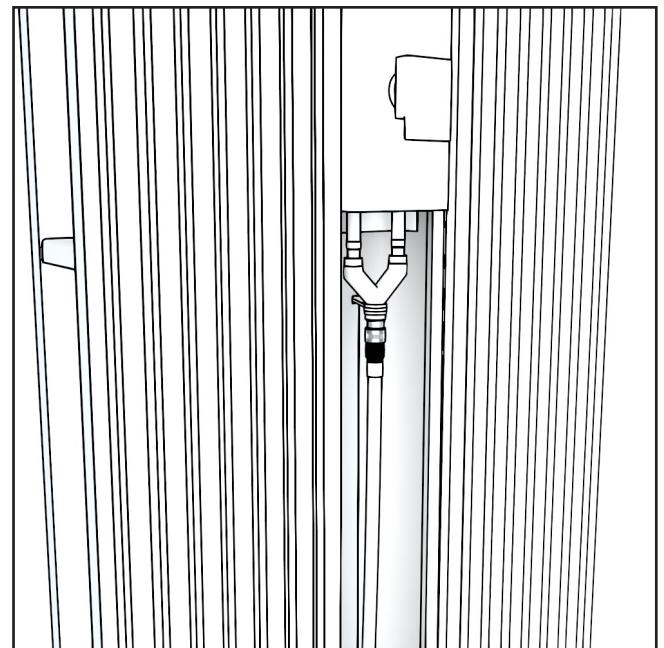

2. Steek de tuinslang door het gat aan de onderkant van de buitendouche en in de muur en sluit deze vervolgens aan op de douche.

Nadat u de slang hebt aangesloten, maakt u beide panelen opnieuw vast.

VERBINDING MET HET WARME EN KOUDE WATER

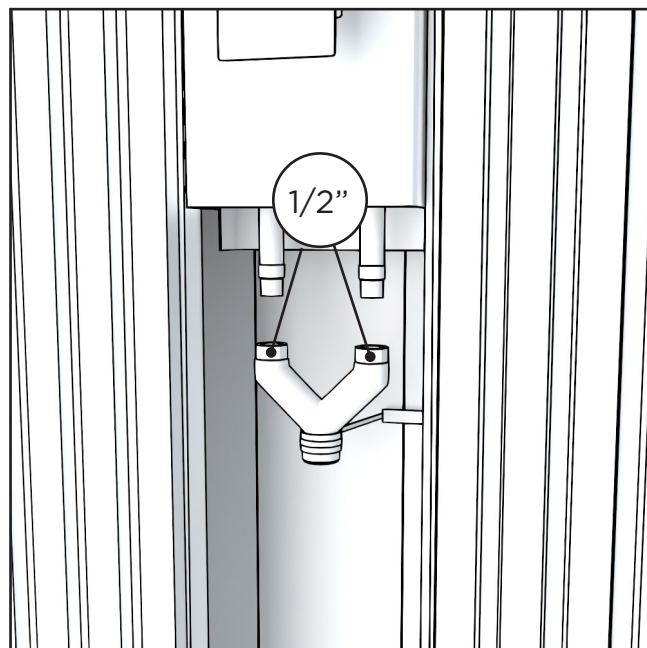
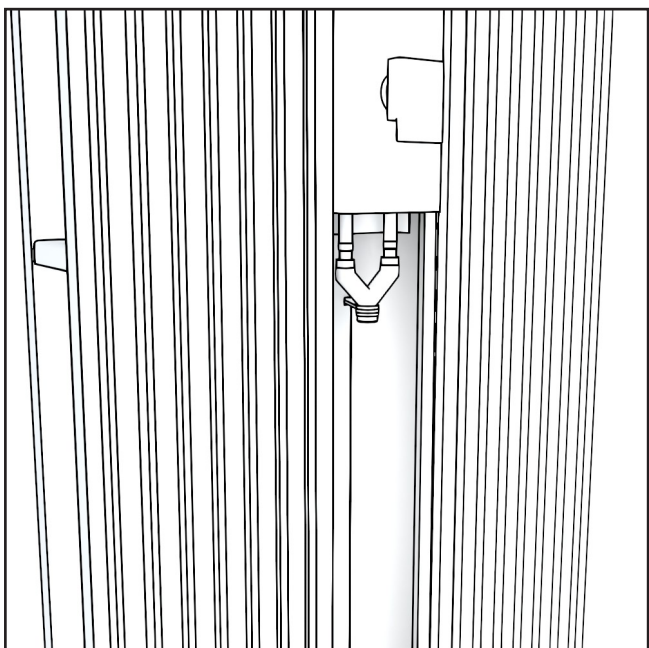

1. Verwijder de messing pijpsplitter door de moeren tegen de klok in te draaien en de beugel los te maken van de muur.

Quick
coupling
nipple
1/2" (15)

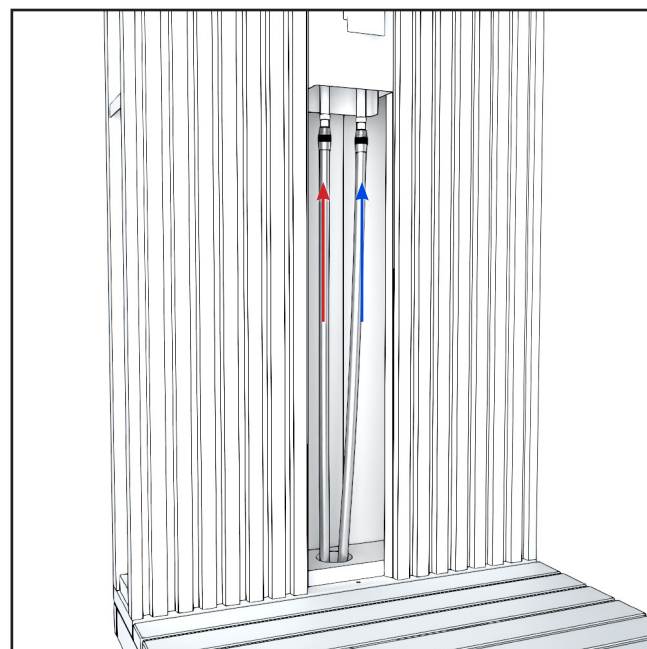
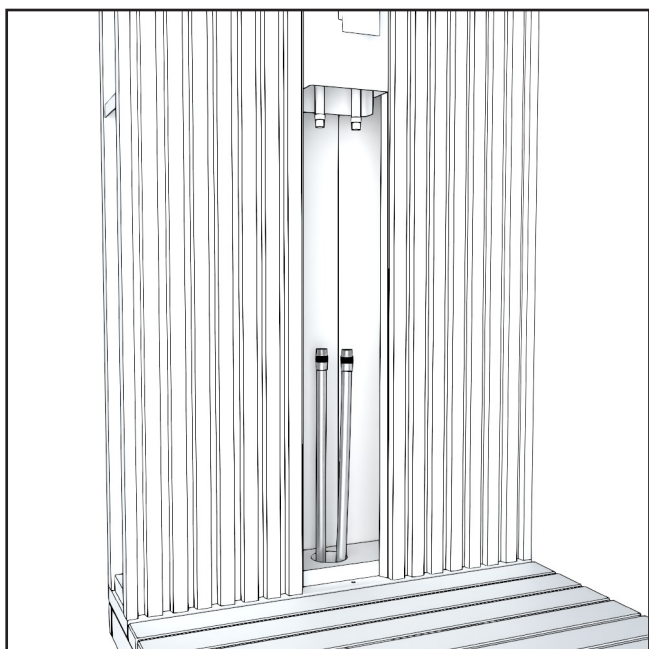

2. Steek de tuinslang/buizen in de muur door het gat dat u in het terras hebt geboord en het gat onder de buitendouche. Bevestig warm water aan de linkerkant en koud water aan de rechterkant.

Wanneer de slangen/leidingen zijn aangesloten, schroeft u de twee panelen opnieuw vast.

DE WATERAFVOER AANSLUITEN

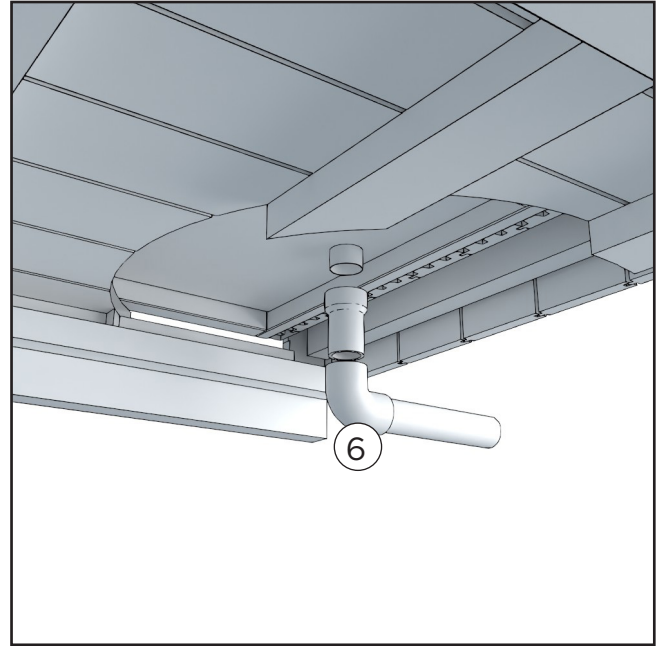
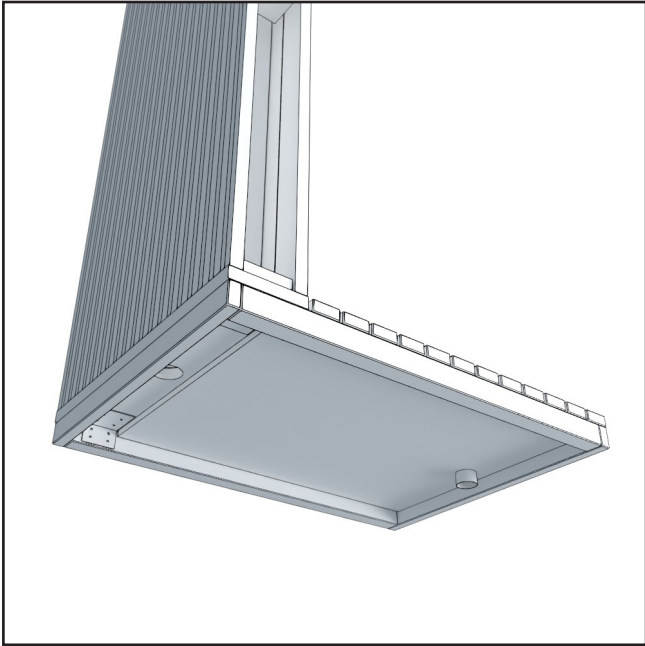

De basis heeft een voorgesneden afvalwaterafvoer van 50 mm. Bij de installatie van het Kirami FinVision® -terras verbindt u de delen van de pijp in de volgorde zoals aangegeven op de afbeelding om de afvoer van de buitendouche naar de achterkant van de module te leiden.

BEVESTIGING VAN DE PLANKEN

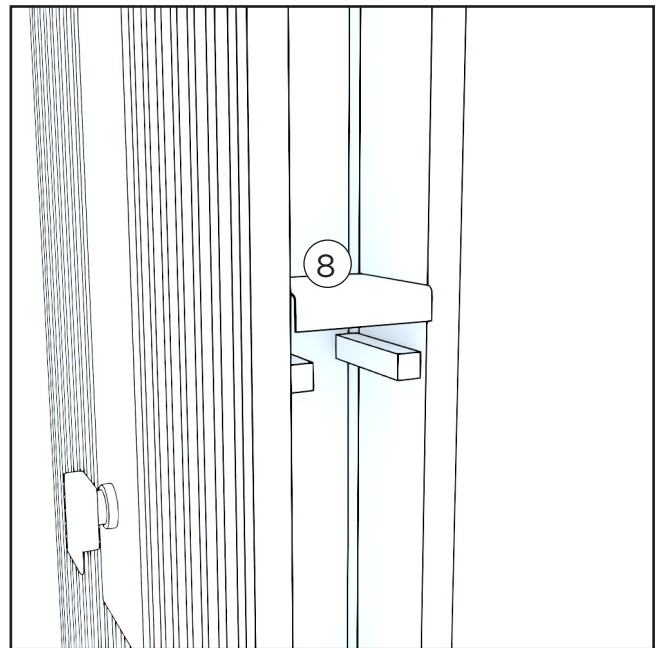
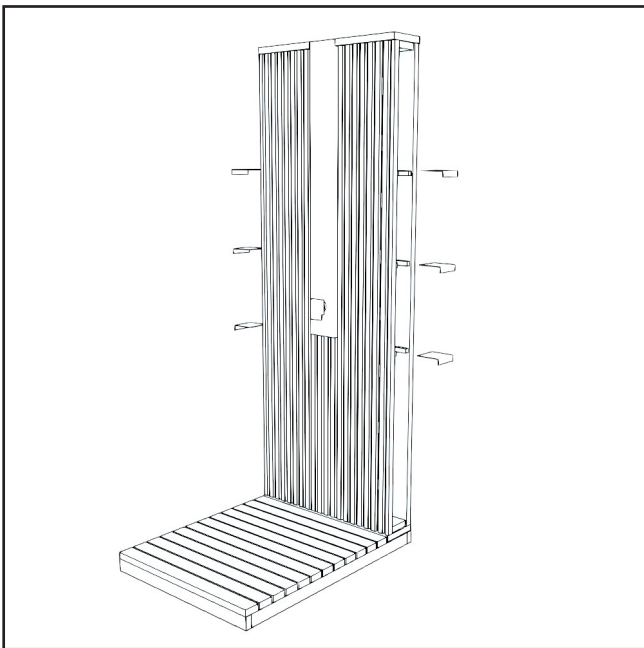

In buitendouches met een douchewand bevinden zich aan de zijkanten plankbeugels. Plaats de planken op de beugels.

GARANTIE

We bieden 24 maanden garantie op het materiaal en op productiegebreken van de sauna.

De garantie is geldig indien de gebruiker de gebruikshandleiding goed heeft gelezen en goed naleeft.

BELANGRIJK! Voor producten die voor commerciële doeleinden worden gebruikt, geldt bij wijze van uitzondering op bovenstaande zaken een garantieperiode van zes maanden.

- De garantie dekt geen eventuele defecten die typisch zijn voor hout. Bijvoorbeeld kleurveranderingen, veranderende vochtigheidsgraden, scheuvorming en gelijkaardige problemen.
- De garantie dekt geen slijtage als gevolg van normaal gebruik.
- De garantie dekt geen schade als gevolg van bijvoorbeeld fouten door de gebruiker.
- De garantie dekt ook geen vorstschade, aangezien deze bij correct gebruik vermeden kan worden.
- De garantie dekt geen corrosie als gevolg van het gebruik van de verkeerde schoonmaakmiddelen.
- De garantie dekt geen indirecte kosten zoals de aanleg of afbraak van een terras.
- Neem bij problemen met de garantie onmiddellijk contact op met de verkoper. De garantie vervalt indien u het product zelf probeert te herstellen.

NA DE LEVENSDUUR VAN HET PRODUCT

De metalen onderdelen van het product moeten naar de metaalcontainer, terwijl de houten onderdelen verbrand kunnen worden en het glas naar een glasrecyclingpunt kan worden gebracht. De andere onderdelen moeten bij het gemengd afval. In Finland kan gebruikte ledverlichting gratis worden teruggebracht naar winkels met lampen in hun productaanbod, zonder dat u verplicht bent om een nieuw product te kopen. U kunt ze ook steeds naar een containerpark of milieupark brengen.

Kirami FinVision® -outdoor shower XL Misty



Manuela utente

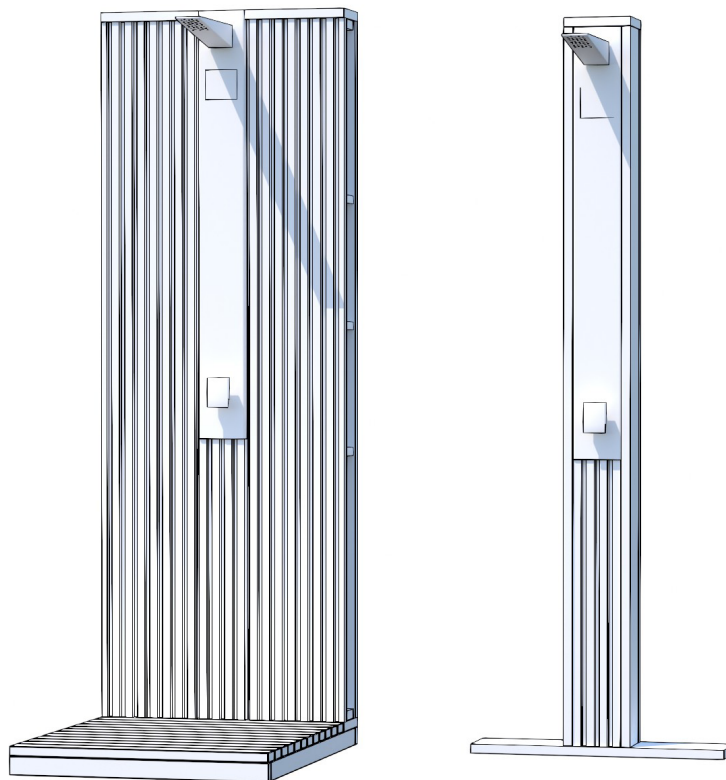

Controllare subito il contenuto del pacco!
Studiare attentamente le istruzioni e conservarle come
futuro riferimento.

INFORMAZIONI GENERALI

Quando si ordina la doccia insieme alla terrazza, il modulo della doccia per esterno è pre-assemblato a quello della terrazza. È possibile anche installare le pareti in un secondo momento, in tal caso la doccia viene fornita in pezzi.

La doccia è dotata di raccordi pre-assemblati, che possono essere collegati ai tubi dell'acqua calda e dell'acqua fredda o, in alternativa, ai tubi da giardino.

La griglia del pavimento della doccia dotata di piattaforma è rimovibile. Sotto la griglia si trova una vasca in lamiera zincata che convoglia l'acqua di lavaggio verso il tubo di scarico.

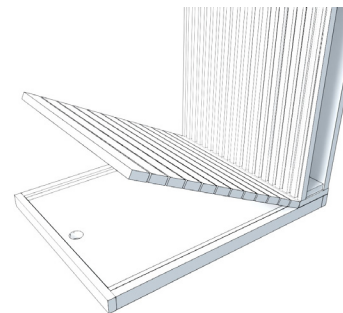

VERIFICA DELLA SPEDIZIONE

Si consiglia di verificare sempre che la merce ricevuta sia intatta prima di firmare la bolta di accompagnamento. Se in un secondo momento ci si accorge che manca qualcosa, contattare la società che ha effettuato la consegna del prodotto.



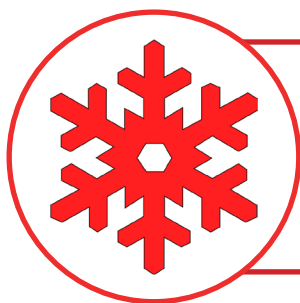







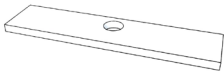

Se la doccia per esterno è stata ordinata contemporaneamente ad altri moduli, è possibile accedere alle sezioni "COLLEGAMENTO PER L'ACQUA IN INGRESSO" e "COLLEGAMENTO PER LO SCARICO DELL'ACQUA".

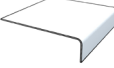
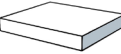

ATTENZIONE! In inverno, la doccia per esterno deve essere svuotata dall'acqua per evitare danni provocati dal gelo.

Aprire il rubinetto e immettere aria compressa nel sistema.

ELENCO DEI COMPONENTI

Nro	Kuva	Nimi	Pilari (Ilman alustaa)	Pilari (Alustalla)	Suihkuseinä (Terassimalli)	Suihkuseinä (Ulkomalli)
1.		Base			1	1
2.		Tavola di base per pilastro	1	1		
3.		Parete			1	1
4.		Colonna	1	1		
5.		Soffione (inclu- de rondella e dado)	1	1	1	1
6.		Tubo di scarico		1	1	1
7.		Piastra di col- legamento al soffitto			1	
8.		Mensola			6	6
9.		Protezione - Pi- lastro	1	1		
10.		Piastra di pro- tezione				1
11.		Vite 5x35 mm			8	
12.		Vite 4,2 x 19 mm		10	10	10
13.		Vite 4,8x25				4
14.		Vite 4,8 x 75 mm	12	12	4	6

INSTALLAZIONE

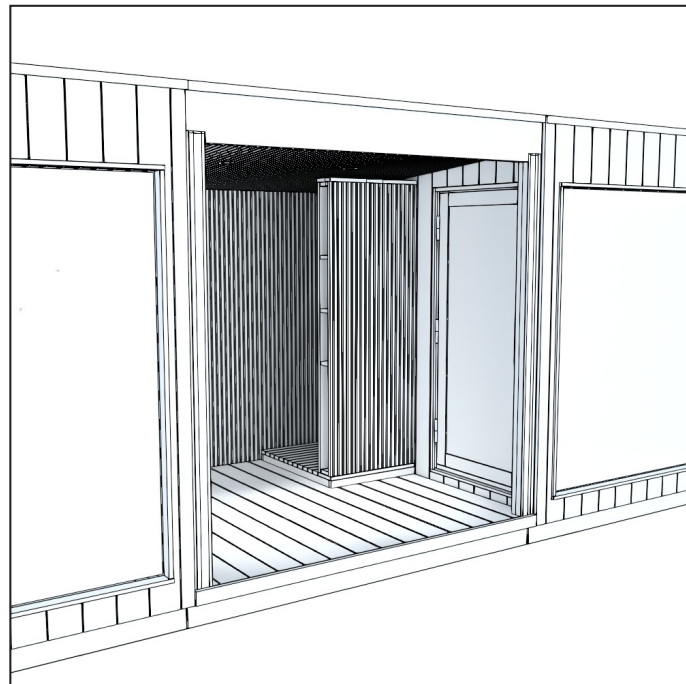
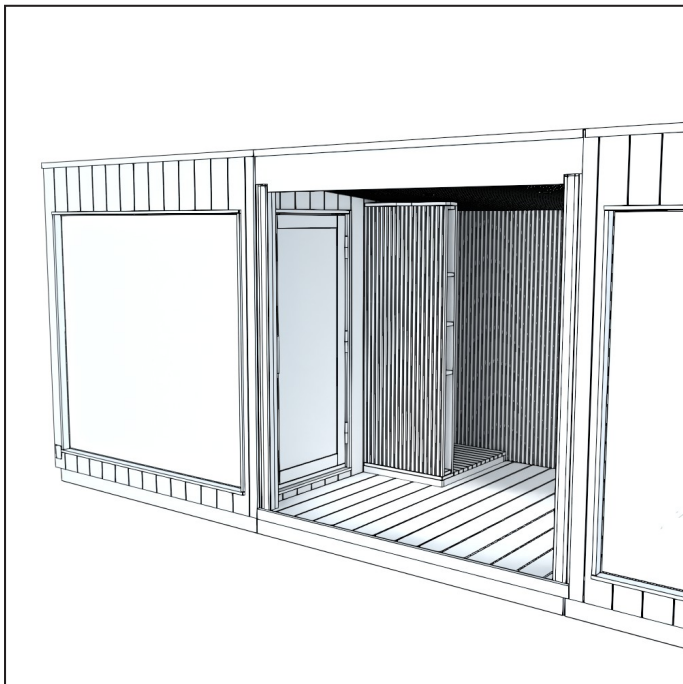

La doccia per esterno Kirami FinVision® Misty (modello per terrazza) viene sempre installata sulla terrazza Kirami FinVision®, sul bordo destro o sinistro, in modo che un lato della doccia si trovi a ridosso di un altro modulo.

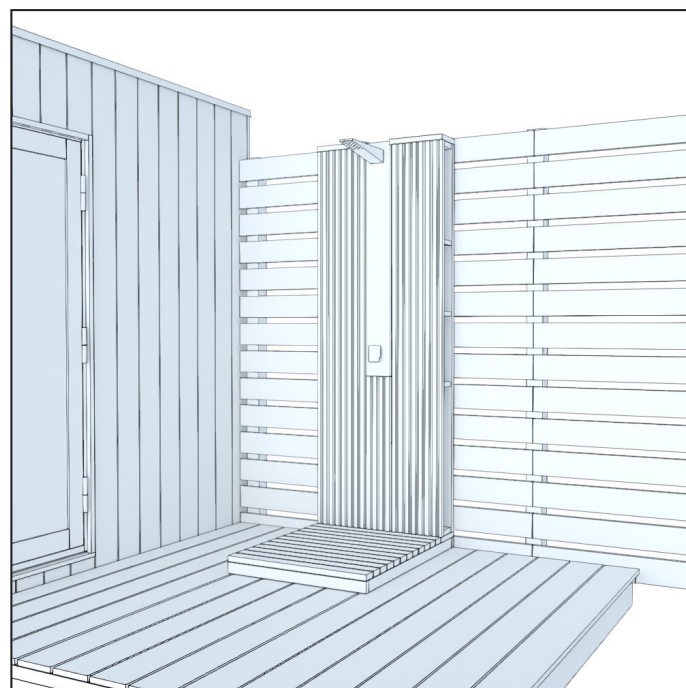
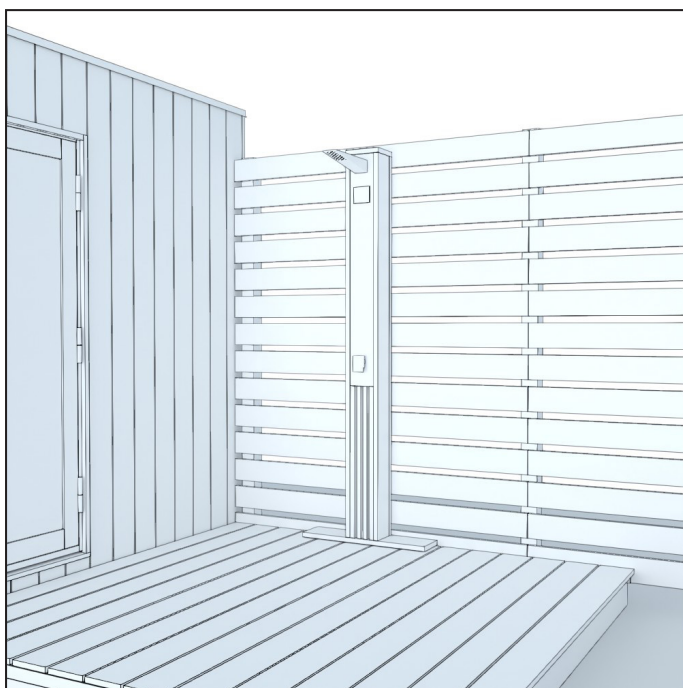

Le docce per esterno Kirami FinVision® (modello fuori terrazza) e i modelli a colonna possono essere installati su qualsiasi superficie piana, come una terrazza esterna o sul tetto, vicino a una tinozza, una piscina o una sauna.

Si consiglia sempre di installare le docce per esterno a ridosso di un muro o di un'altra struttura stabile.

ASSEMBLAGGIO

Colonna

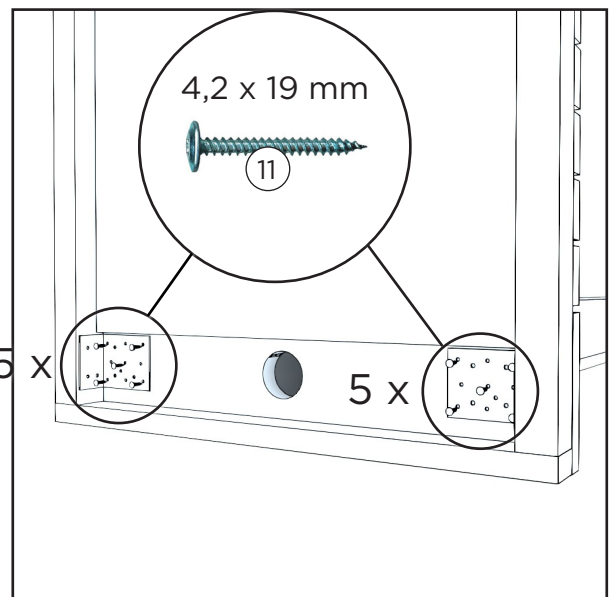
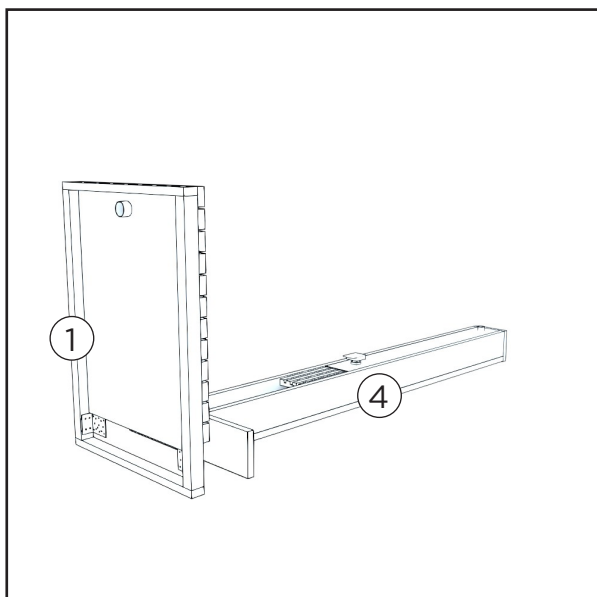
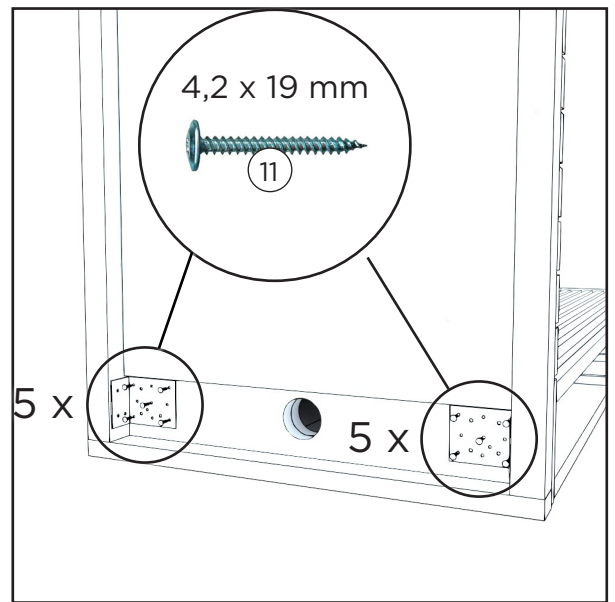
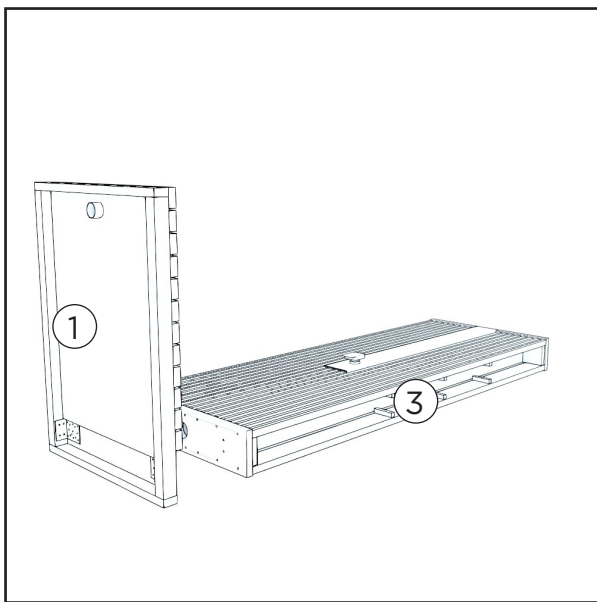
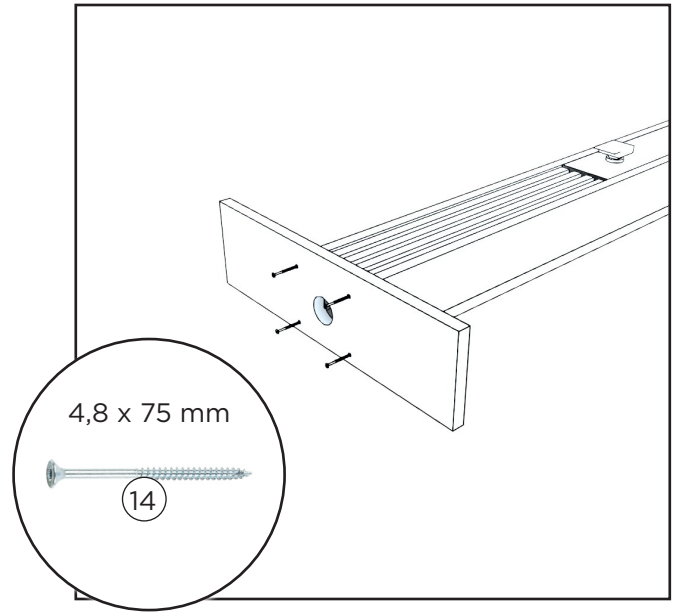
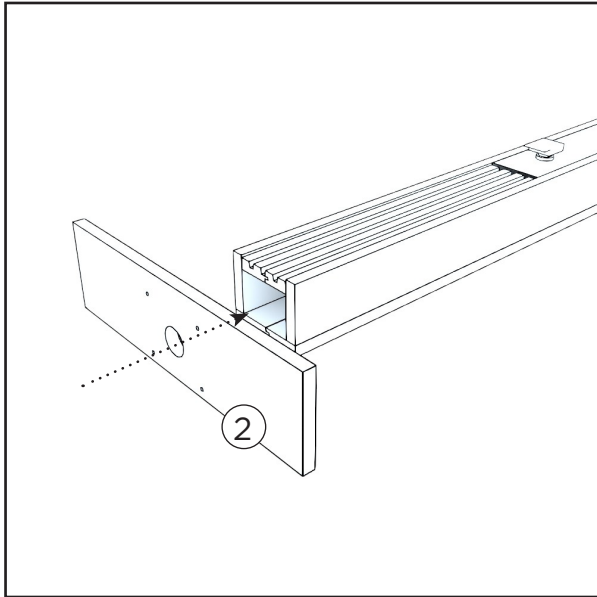

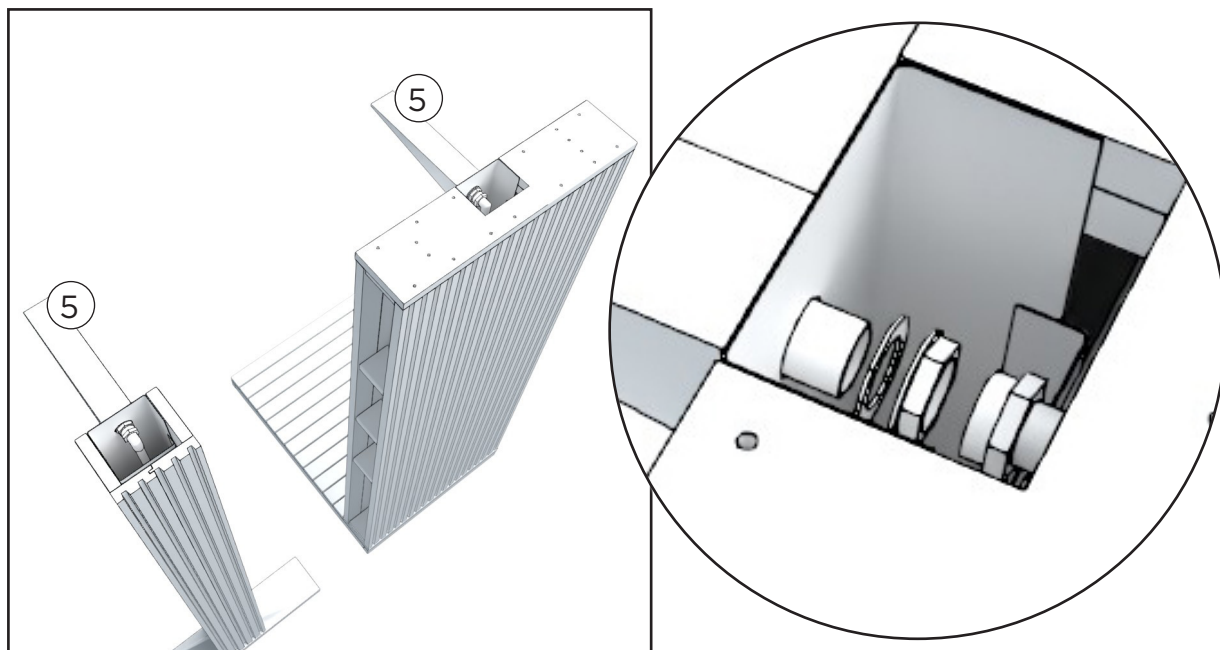

Fissare il soffione alla piastra in acciaio inox utilizzando un dado in ottone; è necessario inserire una rondella tra la piastra in acciaio inox e il dado in ottone. Rimuovere il nastro dal gomito all'interno della doccia e collegarlo al soffione.

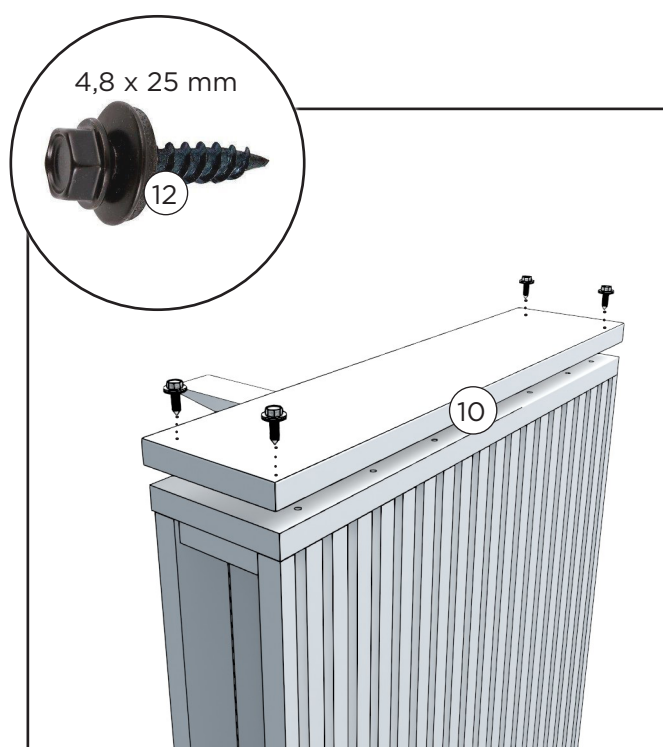
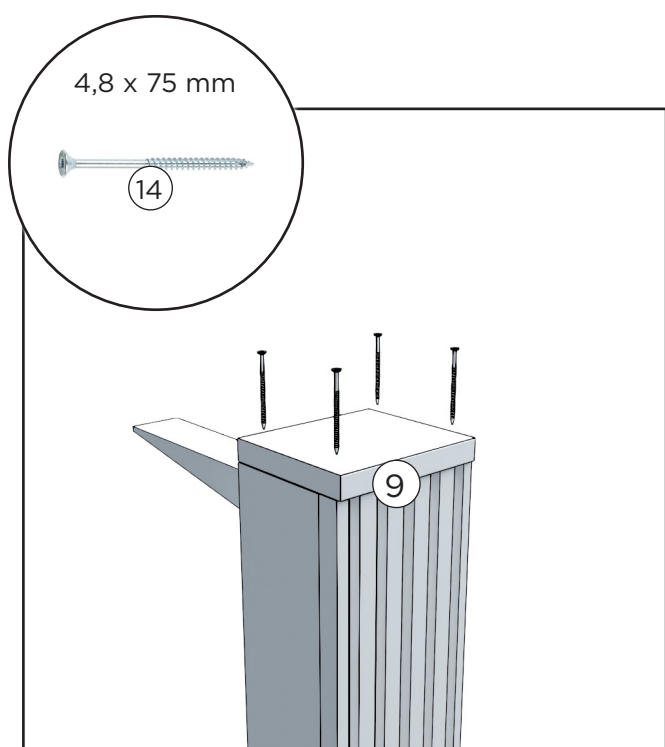

Modello a colonna: Fissare l'estremità alla doccia per esterno con quattro viti.

Doccia per esterno (modello per esterno): Fissare la piastra di protezione all'estremità della doccia per esterno con quattro viti.

Nota: Per il modello di doccia da terrazza non è prevista nessuna piastra di protezione.

INSTALLAZIONE DELLA DOCCIA PER ESTERNO IN TERRAZZA

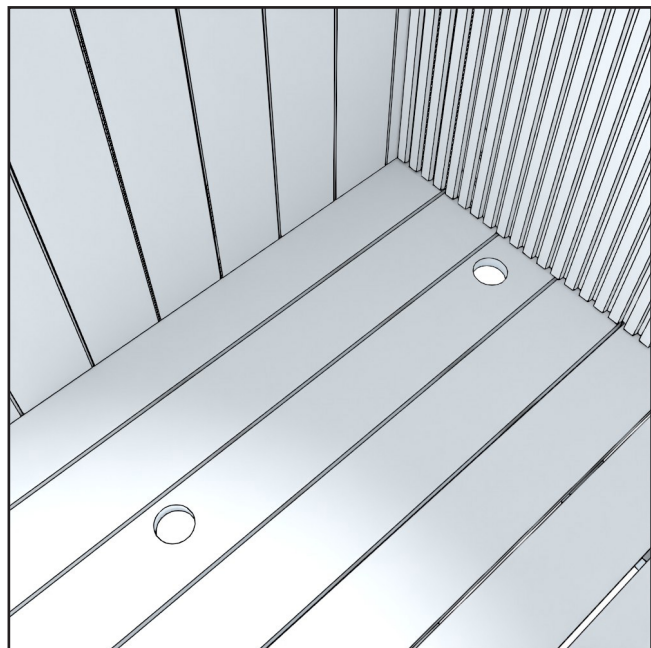
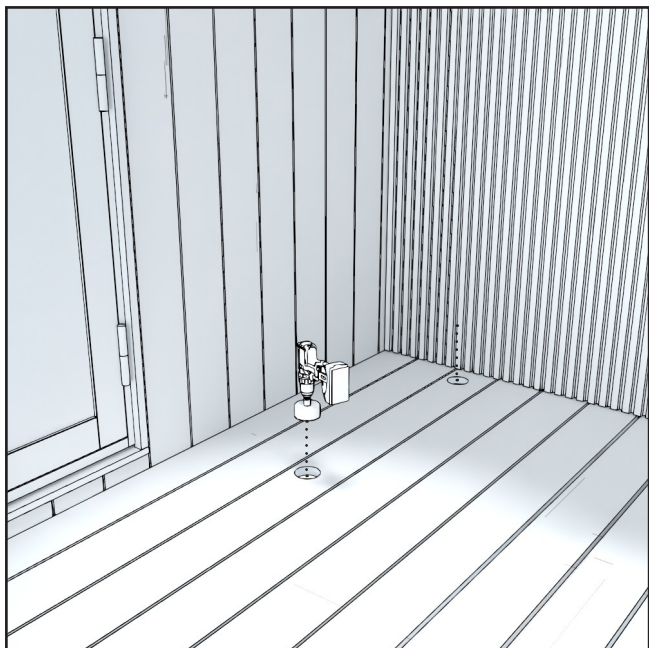

Nel caso in cui la doccia per esterno Kirami FinVision® - Misty venga ordinata successivamente, è necessario praticare dei fori nel modulo della terrazza per l'ingresso e l'uscita dell'acqua. Il diametro del foro da praticare nel modulo della terrazza deve essere di almeno 73 mm.

Dimensioni per l'installazione a sinistra:

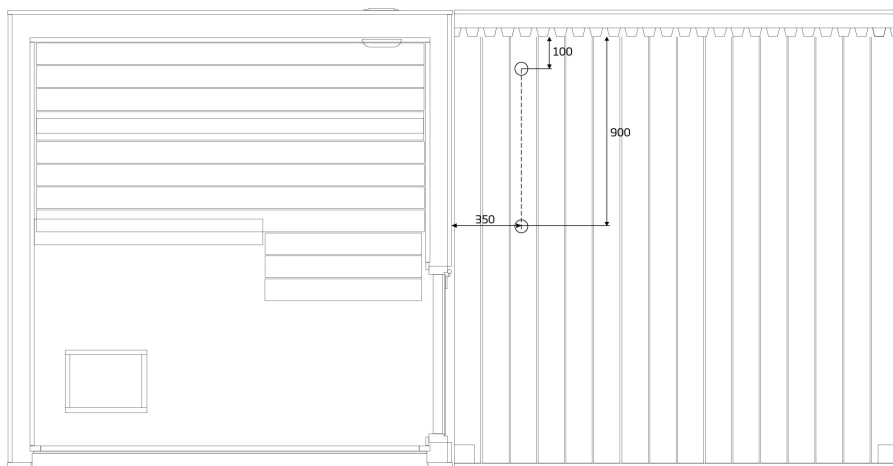

Dimensioni per l'installazione a destra:

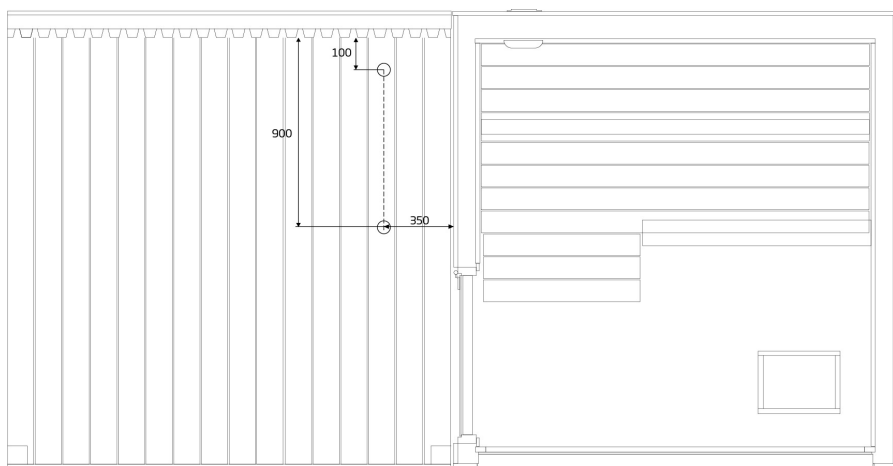

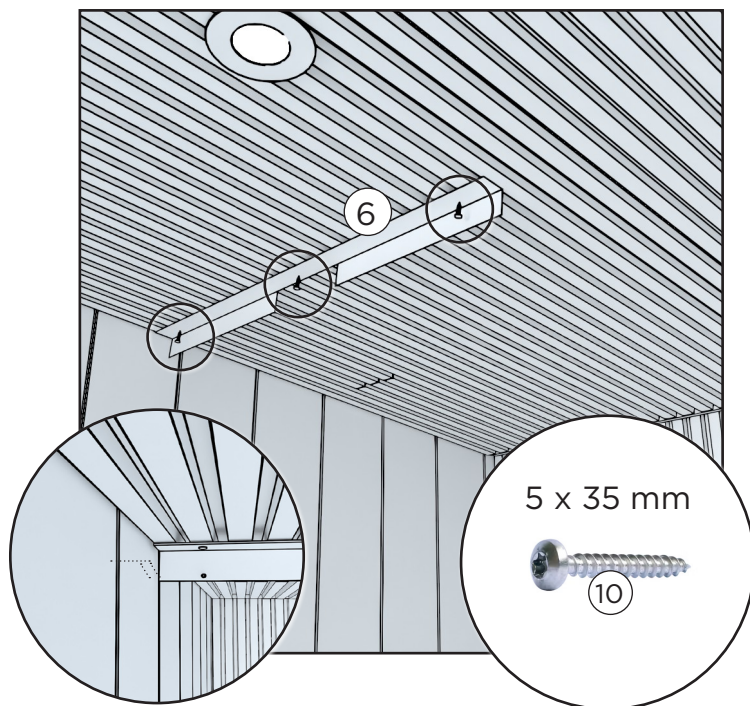
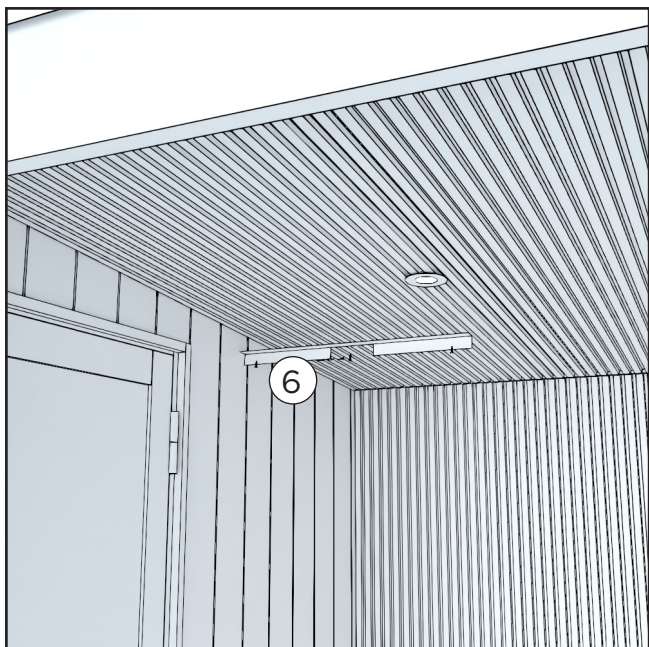

Fissare la piastra di collegamento tra la doccia per esterno e il tetto al soffitto della terrazza, posizionandola a 830 mm dalla parete posteriore e a 3-5 mm dalla parete laterale.

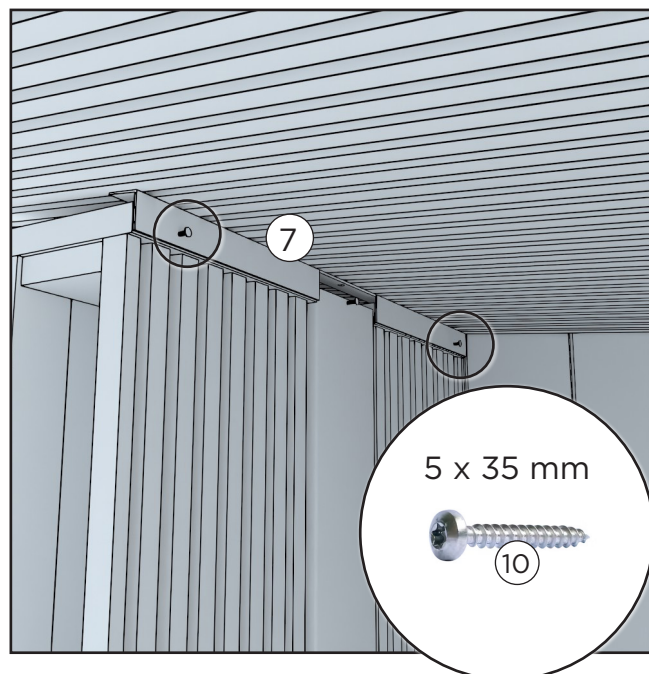
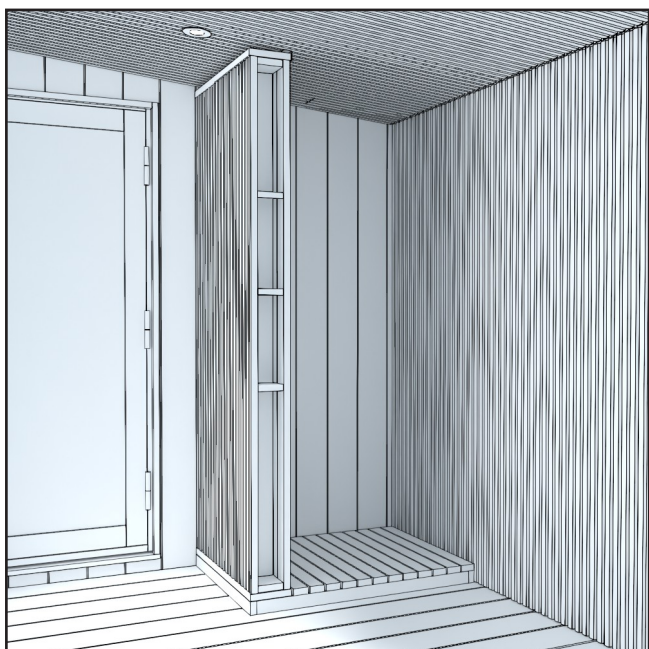

Posizionare la doccia per esterno contro la piastra di collegamento e la parete posteriore della terrazza. Fissare la piastra di collegamento alla doccia con le viti.

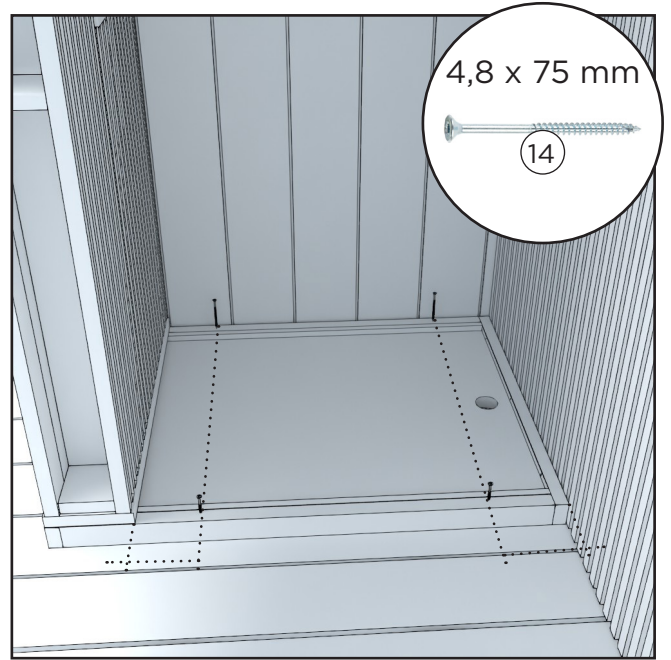
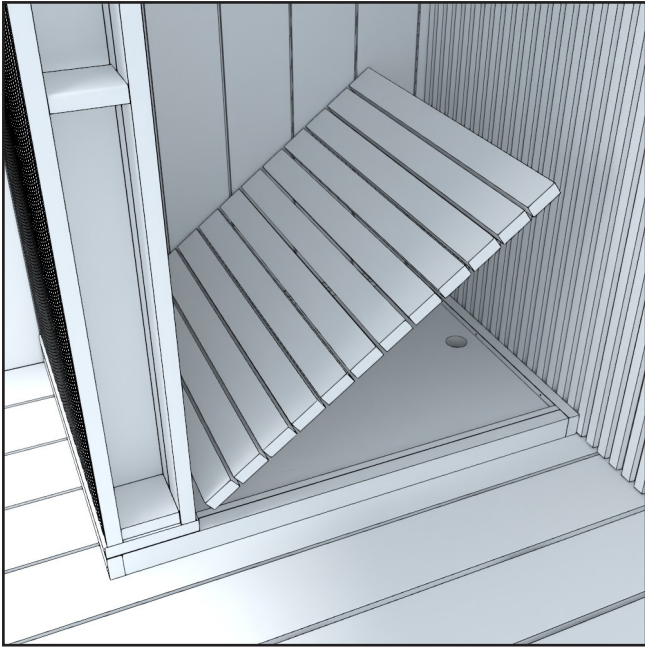

Sollevare la griglia e avvitare la base sulla terrazza. Rimettere in posizione la griglia di base.

INSTALLAZIONE DI ALTRI MODELLI

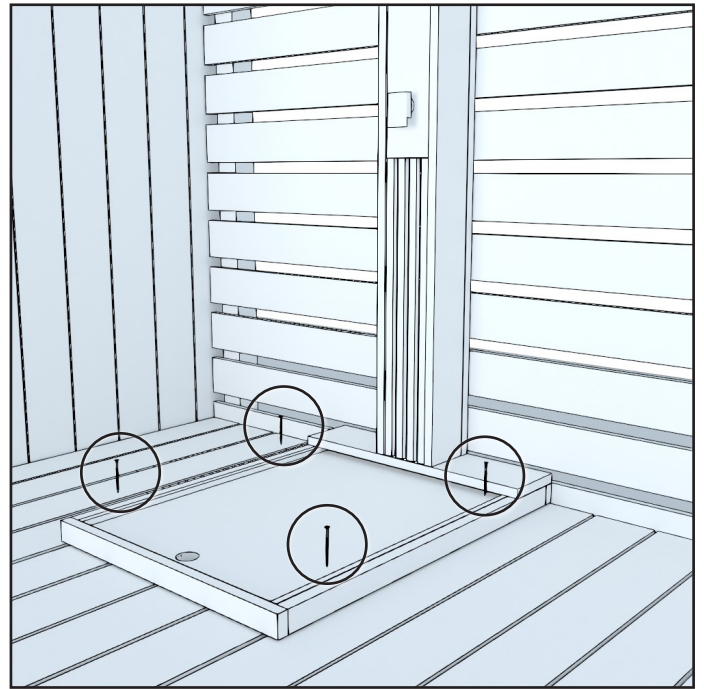
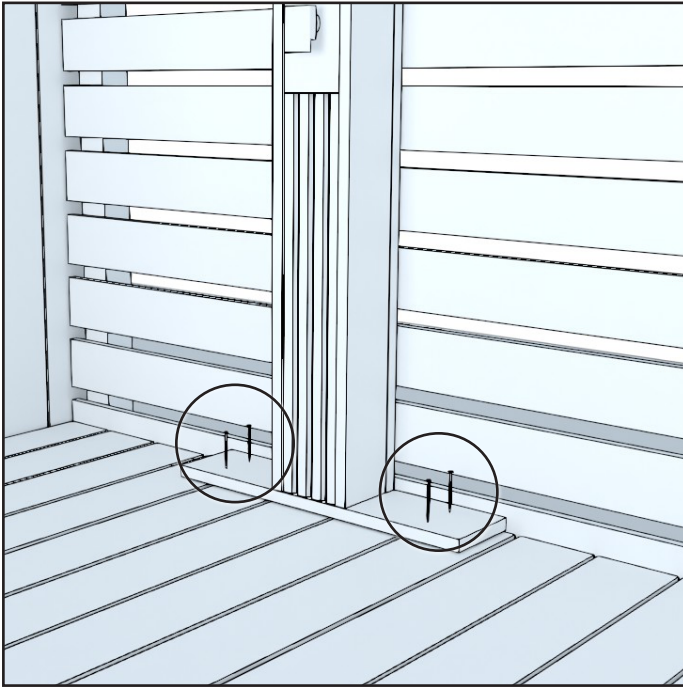

Per le docce a colonna, fissare la base della doccia per esterno alla parte sottostante con quattro viti.

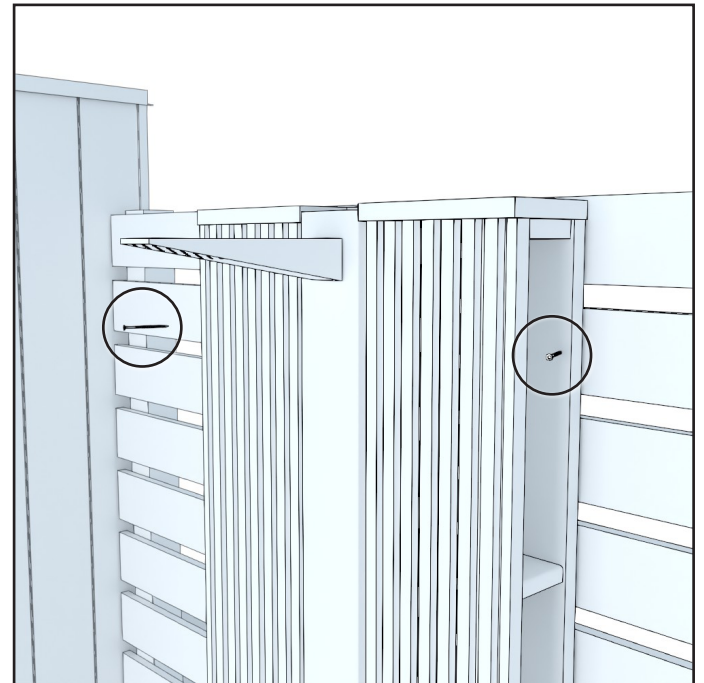
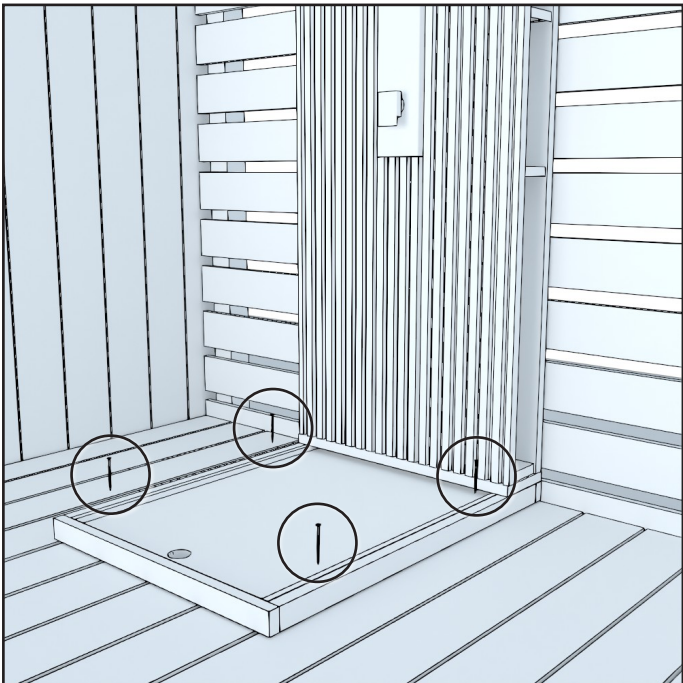

Per le docce con parete, fissare innanzitutto la base alla parte sottostante con quattro viti. Quindi, fissare la parte superiore della parete al materiale opposto su due lati con delle viti.

COLLEGAMENTO PER L'INGRESSO DELL'ACQUA

La doccia è dotata di attacchi preassemblati, che possono essere collegati alle tubature dell'acqua calda e fredda o, in alternativa, a un tubo da giardino.

COLLEGAMENTO CON IL TUBO DA GIARDINO

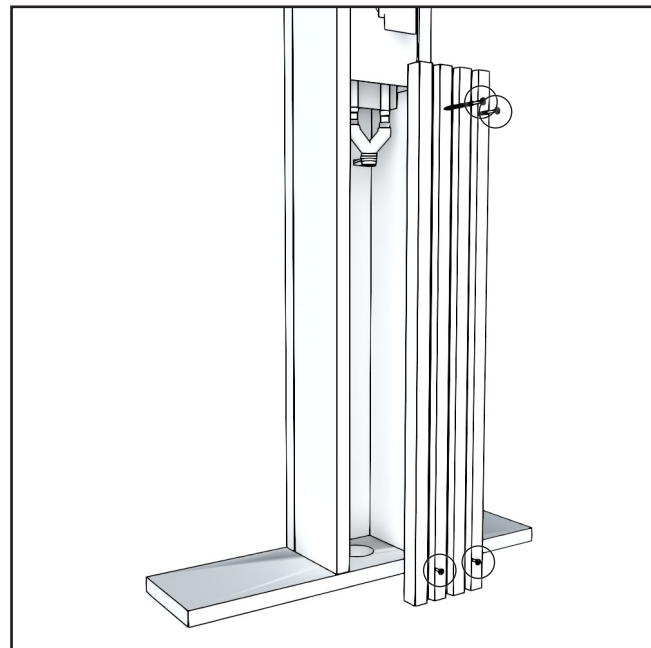
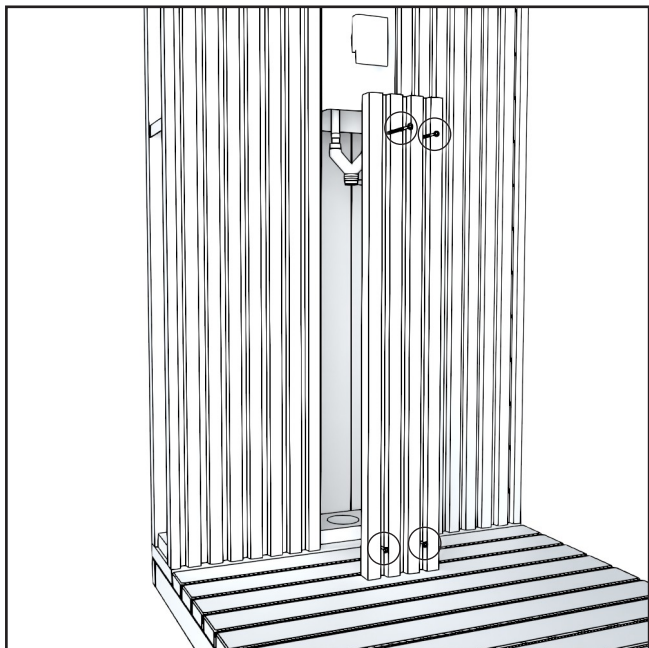

1. I raccordi per l'ingresso dell'acqua si trovano sotto i pannelli frontali. Rimuovere i pannelli.

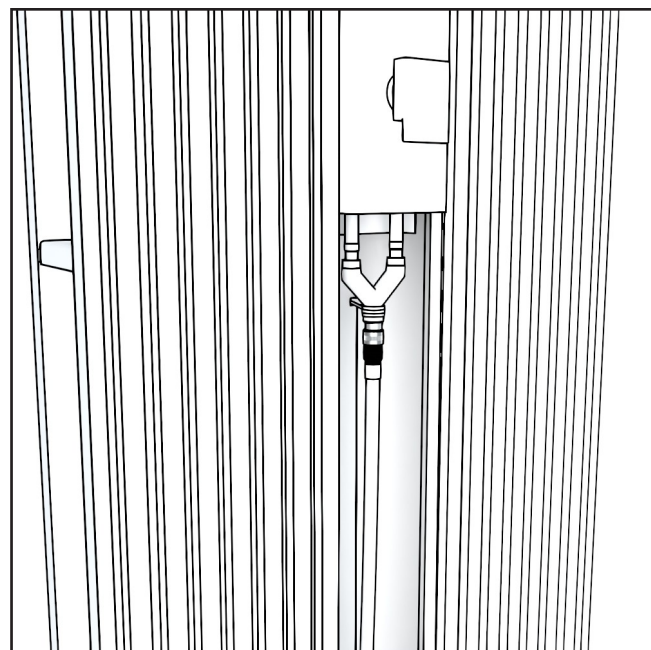

2. Infilare il tubo da giardino attraverso il foro alla base della doccia per esterno e nella parete, quindi collegarlo alla doccia.

Una volta collegato il tubo, rimettere in posizione i due pannelli.

TUBO PER IL COLLEGAMENTO ALL'ACQUA CALDA E FREDDA

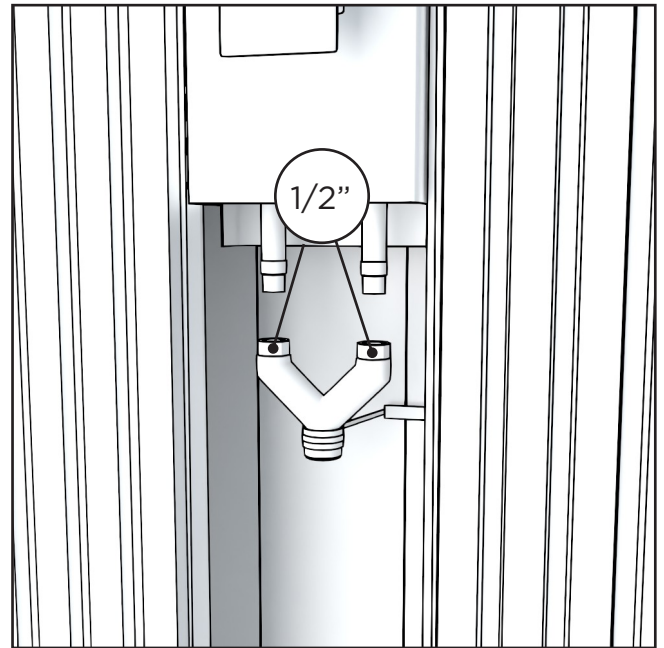
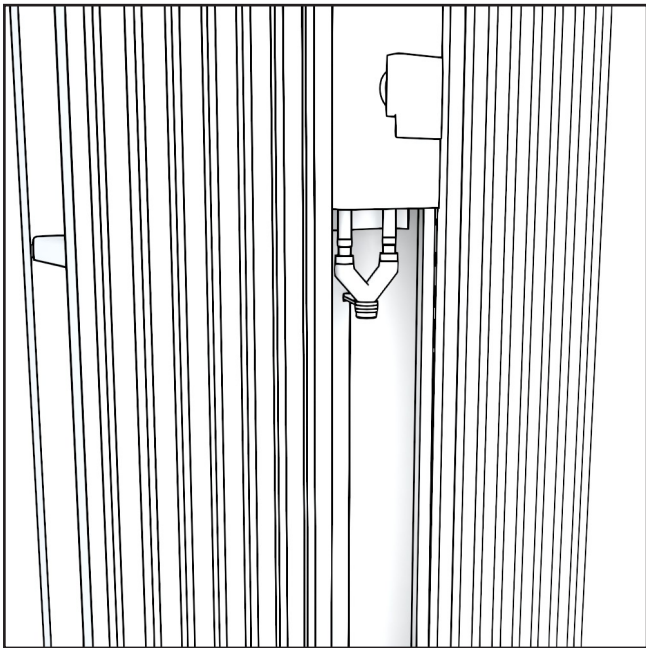

1. Rimuovere lo snodo in ottone ruotando i dadi in senso antiorario e staccando la staffa dalla parete.

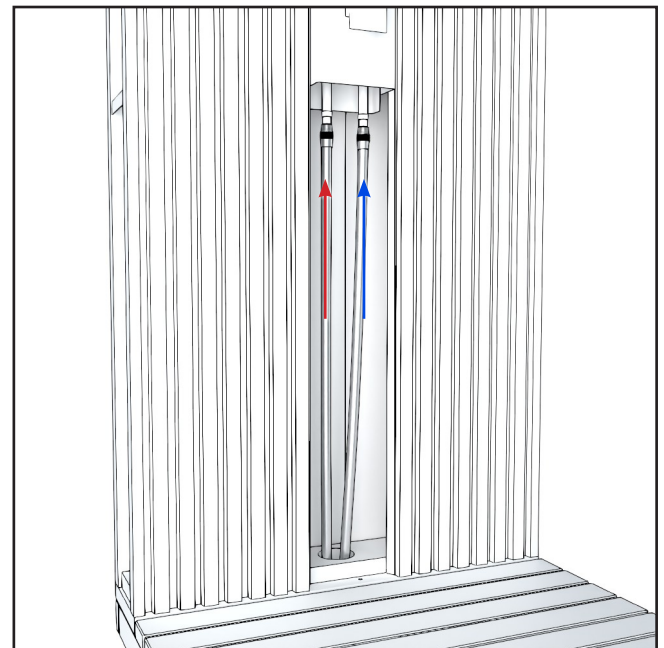
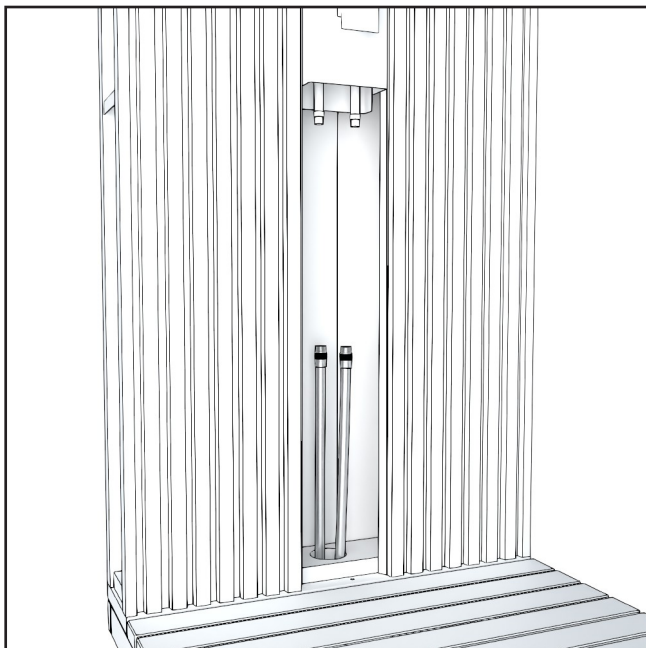

2. Infilare il tubo da giardino nella parete attraverso il foro praticato nella terrazza e il foro alla base della doccia. Collegare l'acqua calda a sinistra e quella fredda a destra.

Una volta collegati i tubi flessibili, riavvitare i due pannelli.

COLLEGAMENTO DELLO SCARICO

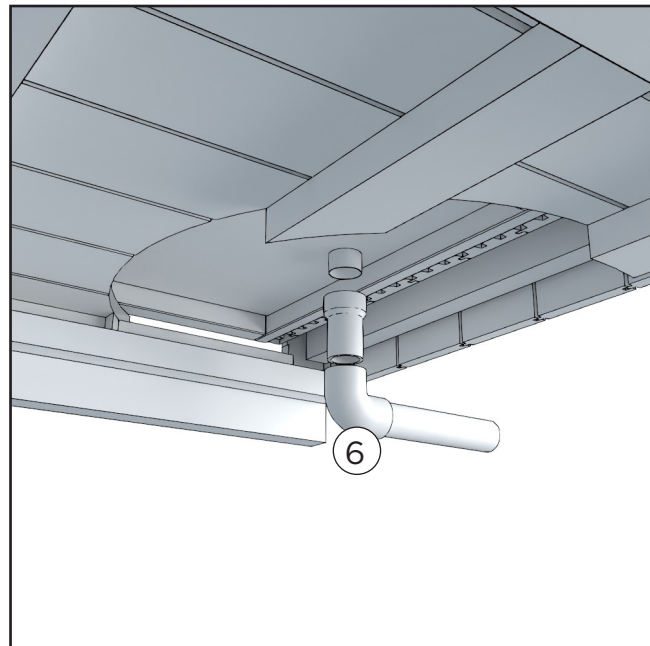
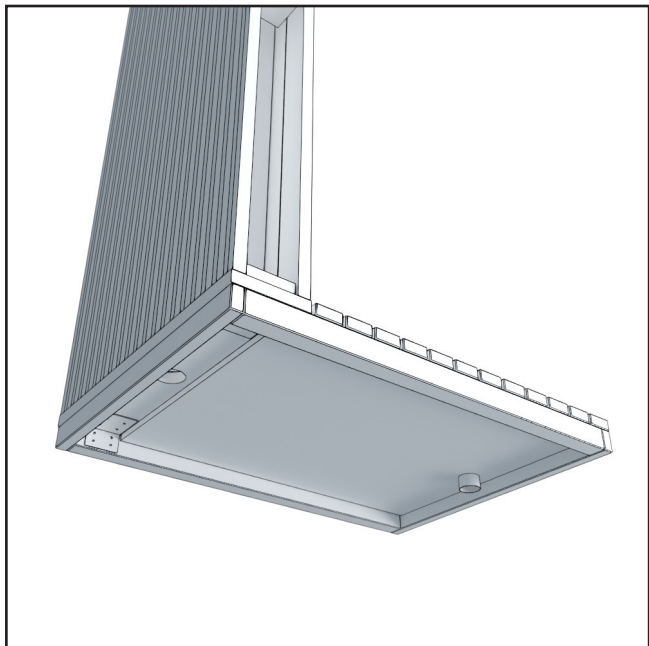

La base è dotata di un tubo di scarico pre-assemblato da 50 mm per il drenaggio delle acque reflue. Al momento dell'installazione della terrazza Kirami FinVision®, collegare le parti di tubo nell'ordine mostrato nell'immagine in modo da far passare lo scarico della doccia sul retro del modulo.

INSTALLAZIONE DELLE MENSOLE

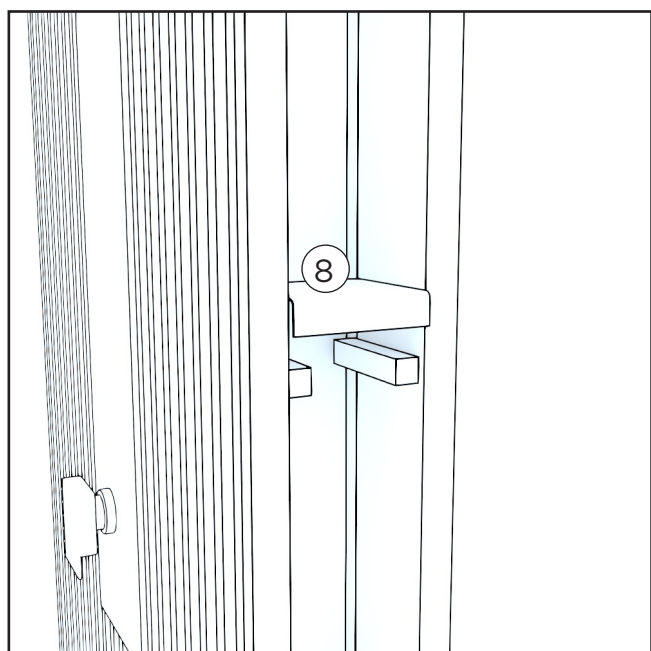
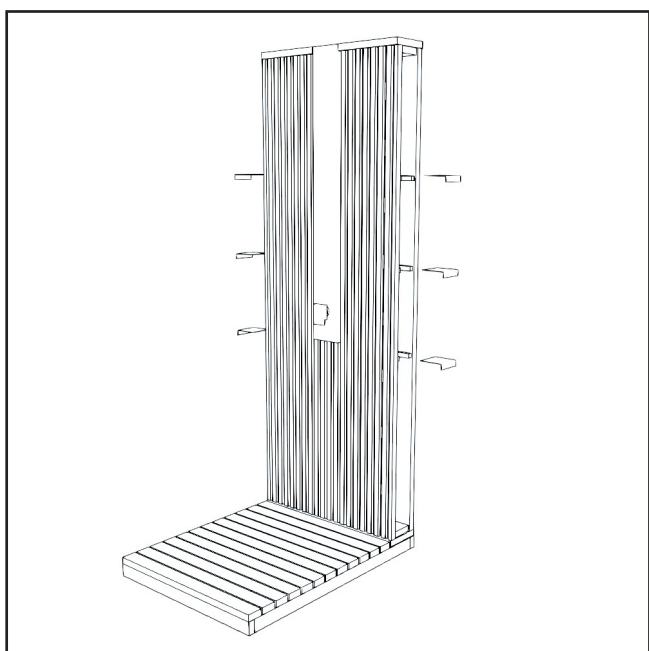

Nelle docce per esterno con parete, i supporti per le mensole si trovano ai lati. Posizionare i ripiani sulle staffe.

GARANZIA

La nostra sauna gode di una garanzia di 24 mesi sui difetti di materiale e di fabbricazione.

La garanzia è valida a condizione che l'utente abbia letto e rispettato le istruzioni per l'uso del prodotto.

NOTA! Fa eccezione il periodo di garanzia di 6 mesi concesso ai prodotti utilizzati per scopi commerciali.

- La garanzia non copre eventuali difetti tipici delle parti in legno che possono verificarsi. Ad esempio, cambiamenti di colore, variazioni di umidità, formazione di crepe e problemi simili.
- La garanzia non copre l'usura dovuta al normale utilizzo.
- La garanzia non copre i danni dovuti, ad esempio, a un errore dell'utente.
- La garanzia non copre nemmeno i danni da gelo, che possono essere evitati con un uso corretto.
- La garanzia non copre la corrosione dovuta all'uso di detergenti sbagliati.
- La garanzia non copre i costi indiretti come ad esempio la demolizione o la costruzione di una terrazza.

Contattare immediatamente il venditore del prodotto in caso di problemi legati alla garanzia. Ogni tentativo di riparare il prodotto da soli invalida la garanzia.

SMALTIMENTO DEL PRODOTTO

Le parti metalliche del prodotto devono essere trasportate in un punto di riciclaggio dei metalli, mentre le parti in legno possono essere bruciate e il vetro può essere portato in un punto di riciclaggio del vetro. Le altre parti devono essere smaltite con i rifiuti misti. In Finlandia, le lampade a LED usate possono essere restituite gratuitamente e senza obbligo di acquisto di un nuovo prodotto nei negozi in cui vengono abitualmente vendute, o in alternativa possono essere portate in un punto di riciclaggio.

Let's sauna.



@ kiramioy
@ harviaglobal

GLOBAL

Kirami Oy
Villiläntie 2
32730 Sastamala
FINLAND
T +358 10 574 2170
info@kirami.fi

GLOBAL

Harvia Finland
Teollisuustie 1-7
40951 Muurame
FINLAND
T +358 207 464 000
harvia@harvia.com